

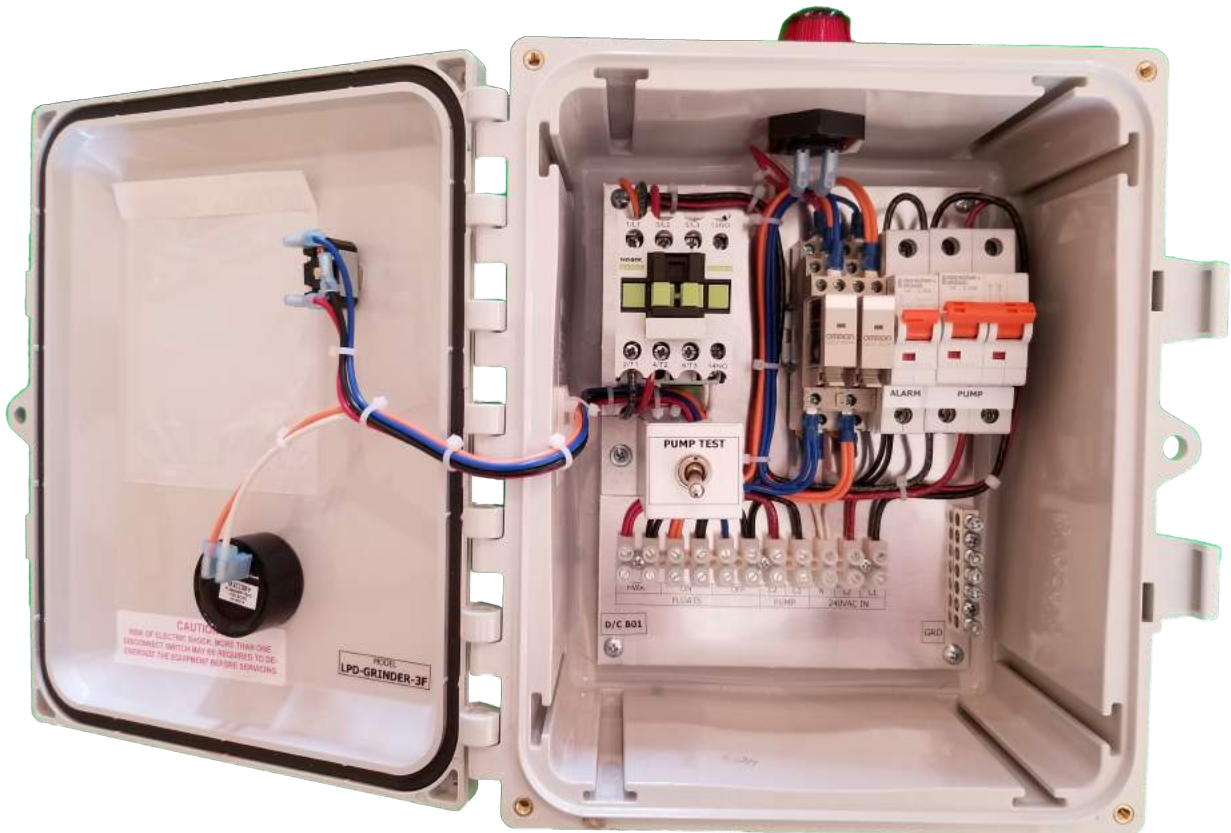

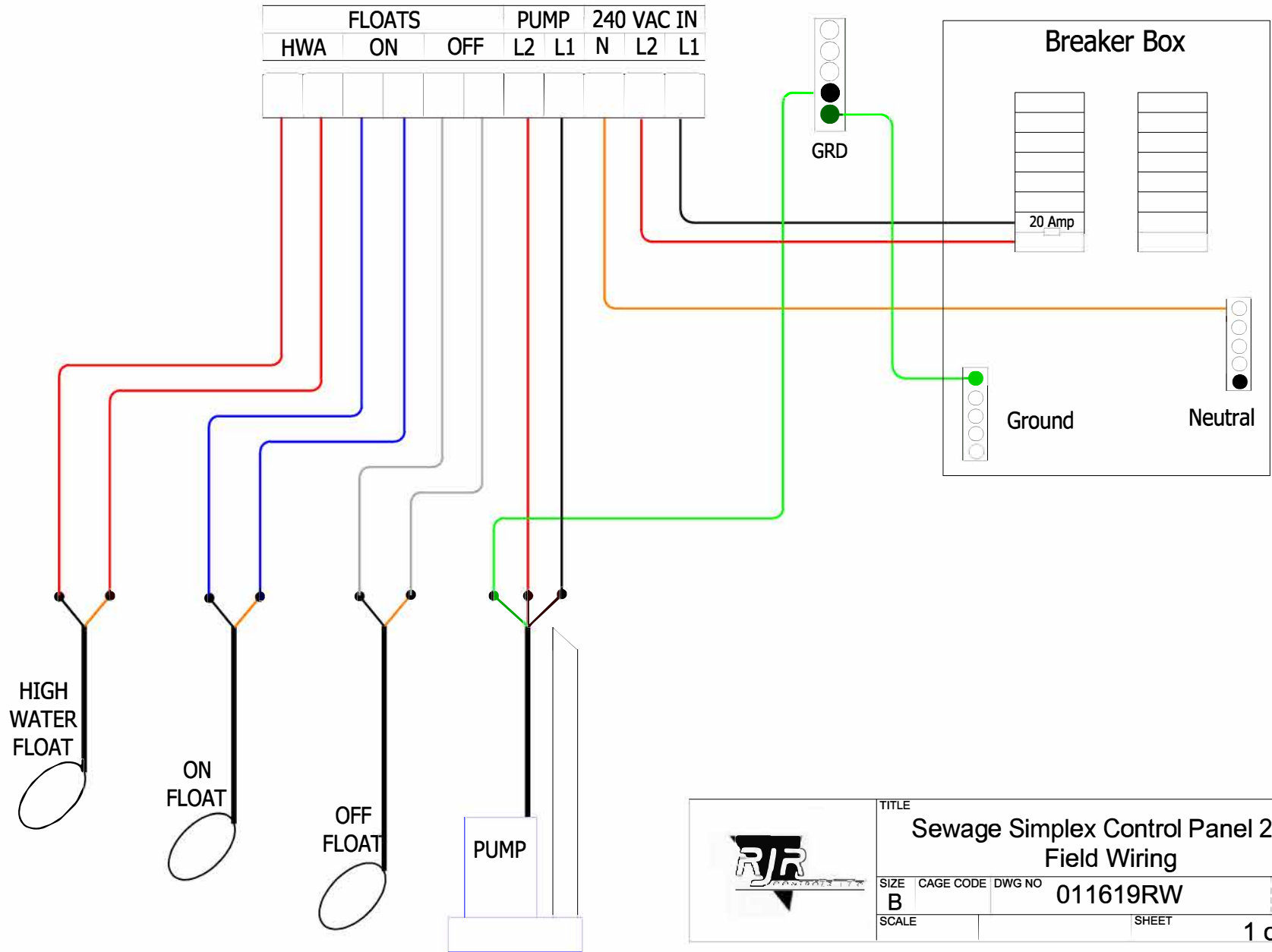

Sewage Simplex Control Panel 220V



- Lift Station control for 240 VAC 2 HP or less pump.
- Pump operation will be on demand using an on float and off float.
- Pump Test switch inside the enclosure.
- High water alarm will use a N/O float.
- Alarm Test and Silence switch in the door.
- Enclosure H x W x D = 10 x 8 x 4"



	TITLE			
	Sewage Simplex Control Panel 220V Field Wiring			
	SIZE	CAGE CODE	DWG NO	REV
	B		011619RW	0
SCALE			SHEET	1 of 1