

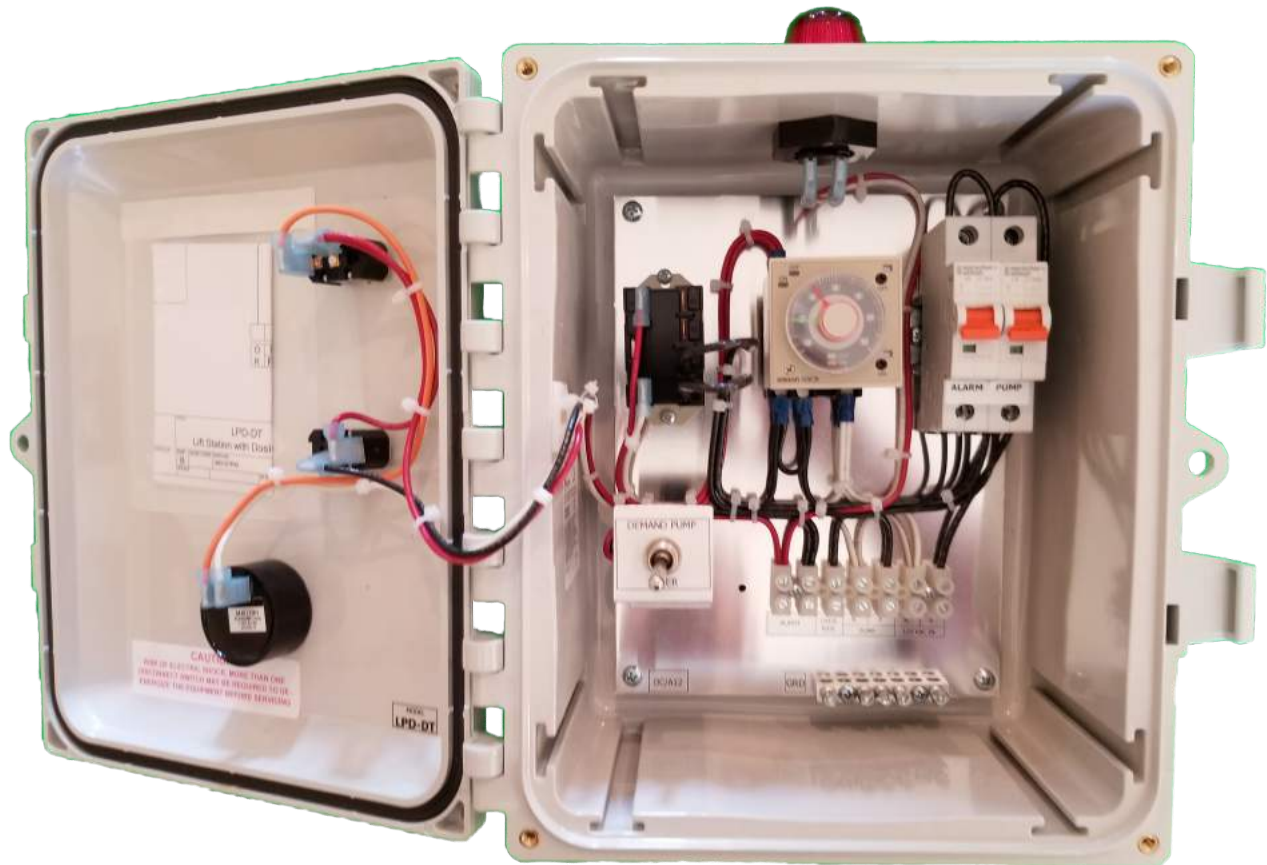

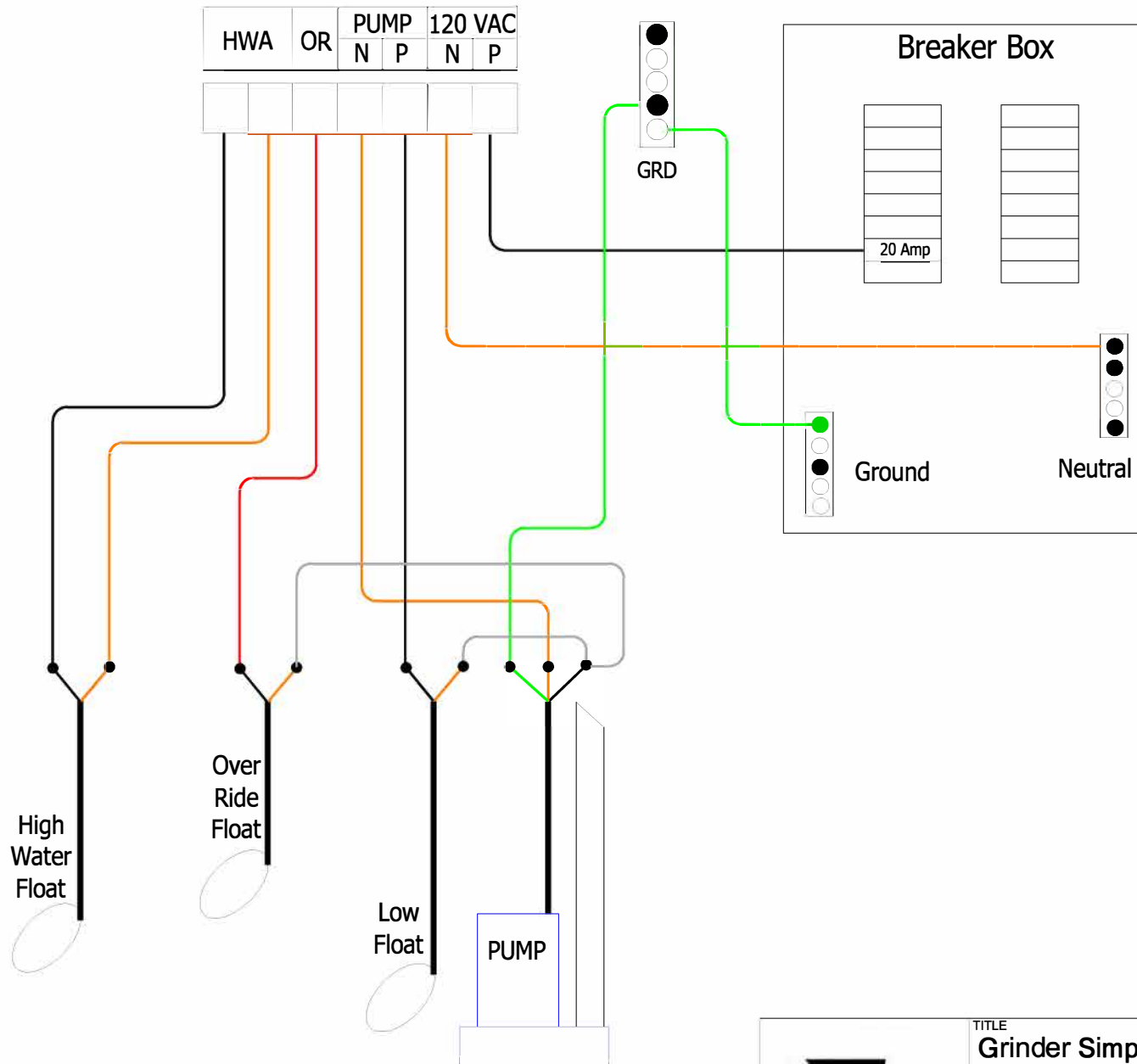

Grinder Simplex Dosing Timer Control Panel 120V



- Lift Station control for 120 VAC ½ HP or less pump.
- Pump operation will use a Omron H3CR dosing timer.
- Demand Pump Timer switch inside the enclosure.
- High water alarm will use a N/O float.
- Alarm Test and Silence switch in the door.
- Enclosure H x W x D = 10 x 8 x 4"



	TITLE Grinder Simplex Dosing Timer Control Panel 120V Field Wiring			
	SIZE B	CAGE CODE	DWG NO 011619RW	REV 0
	SCALE	SHEET		1 of 1