

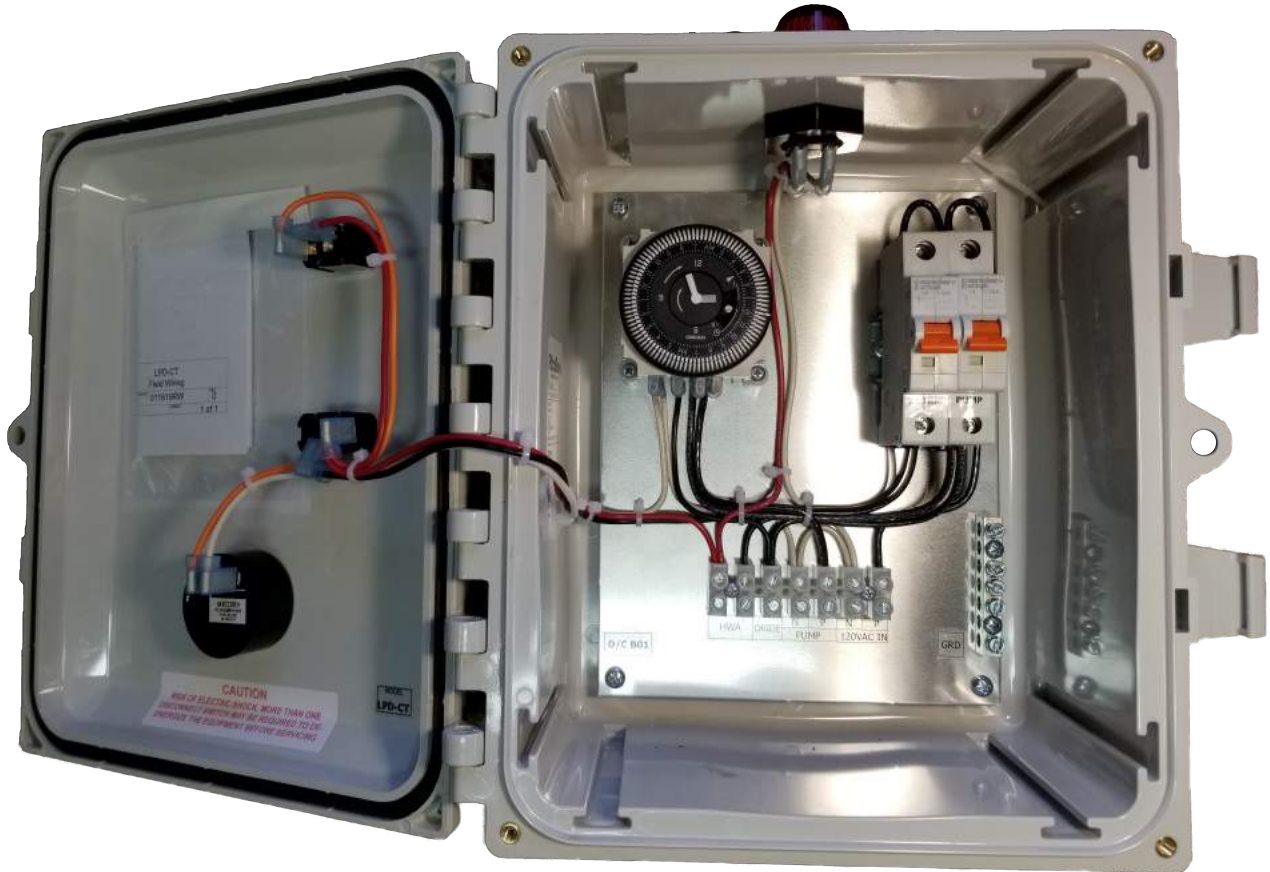

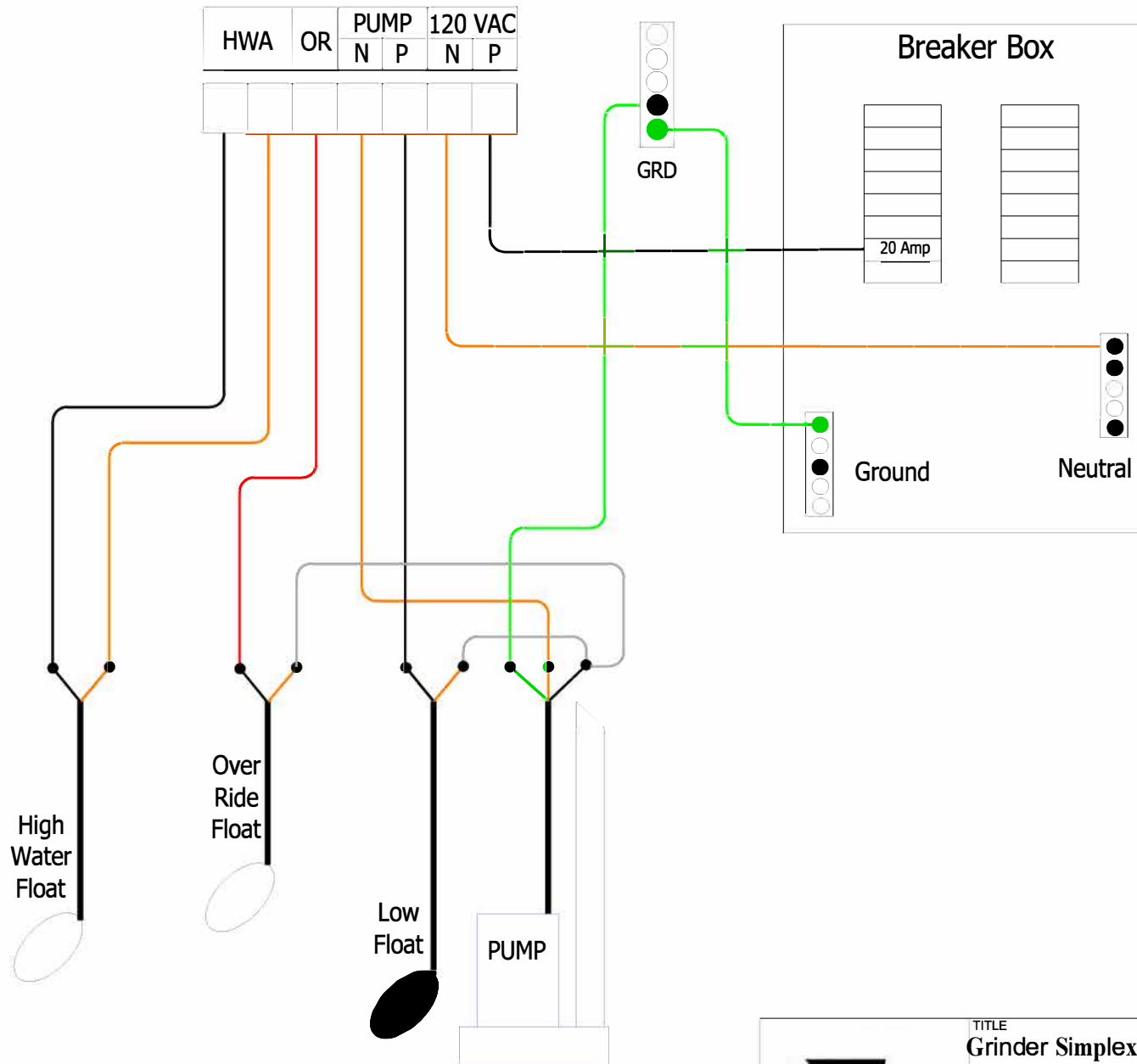

# Grinder Simplex Clock Timer Control Panel



- Lift Station control for 120 VAC ½ HP or less pump.
- Pump operation will use a Grasslin 15 minute pin timer.
- Demand Pump Timer switch inside the enclosure.
- High water alarm will use a N/O float.
- Alarm Test and Silence switch in the door.
- Enclosure H x W x D = 10 x 8 x 4"



				TITLE	
				Grinder Simplex Clock Timer Control Panel 120V	
				Field Wiring	
SIZE	CAGE CODE	DWG N <sup>o</sup>	REV		
B		011619RW	0		
SCALE				SHEET	1 of 1