

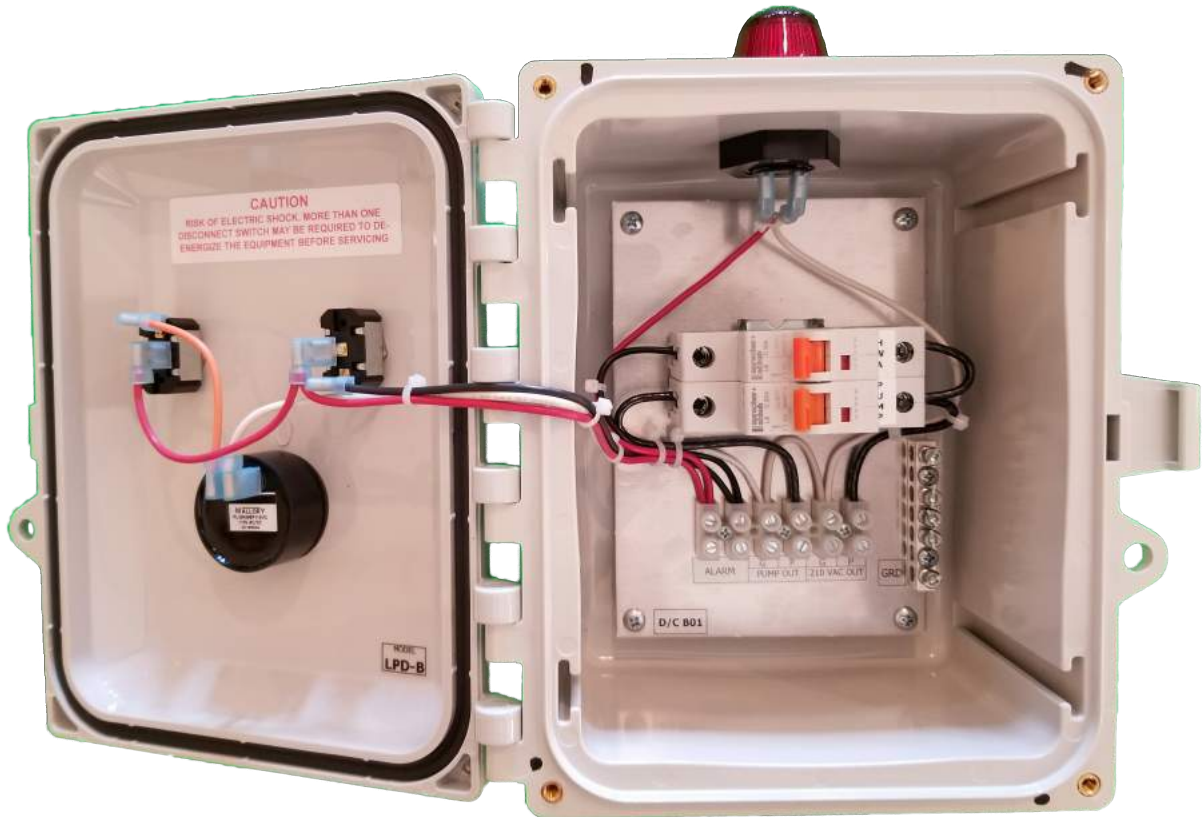

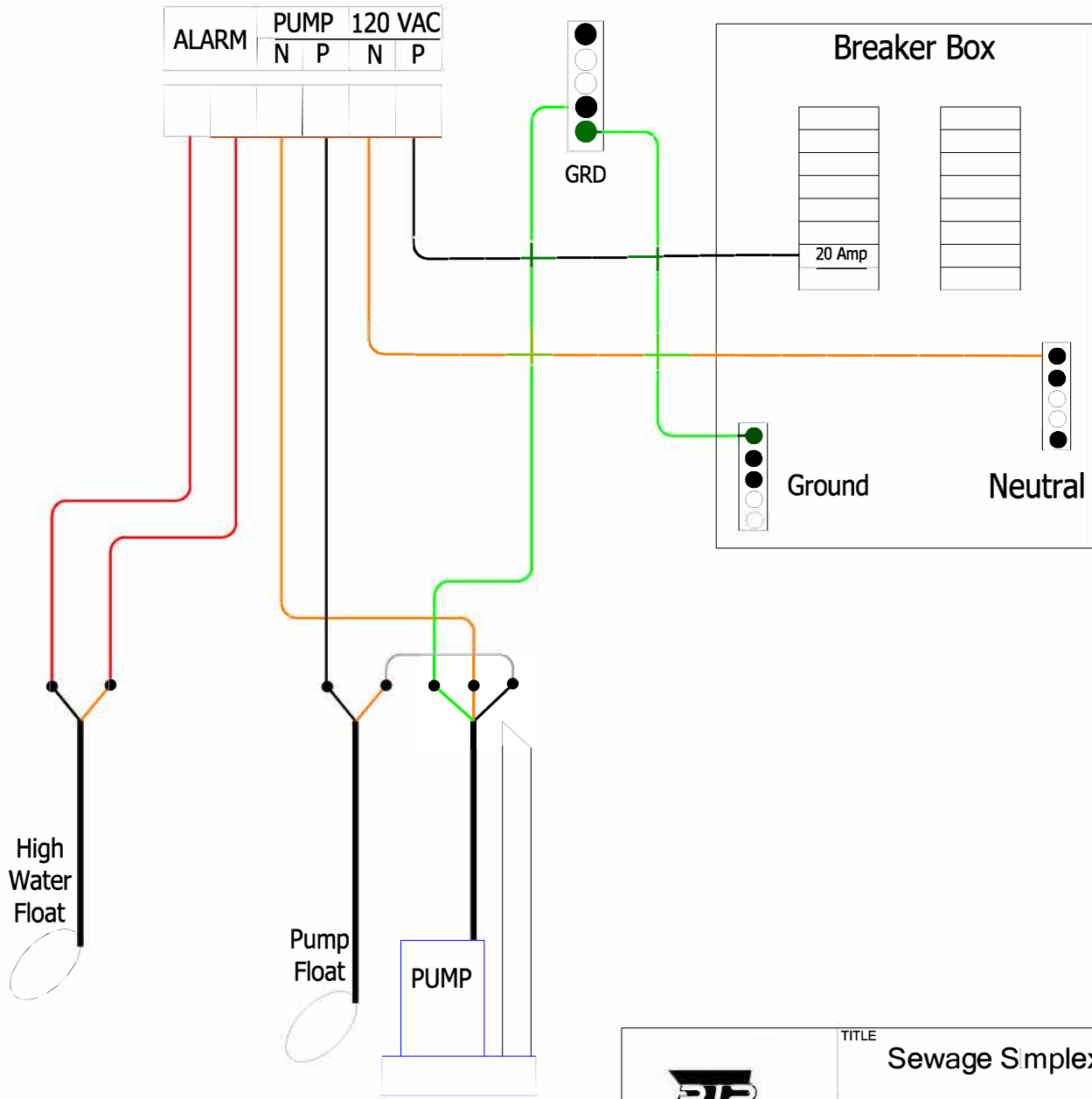

# Sewage Simplex Control Panel 120V



- Lift Station control for 120 VAC ½ HP or less pump.
- Pump operation will be on demand.
- High water alarm will use a N/O float.
- Alarm Test and Silence switch in the door.
- Enclosure H x W x D = 8 x 6 x 4"



	TITLE			Sewage Simplex Control Panel 120V Field
	SIZE	CAGE CODE	DWG NO	REV
	B		011819RW	0
SCALE	SHEET		1 of 1	