

# MEDO LA45 PUMP UNIT

## Product Features:

- Highly reliable, unique, die cast piston Construction
- UL-approved for outdoor use
- Integrated grounded line cord
- Service life expectancy of 6 years with Proper installation and periodic maintenance



Max Flow (lpm)	45
Max Cont. Operating Max Pressure (PSI)	1.56
Power Consumption (watts)	45
Noise Level (dBa @ 1m.)	38
Weight (lb)	6.6

## DIMENSIONS

## PERFORMANCE CURVES

### DIMENSIONS

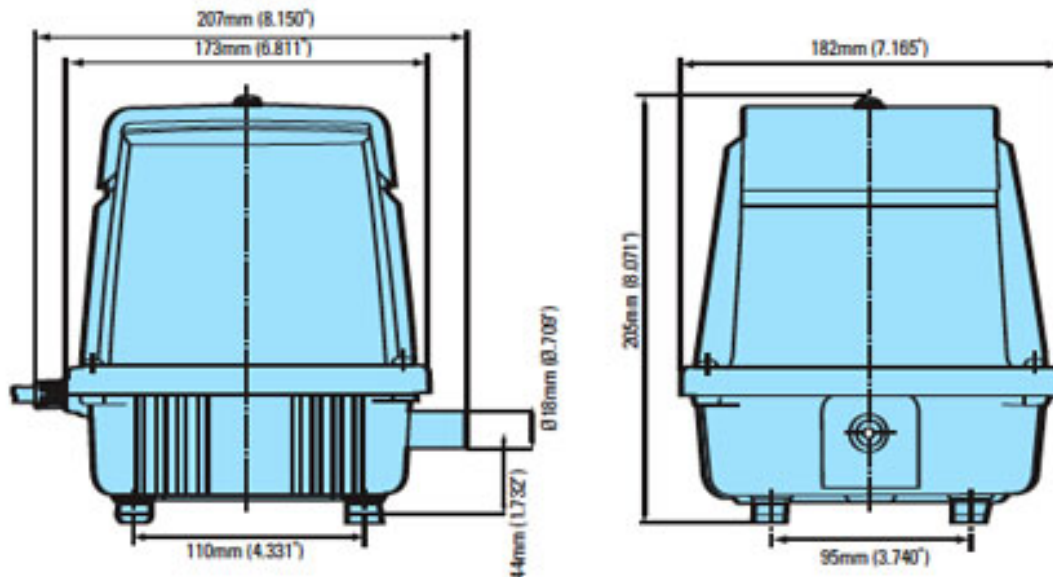

### AIR FLOW CHARACTERISTICS

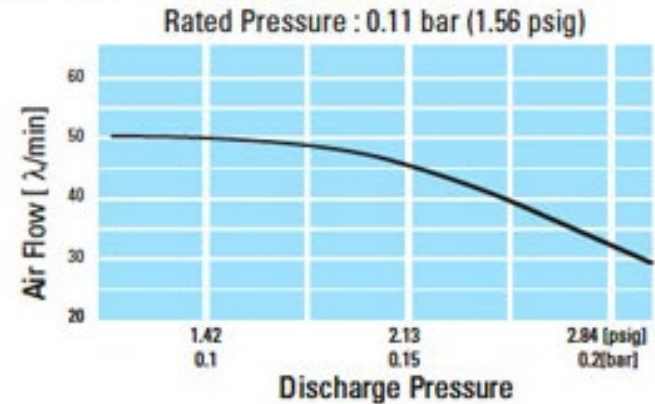

## SPECIFICATIONS FOR MEDO LA45

- 2.54 cfm Max Air Flow
- 60 Liters of Air Per Minute
- 4.63 psi Max Continuous Operating Pressure
- 120VAC, 60 Hz, 1.0A, 45 Watts
- Dimensions: 8.15" L x 7.16" W x 8.07" H
- 38 dBA @ 1 meter
- Includes Rubber 90 Connection Fitting
- UL Rated for Outdoor Use

