

MEDO LA100 PUMP UNIT

Product Features:

- Highly reliable, unique, die cast piston Construction
- UL-approved for outdoor use
- Integrated grounded line cord
- Service life expectancy of 6 years with Proper installation and periodic maintenance



Max Flow (lpm)	100
Max Cont. Operating Max Pressure (PSI)	3.56
Power Consumption (watts)	95
Noise Level (dBa @ 1m.)	48
Weight (lb)	20.7

DIMENSIONS

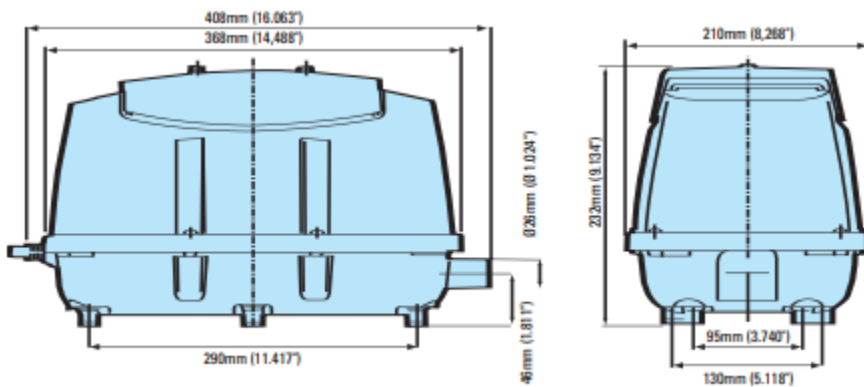

PERFORMANCE CURVES

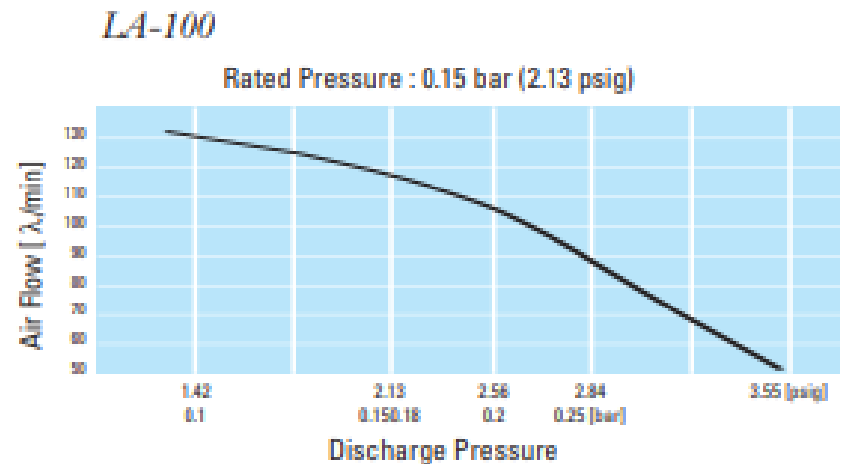

SPECIFICATIONS FOR MEDO LA100

- 3.53 cfm Max Air Flow
- 100 Liters of Air Per Minute
- 5.12 psi Max Continuous Operating Pressure
- 120VAC, 60 Hz, 1.7A, 95 Watts
- 48 dBA @ 1 meter
- Dimensions: 16.1" L X 8.27" W X 9.13" H
- Includes Rubber 90 and Alarm Connection Fittings
- UL Rated for Outdoor Use

