

# HP-60 UNIT

## Product Details:

- Available with Integral low-pressure alarms for 120 VAC applications
- Standard UL approved 120 VAC models, and 230 VAC CE compliant models available.
- Pumps equipped with thermal overload protection
- Includes pressure tap location for external alarm sensor



Max Flow (lpm)	60
Max Cont. Operating Max Pressure (PSI)	2.13
Power Consumption (watts)	51
Noise Level (dBa @ 1m.)	35
Weight (lb)	15.4

## DIMENSIONS

[Unit: mm(inch)]

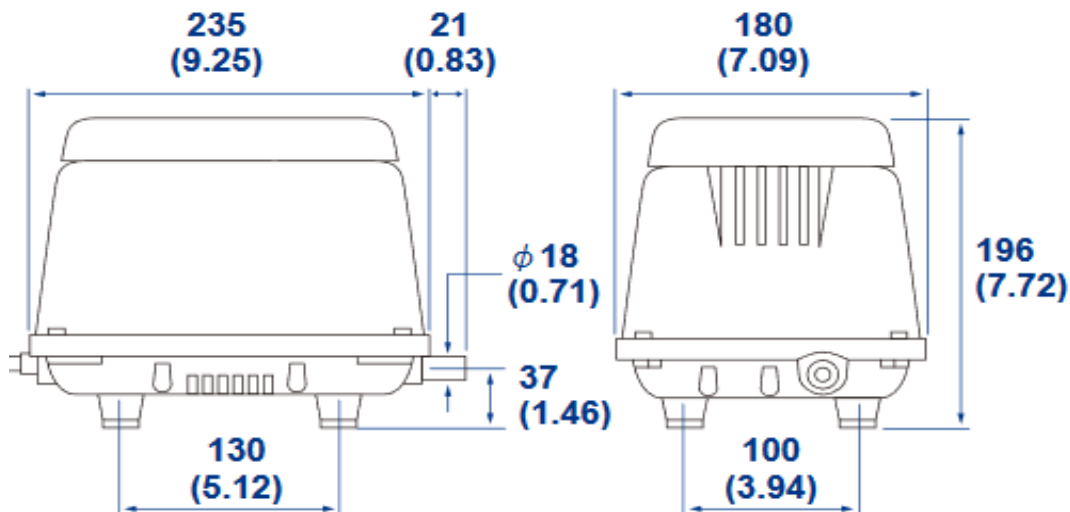

## PERFORMANCE CURVES

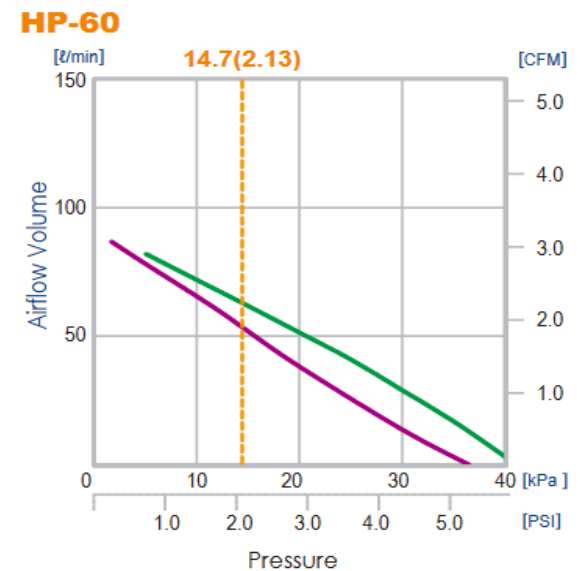
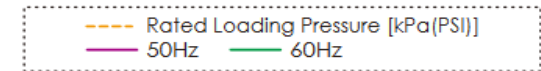

## SPECIFICATIONS FOR HIBLOW HP-60 UNIT

- 3.5 cfm (cubic feet per minute) Maximum Air Flow (@ 0 PSI)
- 60 LPM (Liters Per Minute) @ 2.13 PSI
- 3.6 PSI Maximum Continuous Operating Pressure
- 120 VAC, 60 Hz, 1.3A, 51 Watts
- 35 dBA Measured @ 1 Meter
- Dimensions: 9.3" L x 7.1" H x 7.8" H
- Condition: NEW
- Includes Rubber 90 with Hose Clamps
- Includes 1/8" Alarm Connection Fitting

