

HP-40 UNIT

Product Details:

- Available with Integral low-pressure alarms for 120 VAC applications
- Standard UL approved 120 VAC models, and 230 VAC CE compliant models available.
- Pumps equipped with thermal overload protection
- Includes pressure tap location for external alarm sensor



Max Flow (lpm)	40
Max Cont. Operating Max Pressure (PSI)	1.42
Power Consumption (watts)	38
Noise Level (dBa @ 1m.)	32
Weight (lb)	12.6

DIMENSIONS

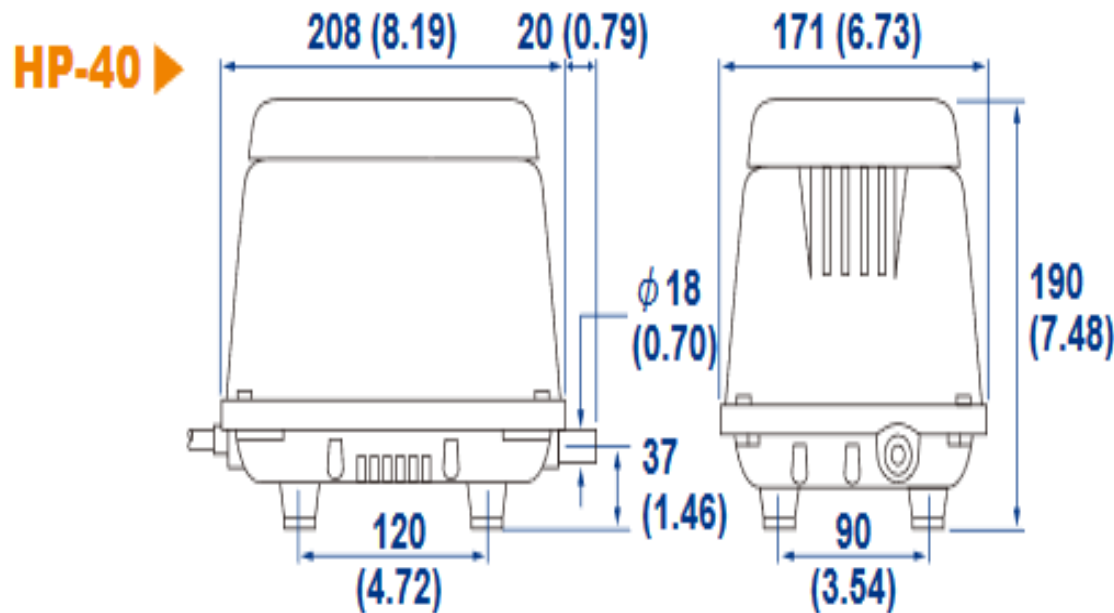

PERFORMANCE CURVES

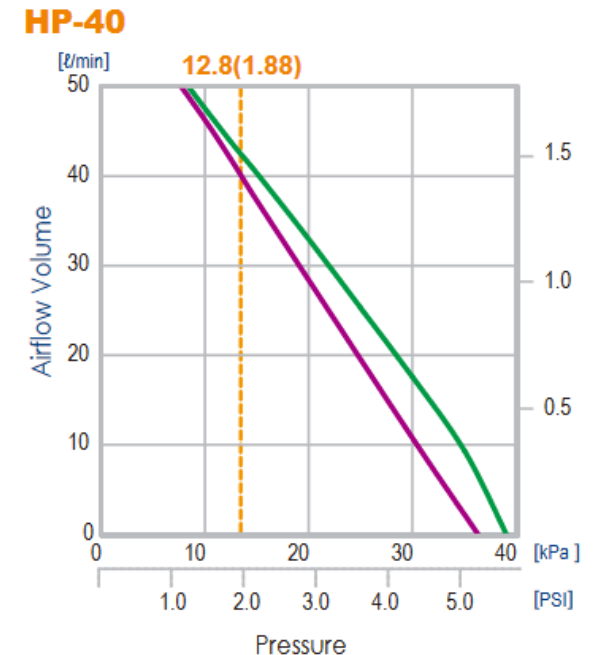

SPECIFICATIONS FOR HIBLOW HP-40 UNIT

- 2.8 cfm (cubic feet per minute) Maximum Air Flow (@ 0 PSI)
- 40 LPM (Liters Per Minute) @ 1.42 PSI
- 1.42 PSI Maximum Continuous Operating Pressure
- 120 VAC, 60 Hz, 0.8A, 38 Watts
- 32 dBA Measured @ 1 Meter
- Dimensions: 8.2" L x 6.7" H x 7.5" H
- Condition: NEW
- Includes Rubber 90 with Hose Clamps
- Includes 1/8" Alarm Connection Fitting

