

HIBLOW HP-120A

Product Details:

- Pumps equipped with thermal overload protection
- Integral low-pressure alarm
- Single Port
- 6' power cord
- Quiet operation, 40 dBA



Rated Voltage (VAC)	120
Power Consumption (Watts)	125
Rated Pressure (PSI)	3.6
Rated Air Flow (lpm @ Rated Pressures)	120
Maximum Airflow (lpm @ 0 PSI)	150
Max. Cont. Operating Pressure (PSI)	3.6
Rated Pressure Range (PSI)	2.57
Noise Level (dBA)	40
Weight (lb.)	19.5

DIMENSIONS

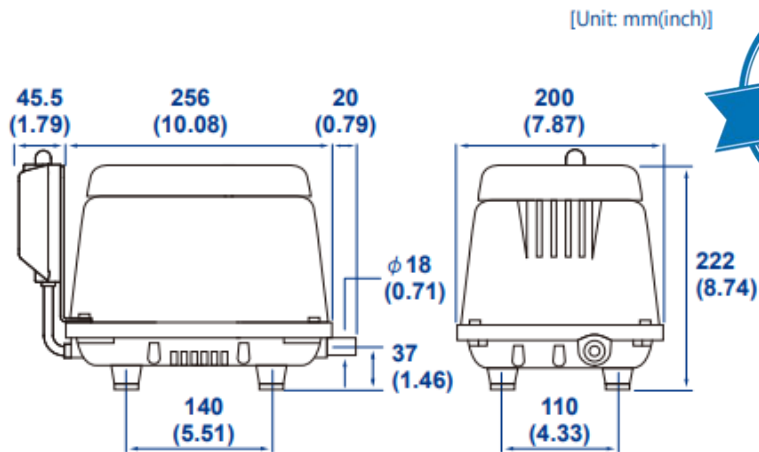

PERFORMANCE CURVES

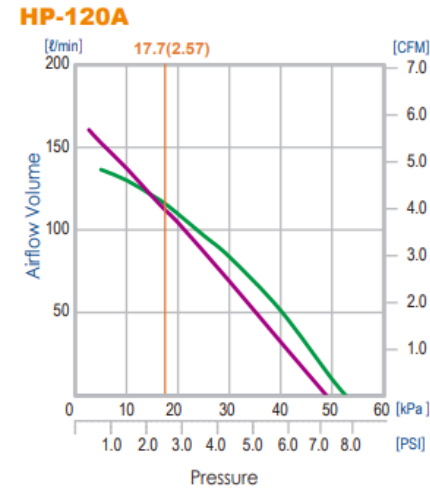

Performance Curves

- Rated Loading Pressure [kPa(PSI)]
- 50Hz — 60Hz

