

Blue Diamond ET120

Product Details:

- Linear Diaphragm air pump
- Quiet Operation
- Oil free operation
- Thermal over load protection



Rated Voltage	120	Volts
Power supply Frequency	60	Hz
Power Consumption	90	W
Maximum Pressure	1.45	PSI
Airflow at maximum Pressure	120	L / min
	4.24	cfm
Sound level	45	dB
Weight	21	lbs.
Length	10.5	In
Width	8.4	In
Height	7.8	In
Outlet Outer Diameter	0.71	In



DIMENSIONS (in)

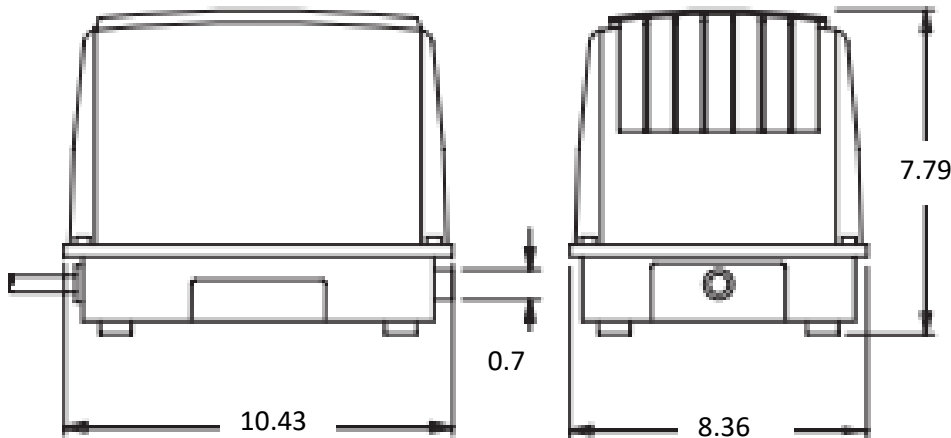

PERFORMANCE CURVE

