

SECOH EL80A

Product Details:

- Long life expectancy
- High Degree of Efficiency
- Low Noise Level, Low Vibration
- Oil Free, Pulsation Free Air Flow
- Weatherproof



Max Flow (lpm)	80
Max Cont. Operating Max Pressure (PSI)	2.1
Power Consumption (watts)	61
Noise Level (dBa @ 1m.)	40
Weight (lb)	18.7

DIMENSIONS

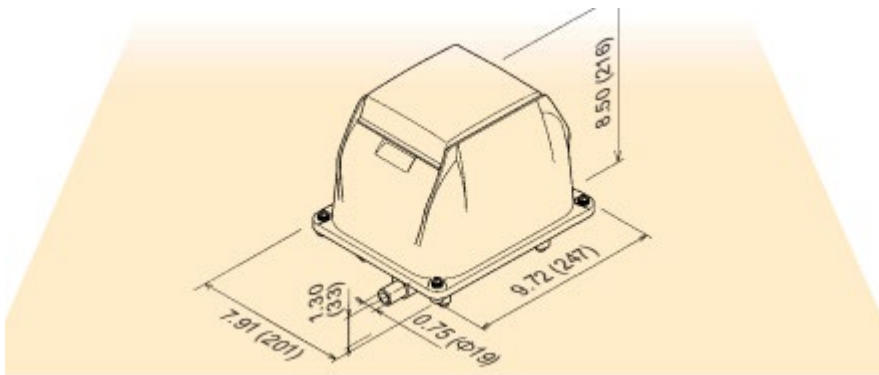

PERFORMANCE CURVES

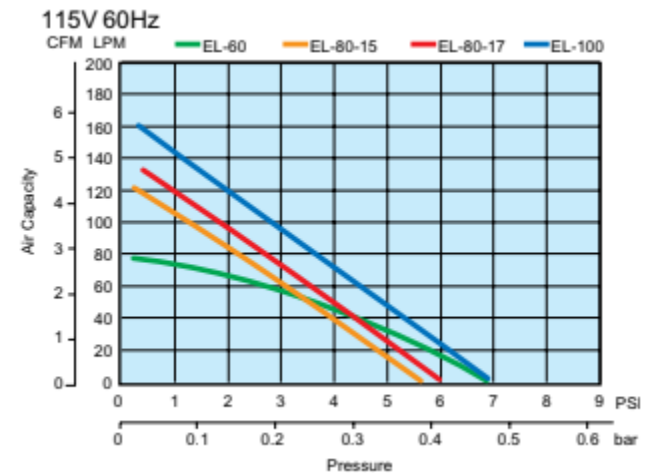

SPECIFICATIONS FOR SECOH EL80A

- 4.23 C.F.M Max Air Flow
- 80 LPM (Liters Per Minute)
- 2.3 C.F.M @ 2.1 PSI
- 115 VAC, 60 Hz, 2.6A, 61 Watts
- Dimensions: 9.72" L x 7.91" W x 8.50" H
- Includes Rubber 90 Connection Fitting
- Includes air barb for alarm hose
- UL Rated for Outdoor Use
- 2 Year Warranty

