

SECOH EL60

Product Details:

- Rainproof enclosure - conforms to UL1450
- Quiet operation, 33 dBA
- Easy maintenance - occasional filter change necessary
- Low power consumption, vibration & pulsation, smooth airflow delivery
- Oil free operation - guarantees contamination free airflow



Max Flow (lpm)	60
Max Cont. Operating Max Pressure (PSI)	2.1
Power Consumption (watts)	56
Noise Level (dBA @ 1m.)	33
Weight (lb)	18.7

DIMENSIONS

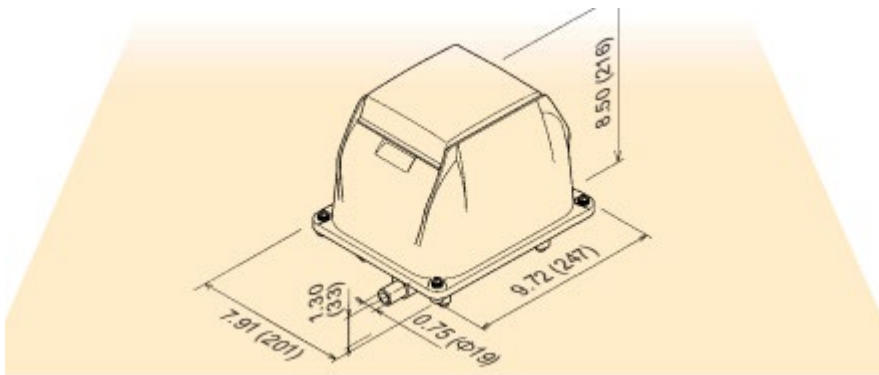

PERFORMANCE CURVES

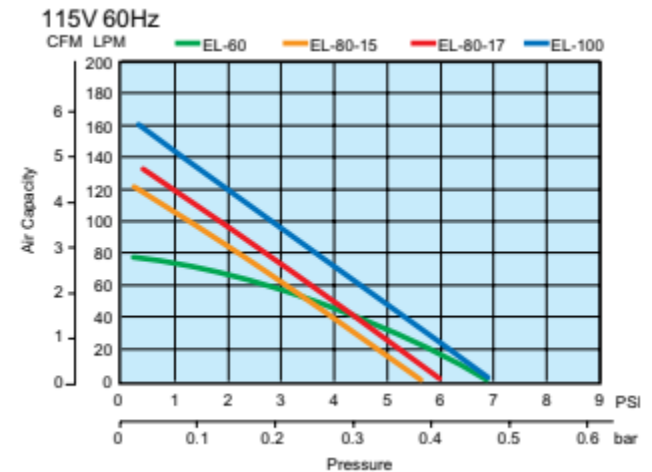

SPECIFICATIONS FOR SECOH EL60

- 2.8 C.F.M Max Air Flow
- 65 LPM (Liters Per Minute)
- 2.3 C.F.M @ 2.1 PSI
- 120 VAC, 60 Hz, 1.6A, 56 Watts
- Dimensions: 9.72" L x 7.91" W x 8.50" H
- Includes Rubber 90 Connection Fitting
- Includes air barb for alarm hose
- UL Rated for Outdoor Use
- 2 Year Warranty

