

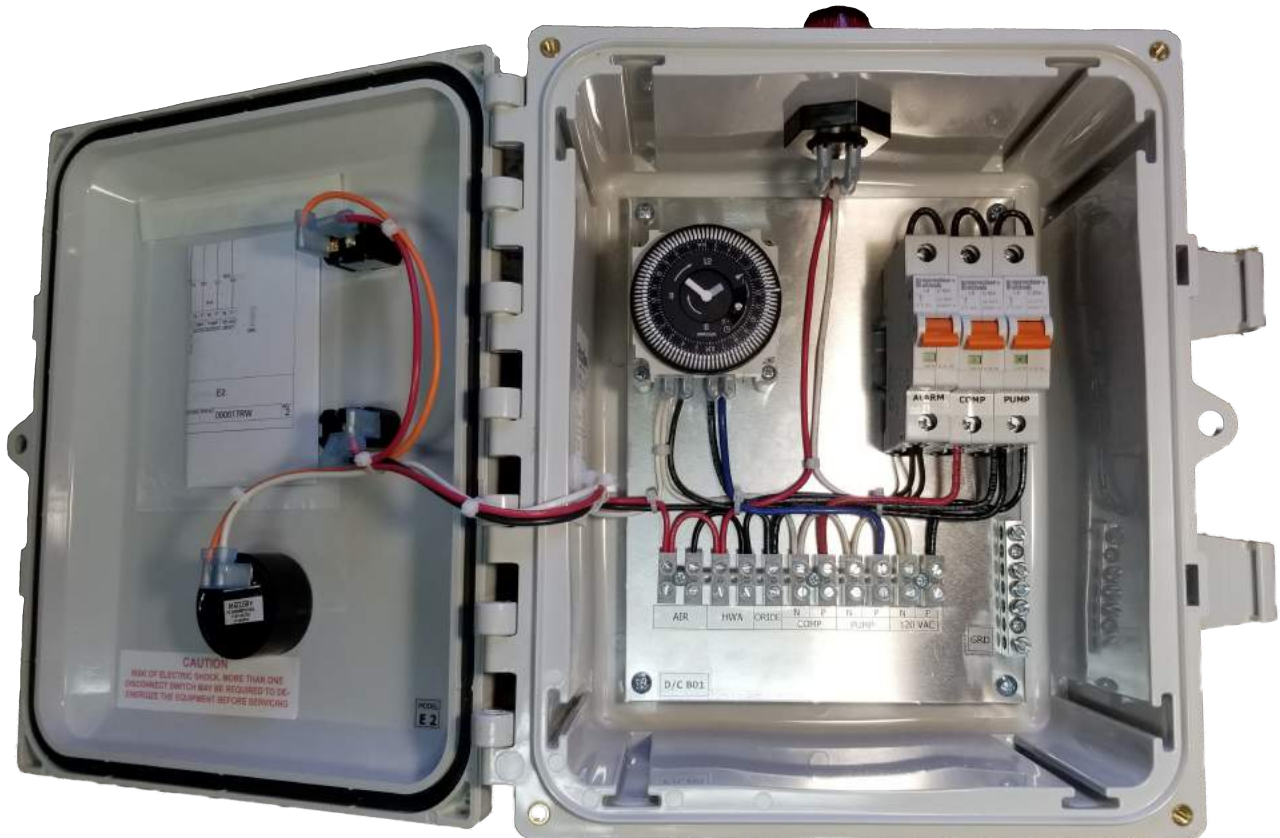

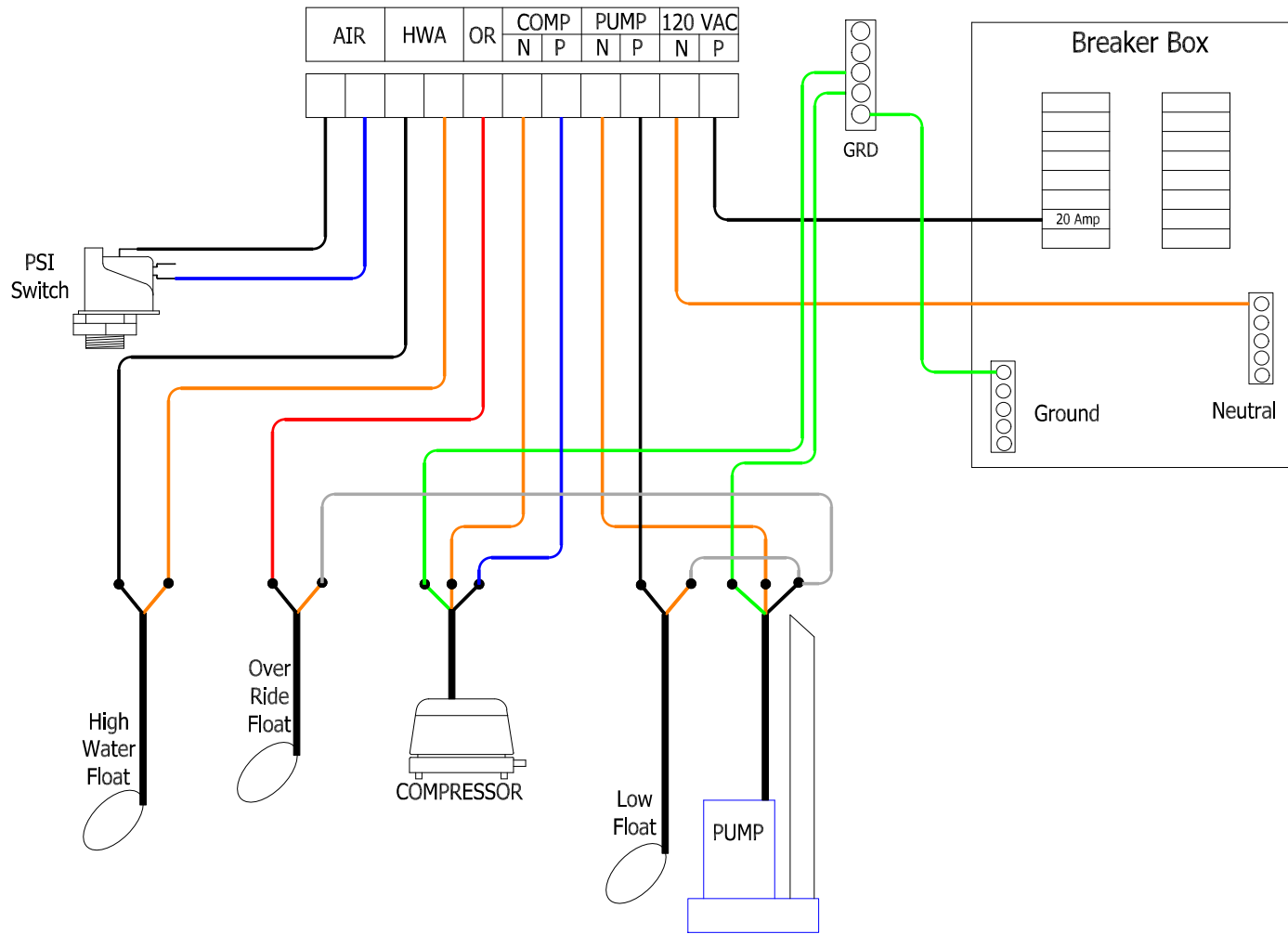

E2



- Aerobic treatment units with rotary or linear compressor.
- Aerator alarm will use included pressure switch.
- Pump operation will use an Grasslin 15 minute pin timer.
- High water alarm and timer over ride will use a N/O float.
- Shared alarm light.
- Alarm Test and Silence switch in the door.
- Enclosure H x W x D = 10 x 8 x 4"



		TITLE		E2 Field Wiring	
		SIZE B	CAGE CODE	DWG NO 011619RW	REV 0
SCALE		SHEET		1 of 1	