

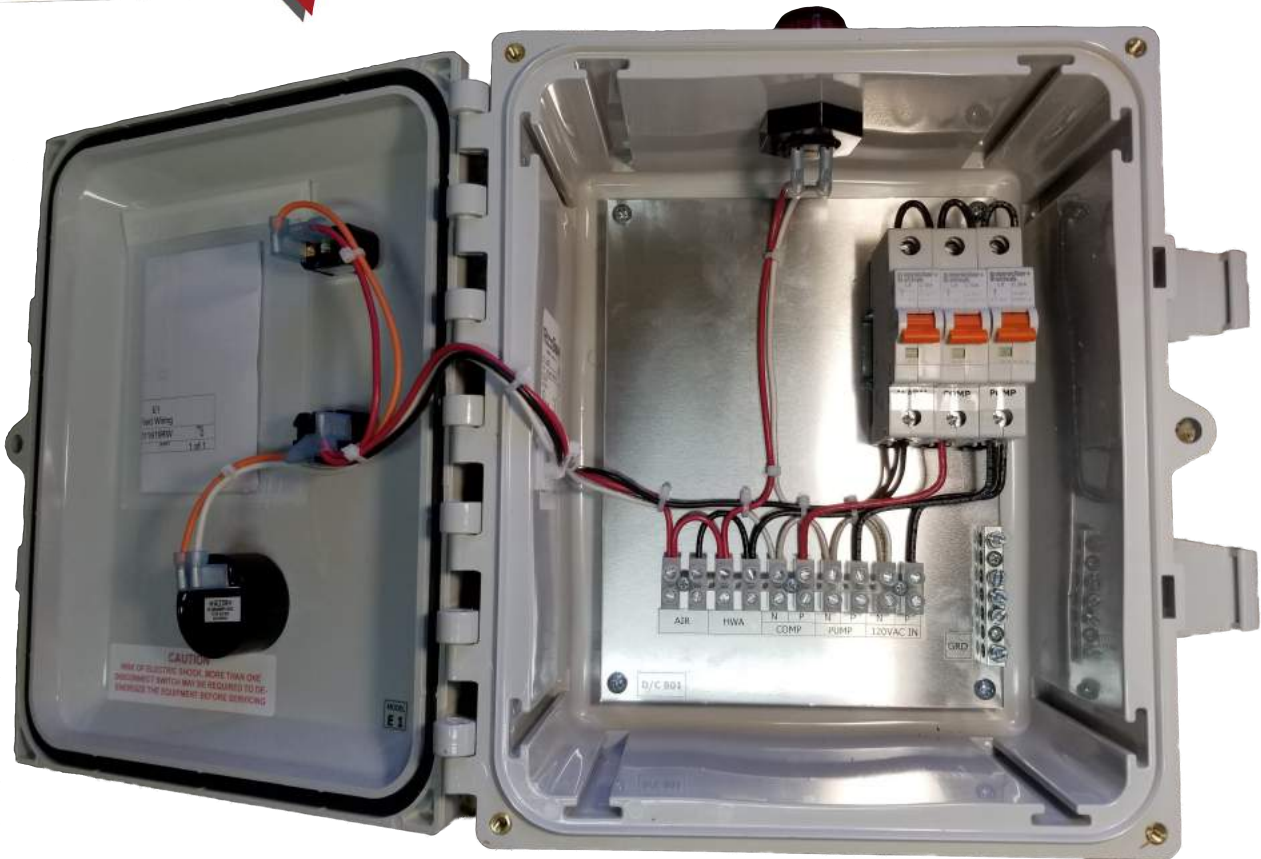

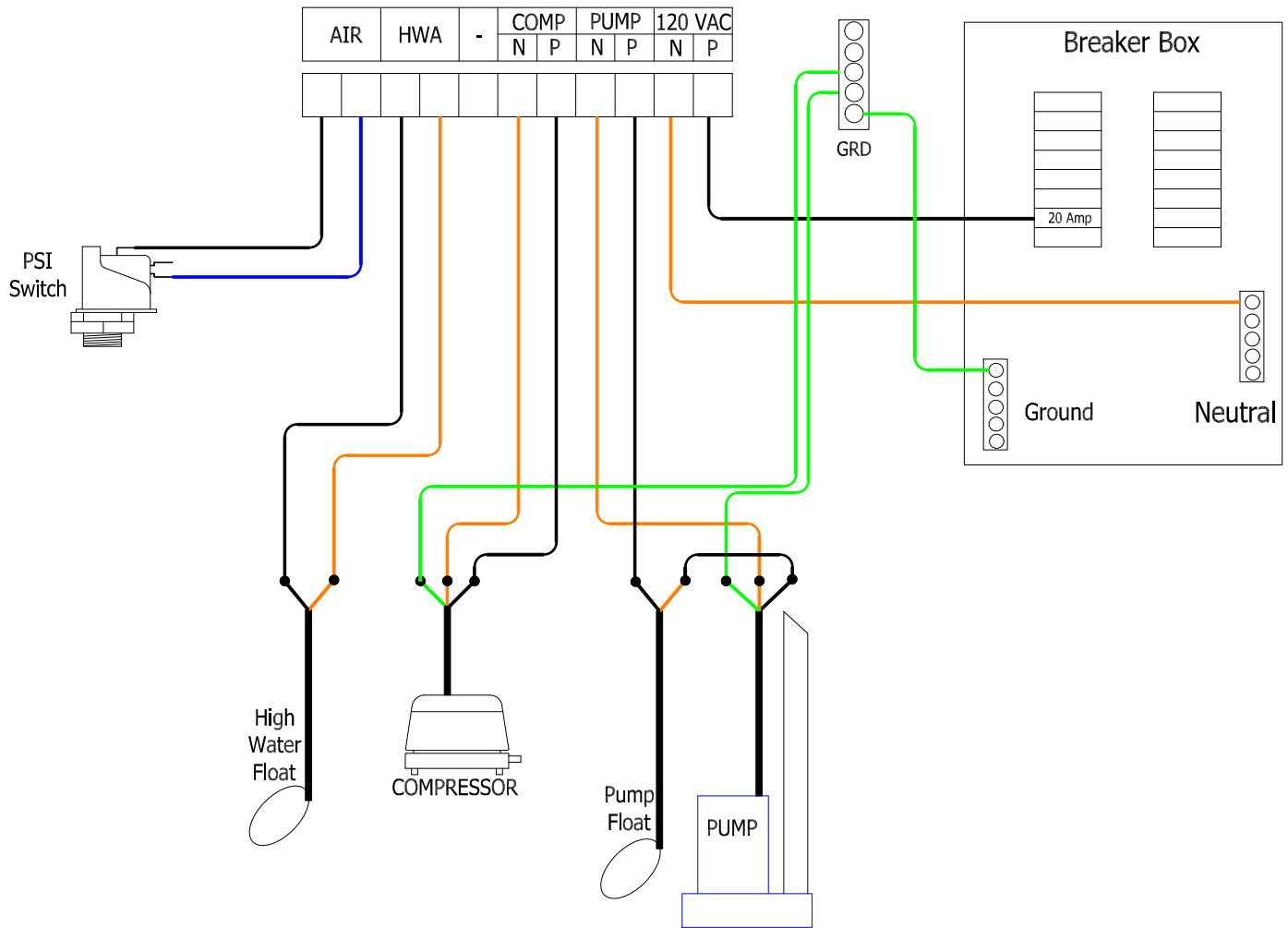

# E1



- Aerobic treatment units with rotary or linear compressor.
- Aerator alarm will use included pressure switch.
- Pump operation will be on demand.
- High water alarm and timer over ride will use a N/O float.
- Shared alarm light.
- Alarm Test and Silence switch in the door.
- Enclosure H x W x D = 10 x 8 x 4"



	TITLE			E1 Field Wiring	
	SIZE	CAGE CODE	DWG NO	REV	
	B		011619RW	0	
SCALE	SHEET			1 of 1	