

HIBLOW DUO-60

Product Details:

- Includes pressure tap location for external alarm sensor
- Equipped with thermal overload protection
- 6' power cord
- User friendly timer
- Dual outlet ports with integrated cam-style valves and programmable timer controller to alternate between two aeration processes



| | |
|--|----------|
| Rated Voltage (VAC) | 120 |
| Power Consumption (Watts) | 39 |
| Rated Pressure (PSI) | 2.13 |
| Rated Air Flow (lpm @ Rated Pressures) | 60 |
| Maximum Airflow (lpm @ 0 PSI) | 100 |
| Max. Cont. Operating Pressure (PSI) | 2.9 |
| Rated Pressure Range (PSI) | 0.73-3.4 |
| Noise Level (dBA) | 35 |
| Weight (lb.) | 13.2 |

DIMENSIONS

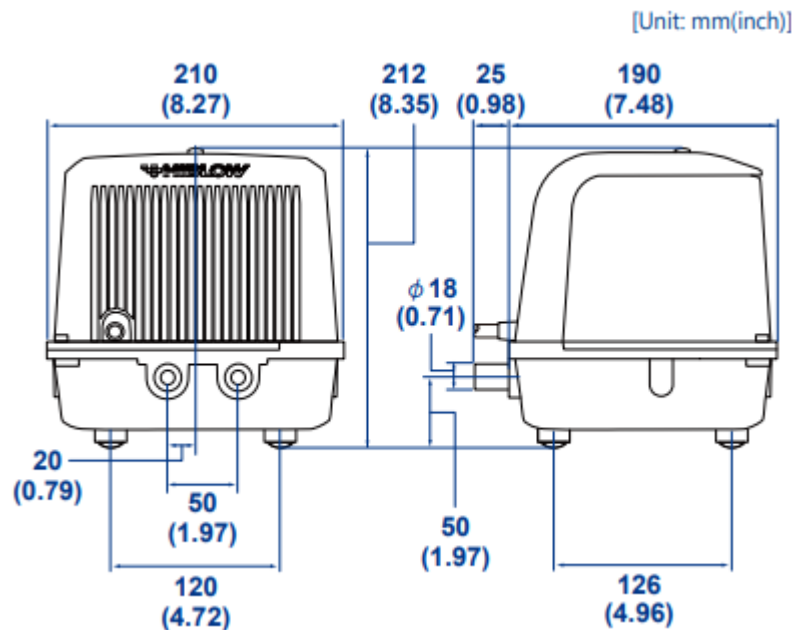

PERFORMANCE CURVES

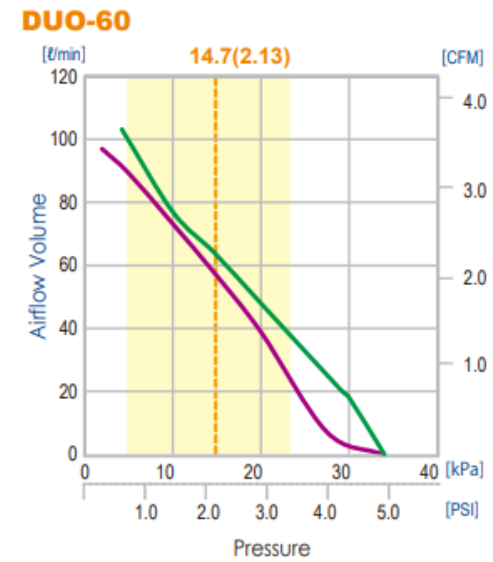

Performance Curves

--- Rated Loading Pressure [kPa(PSI)]
— 50Hz — 60Hz Pressure range for use

SPECIFICATIONS FOR HIBLOW DUO-60

- 3.5 cfm / 100 lpm maximum air flow (@ 0 PSI)
- 60 lpm (Liters Per Minute) @ 2.13 PSI
- 2.9 PSI maximum continuous operating pressure
- 120 VAC, 60 Hz, 0.5 A, 39 W
- 35 dBA at a distance of one meter
- Dimensions 8.27'' x 7.48'' x 8.35''
- 0.73 PSI – 3.4 PSI rated pressure range
- 13.2 pounds

