

# GAST AT05-101-G215DX

## Product Details:

- Rotary Vane style air compressor
- Low air pulsation
- Low maintenance
- Thermal overload protection
- Oil free operation
- Heavy duty
- One-year warranty



Rated Voltage	Volts	115
Power supply Frequency	Hz	60
Current	Amps	4.7
Power	W (hp)	190 ( 1/4)
Rotations Per Minute	RPM	1725
Maximum Pressure	PSI	5
	L / min	135
Maximum Airflow	cfm	4.8
Sound level	dB(A)	Less than 60 dB(A)
Temperature Range	°F	33.8 – 104
Weight	lbs.	31
Length	In	13.58
Width	In	8.4
Height (without filter)	In	6.4



## DIMENSIONS

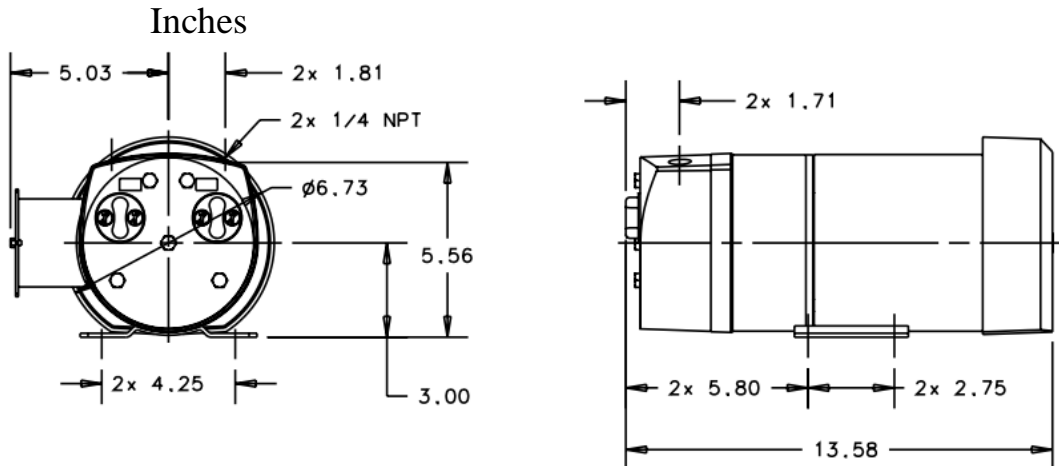

## PERFORMANCE CURVE

