

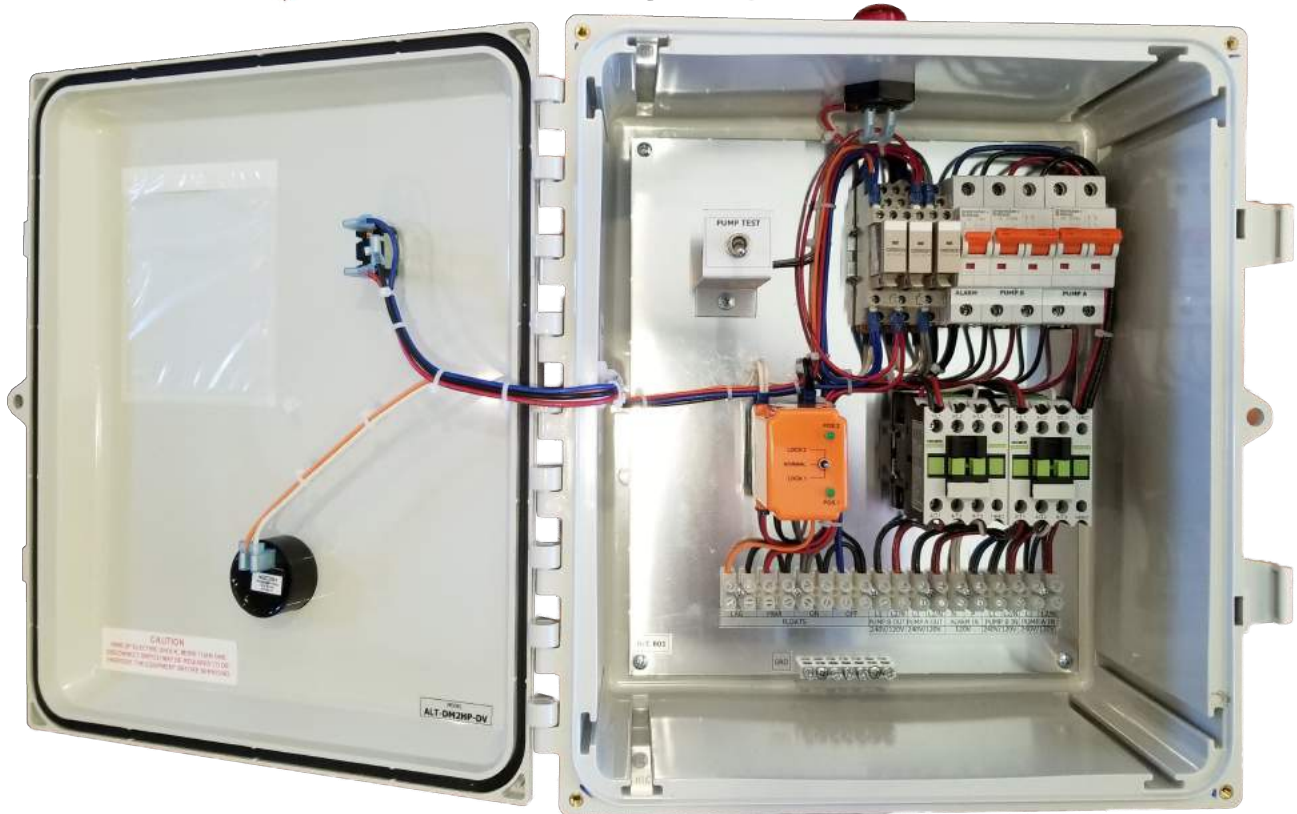

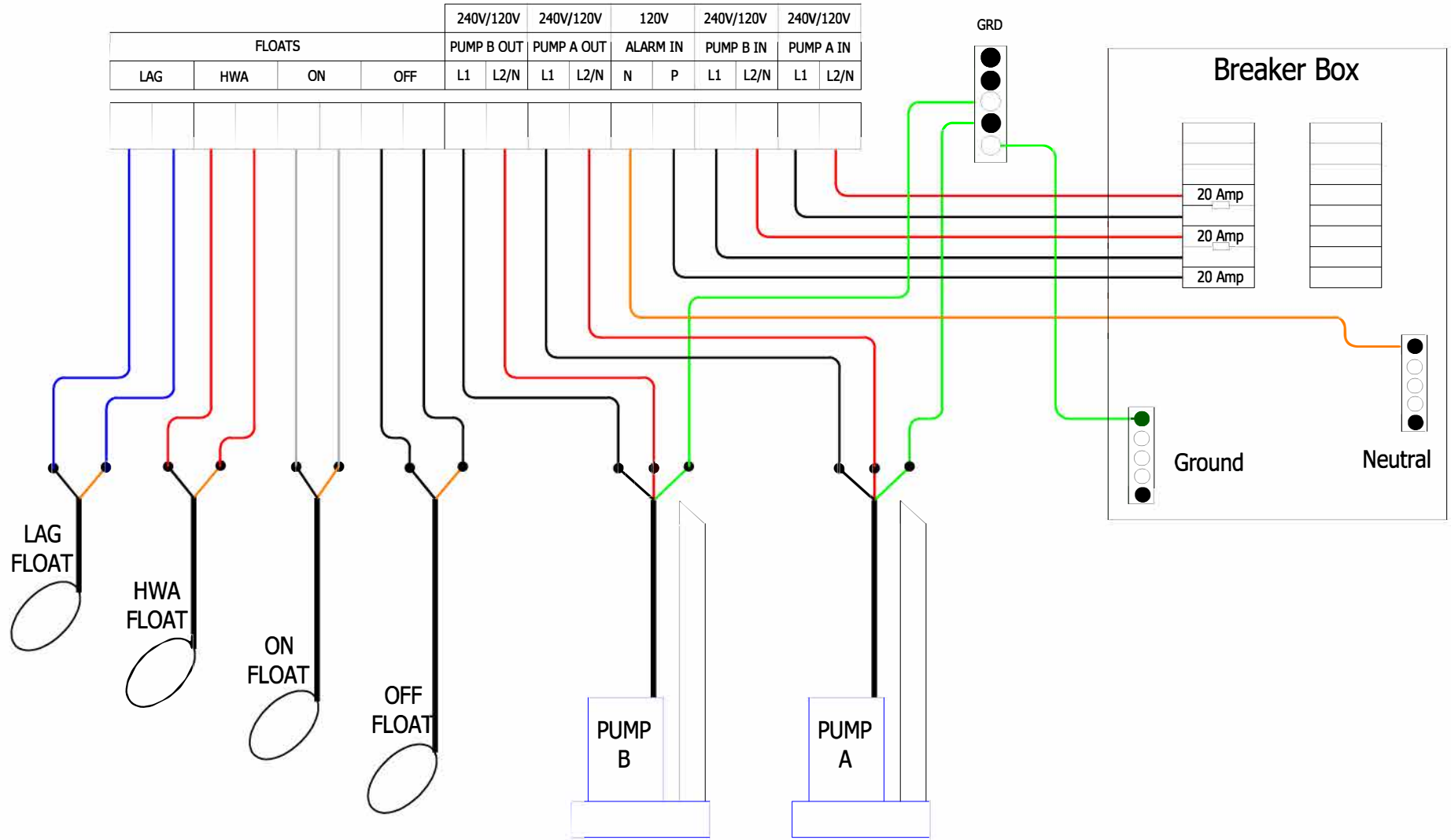

Sewage Pump Duplex Control Panel



- Dual Voltage duplex lift station for 120 VAC or 240 VAC up to 2 HP.
- Pump operation will be on demand using an on float and off float.
- Cross wired alternating relay with load lock switch for alternating pumps.
- Pump Test switch inside the enclosure.
- High water alarm will use a N/O float.
- Alarm Test and Silence switch in the door.
- Enclosure H x W x D = 14 x 12 x 6"



	TITLE				Sewage Pump Duplex Control Panel Field Wiring	
	SIZE	CAGE CODE	DWG NO	REV		
	B		011619RW	0		
SCALE				SHEET	1 of 1	