

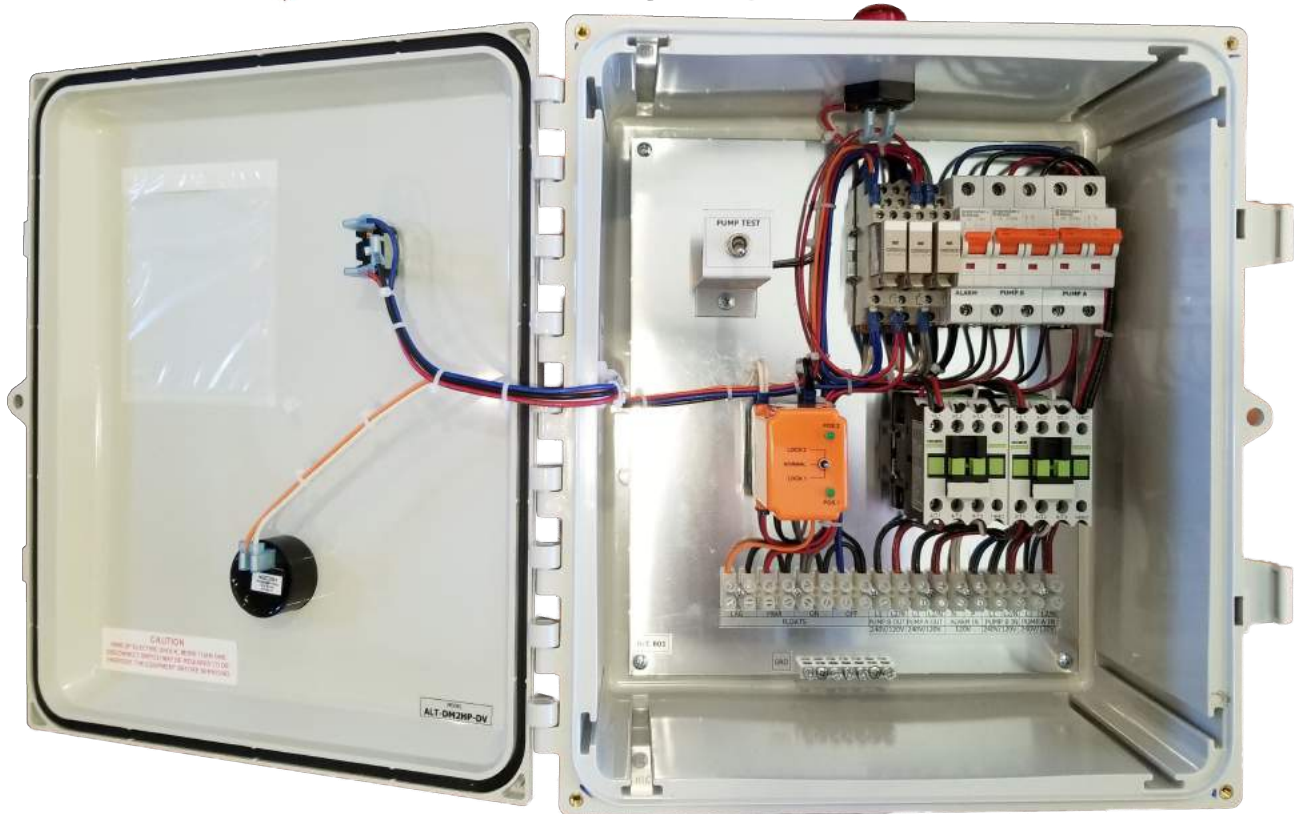

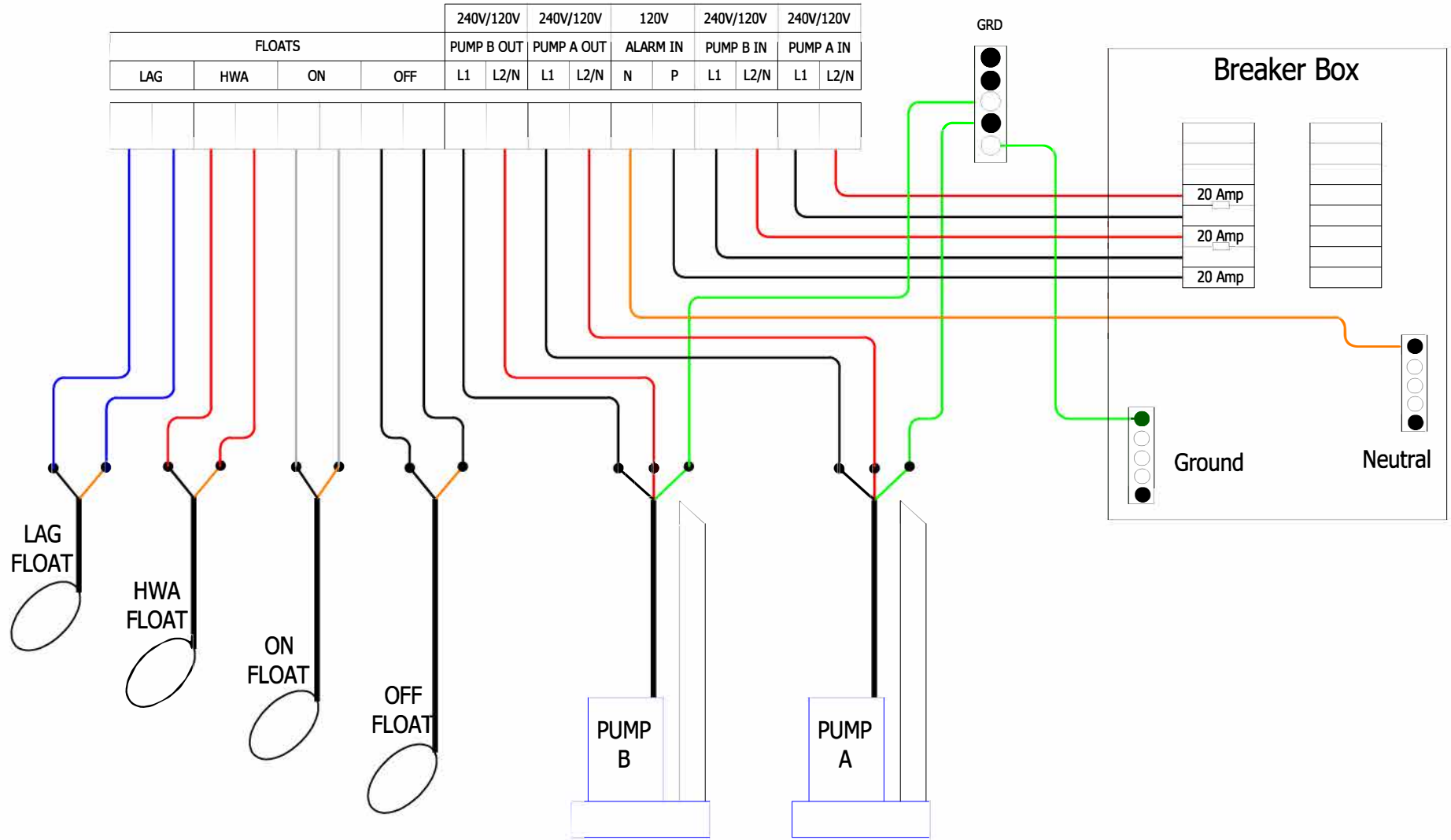

Grinder Pump Duplex Control Panel



- Dual Voltage duplex lift station for 120 VAC or 240 VAC up to 2 HP.
- Pump operation will be on demand using an on float and off float.
- Cross wired alternating relay with load lock switch for alternating pumps.
- Pump Test switch inside the enclosure.
- High water alarm will use a N/O float.
- Alarm Test and Silence switch in the door.
- Enclosure H x W x D = 14 x 12 x 6"



| | | | | |
|---|---|-----------|--------|-----|
|  | TITLE | | | |
| | Grinder Pump Duplex Control Panel Field Wiring | | | |
| | SIZE | CAGE CODE | DWG NO | REV |
| B | | 011619RW | 0 | |
| SCALE | SHEET | | 1 of 1 | |