

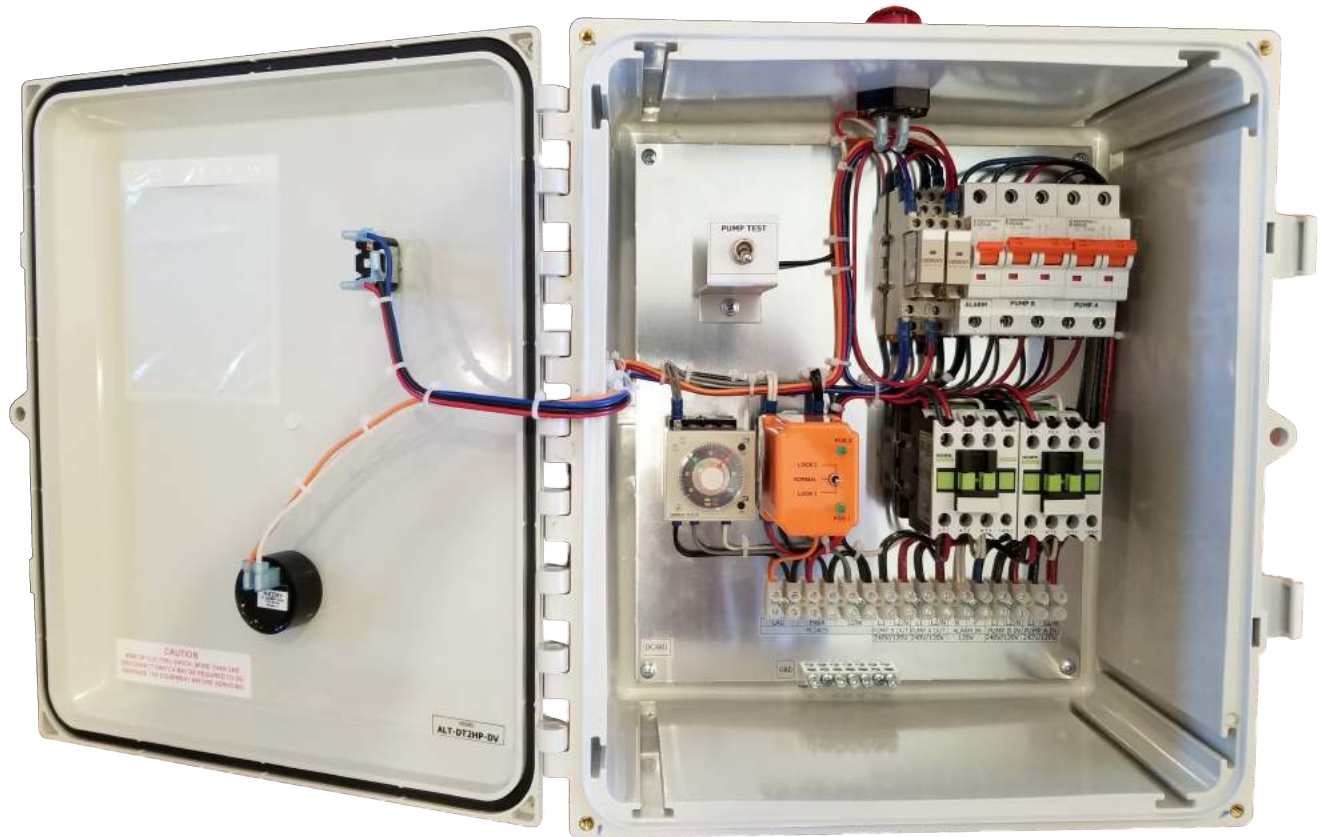

# Grinder Pump Duplex Dosing Timer Control Panel

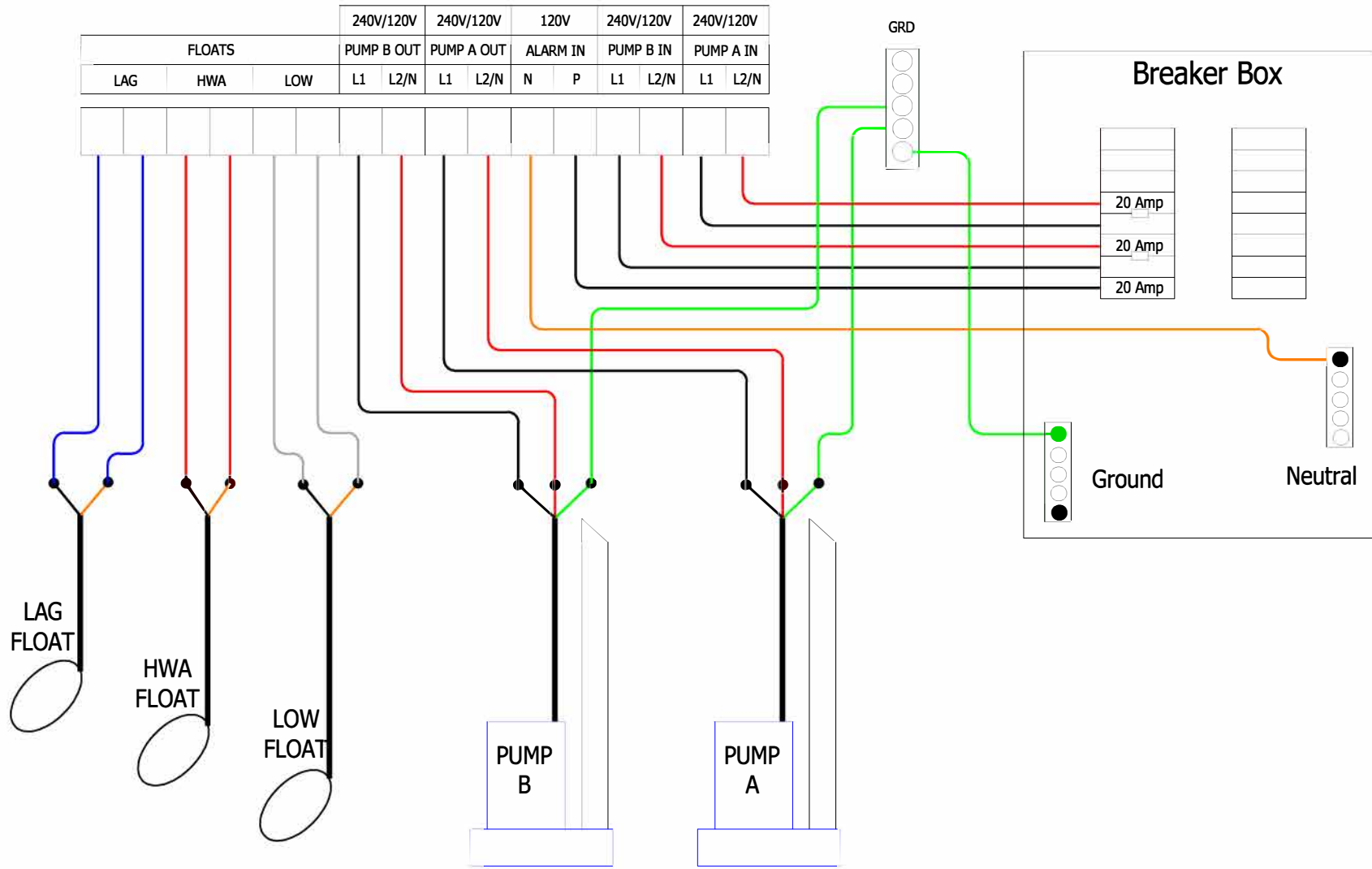

- Dual Voltage duplex lift station for 120 VAC or 240 VAC up to 2 HP.
- Pump operation will use an Omron H3CR dosing timer.
- Cross wired alternating relay with load lock switch for alternating pumps.
- Pump Test switch inside the enclosure.
- High water alarm will use a N/O float.
- Alarm Test and Silence switch in the door.
- Enclosure H x W x D = 14 x 12 x 6"



LAG  
FLOAT

HWA  
FLOAT

LOW  
FLOAT

PUMP  
B

PUMP  
A



TITLE				Grinder Pump Duplex Dosing Timer Control Panel Field Wiring	
SIZE	CAGE CODE	DWG NO	011619RW	REV	0
B					
SCALE		SHEET	1 of 1		