

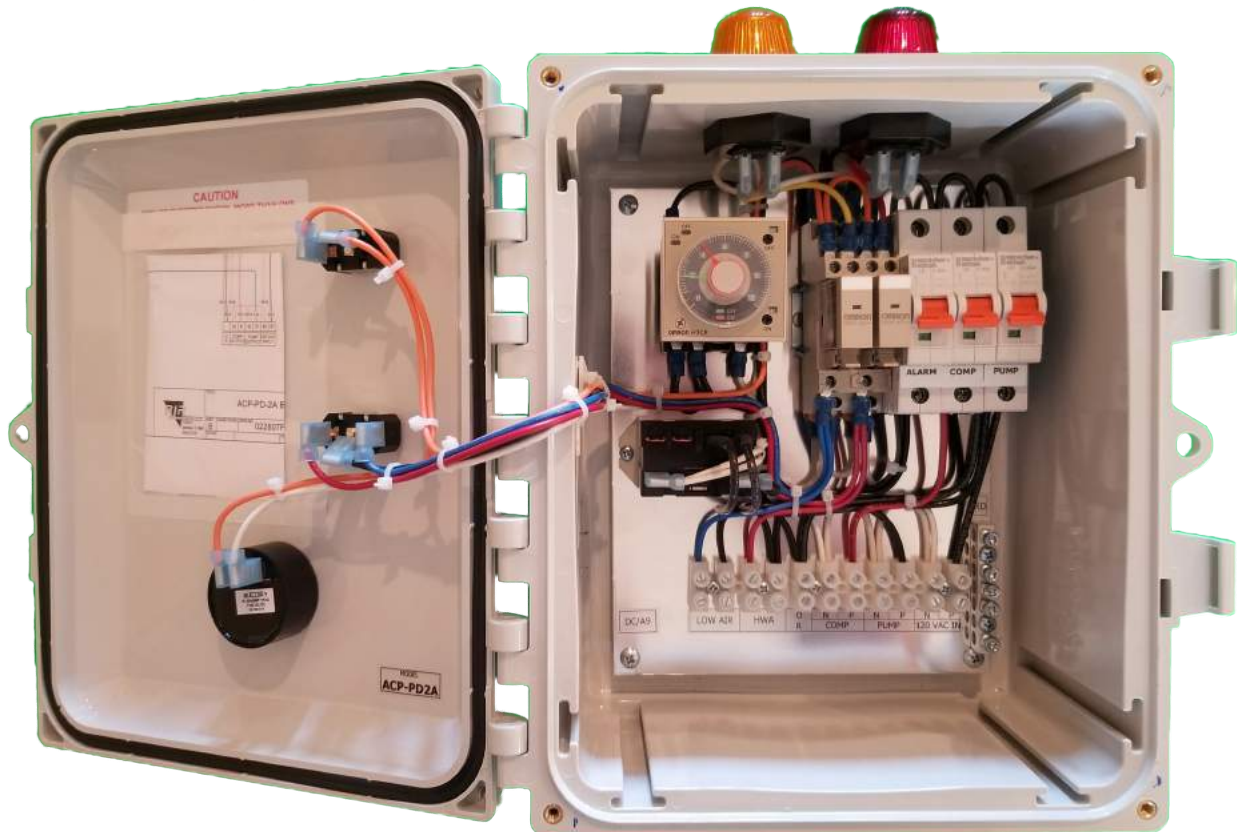

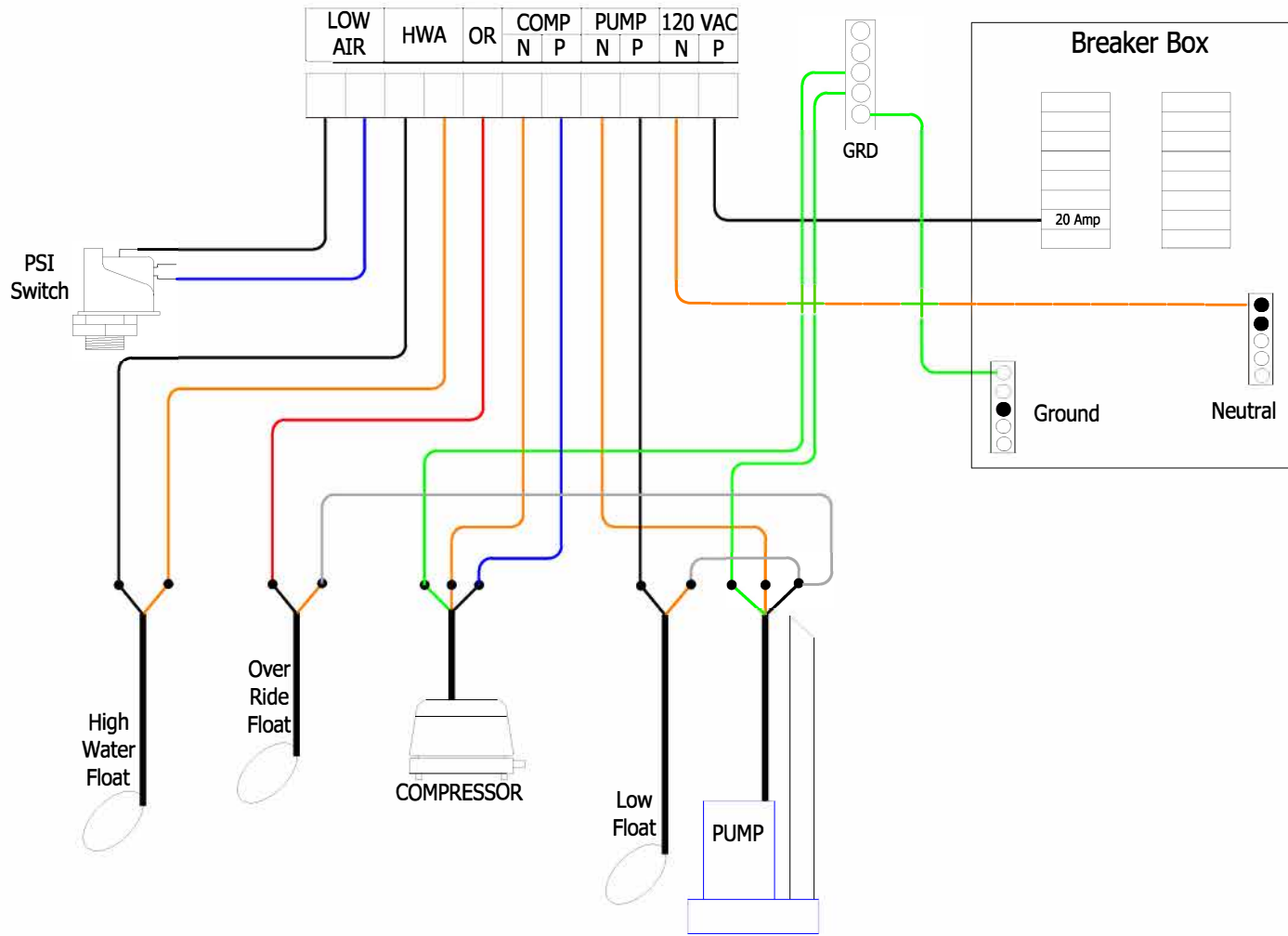

# Aerobic Dosing Timer Control Panel



- Aerobic treatment units with rotary or linear compressor.
- Aerator alarm will use included pressure switch.
- Pump operation will be from an Omron H3CR dosing timer.
- High water alarm and timer over ride will use a N/O float.
- Two Alarm: Amber-Low Air and Red-High Water
- Alarm Test and Silence switch in the door.
- Enclosure H x W x D = 10 x 8 x 4"



	TITLE			Aerobic Dosing Timer Control Panel	
				Field Wiring	
	SIZE	CAGE CODE	DWG NO	REV	
B		011619RW	0		
SCALE		SHEET	1 of 1		