

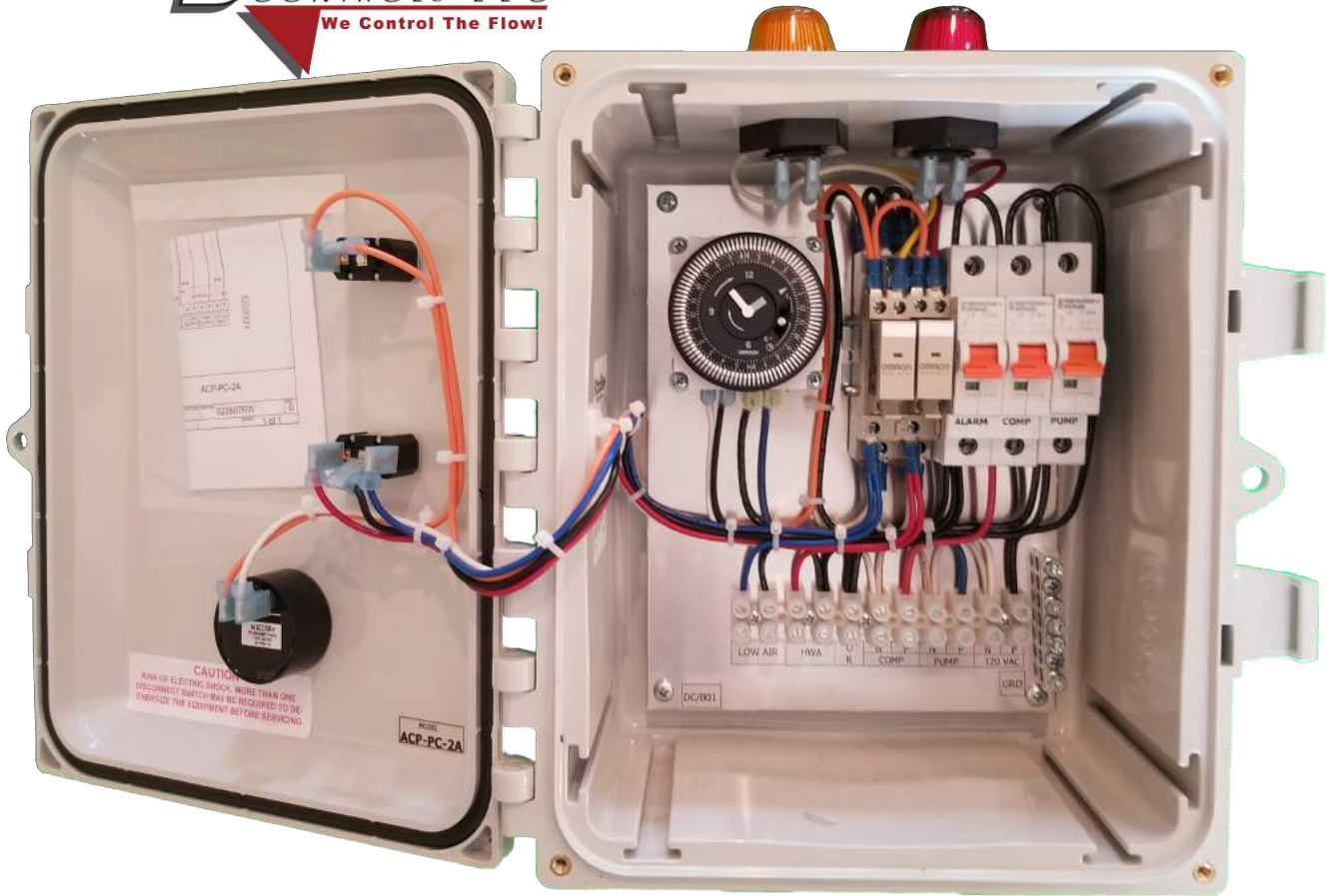

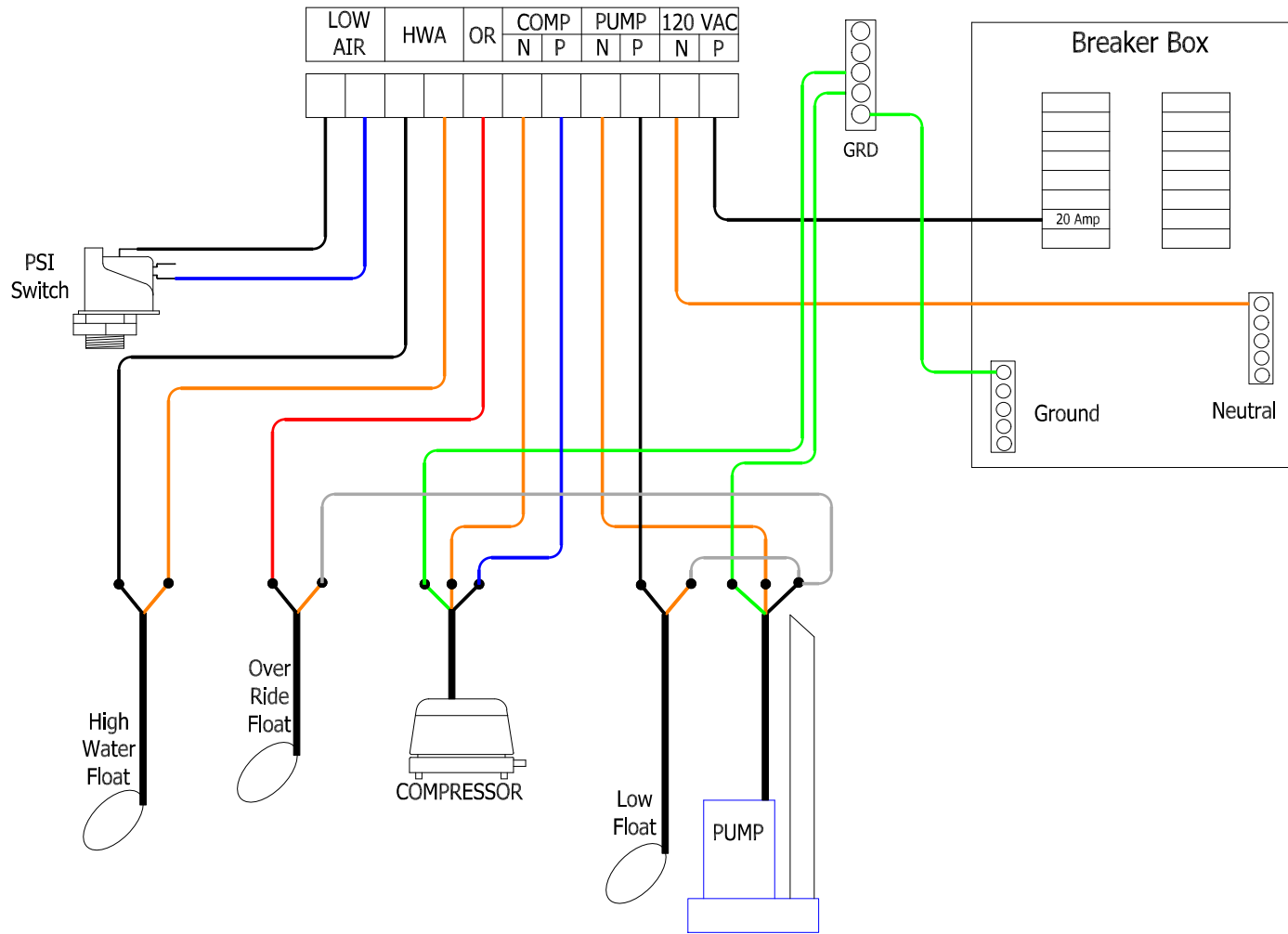

## ACP-PC-2A



- Aerobic treatment units with rotary or linear compressor.
- Aerator alarm will use included pressure switch.
- Pump operation will be from a 15 minute pin clock timer.
- High water alarm and timer over ride will use a N/O float.
- Two Alarm: Amber-Low Air and Red-High Water
- Alarm Test and Silence switch in the door.
- Enclosure H x W x D = 10 x 8 x 4"



		TITLE		ACP-PC-2A Field Wiring	
		SIZE B	CAGE CODE	DWG NO 011619RW	REV 0
SCALE		SHEET		1 of 1	