

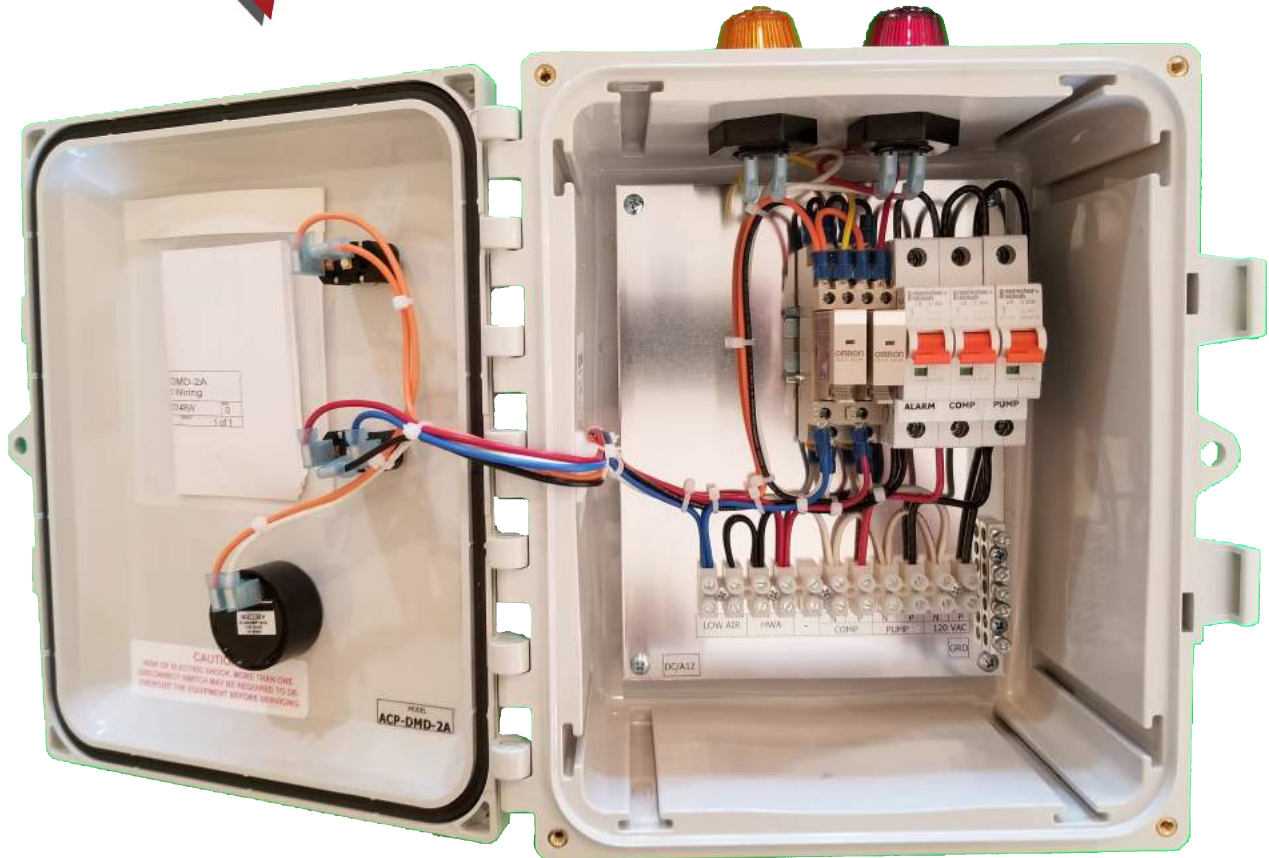

Aerobic Septic Control Panel Dual Light

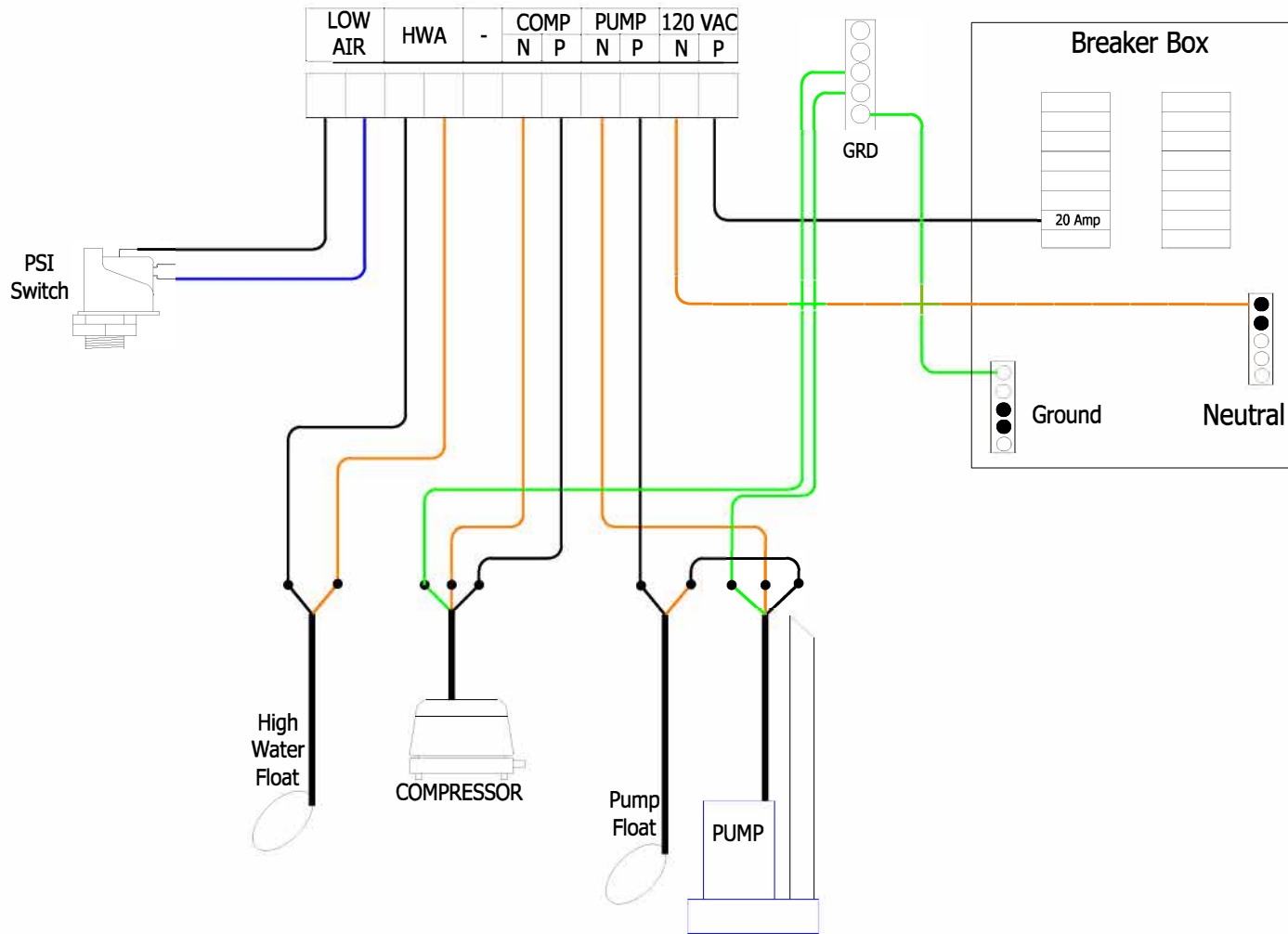

- Aerobic treatment units with rotary or linear compressor.
- Aerator alarm will use included pressure switch.
- Pump operation will be on demand.
- High water alarm will use a N/O float.
- Two Alarm: Amber-Low Air and Red-High Water
- Alarm Test and Silence switch in the door.
- Enclosure H x W x D = 10 x 8 x 4"



	TITLE Aerobic Septic Control Panel Dual Light Field Wiring			
	SIZE B	CAGE CODE	DWG NO 011619RW	REV 0
	SCALE		SHEET	1 of 1