

# FujiMAC 80r2

## Product Details:

- Linear Diaphragm air pump
- Quiet Operation
- Oil free operation
- Thermal over load protection
- Easy maintenance



Rated Voltage	120	Volts
Power supply Frequency	60	Hz
Power Consumption	51	W
Suggested Pressure Range	1.75-2.6	PSI
Normal Pressure	2.2	PSI
Airflow at Rated Pressure	80	L / min
	2.8	cfm
Sound level	39	dB
Weight	11	lbs.
Length	8 1/8	In
Width	6 3/8	In
Height	7 1/2	In
Outlet Outer Diameter	3/4	In
Outlet Inner Diameter	1/2	In



## DIMENSIONS

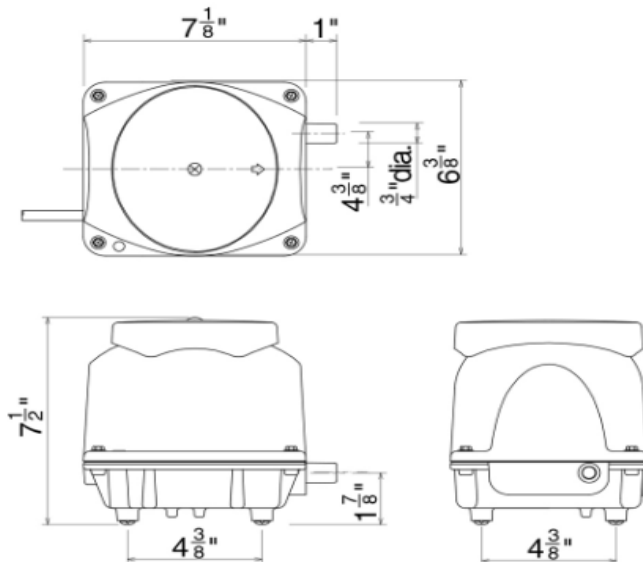

## PERFORMANCE CURVE

