

HP-60A ALARM UNIT

Product Details:

- Integral low-pressure alarm
- Standard UL approved 120 VAC models
- Pumps equipped with thermal overload protection.



Max Flow (lpm)	60
Max Cont. Operating Max Pressure (PSI)	2.13
Power Consumption (watts)	51
Noise Level (dBa @ 1m.)	35
Weight (lb)	16.3

DIMENSIONS

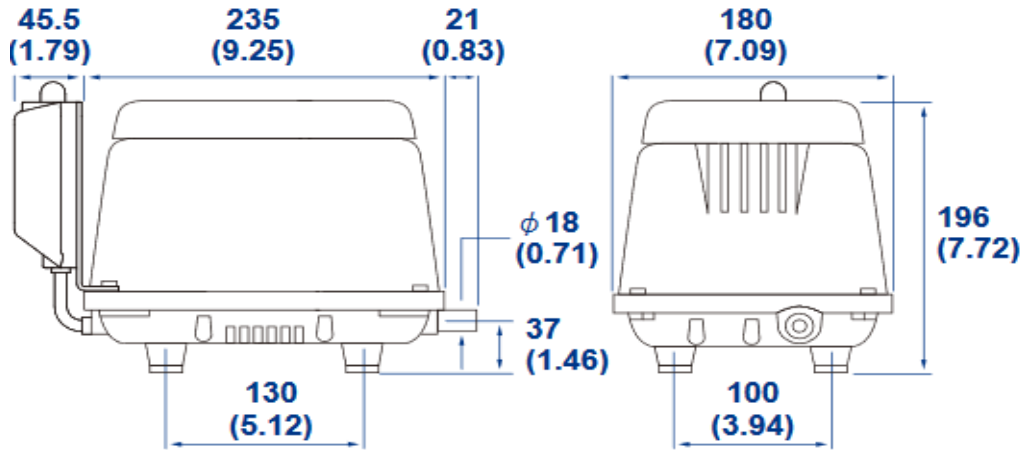

PERFORMANCE CURVES

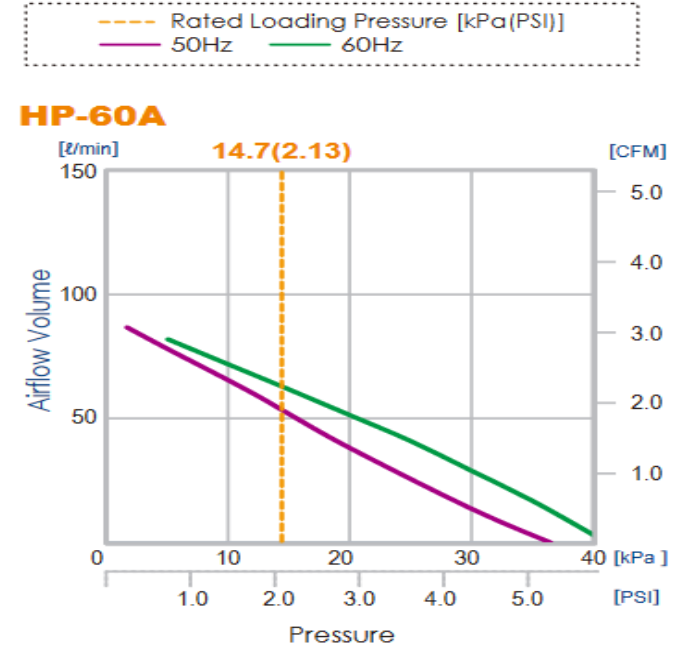

SPECIFICATIONS FOR HIBLOW HP-60A UNIT

- 3.5 cfm (cubic feet per minute) Maximum Air Flow (@ 0 PSI)
- 60 LPM (Liters Per Minute) @ 2.13 PSI
- 3.6 PSI Maximum Continuous Operating Pressure
- 120 VAC, 60 Hz, 1.3 A, 51 Watts
- 35 dBA Measured @ 1 meter
- Includes Attached Alarm to Signal Air Pump Failure
- Alarm Includes Run/Test/Mute Switch
- Dimensions: 9.3" L x 7.1" W x 7.8" H
- Condition: NEW
- Includes Rubber 90 with Hose Clamps

