

HP-40A ALARM UNIT

Product Details:

- Integral low-pressure alarm
- Standard UL approved 120 VAC models
- Pumps equipped with thermal overload protection.



Max Flow (lpm)	40
Max Cont. Operating Max Pressure (PSI)	1.9
Power Consumption (watts)	38
Noise Level (dBa @ 1m.)	32
Weight (lb)	13.4

DIMENSIONS

[Unit: mm(inch)]

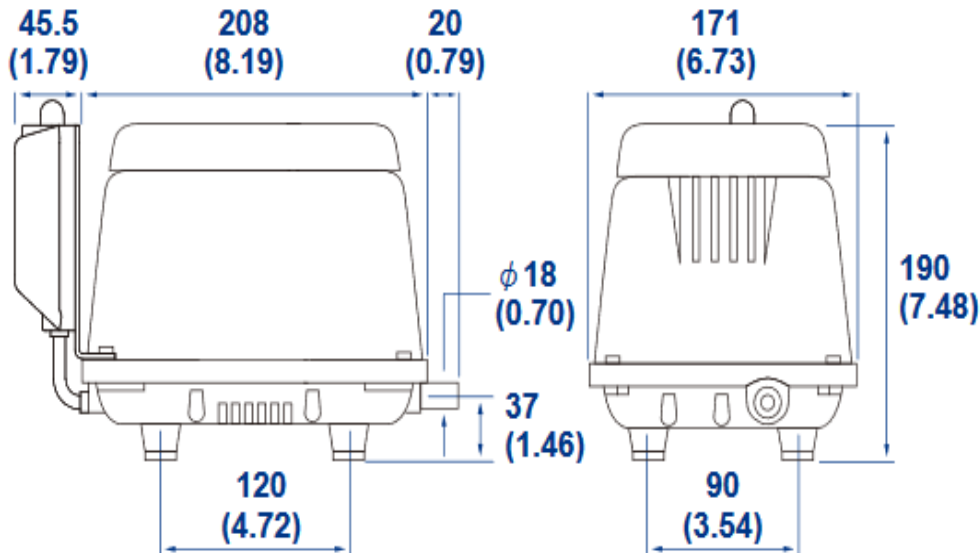

PERFORMANCE CURVES

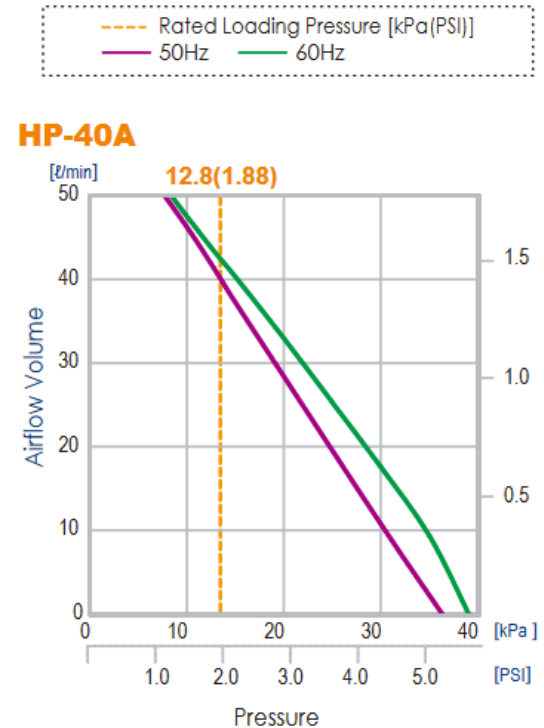

SPECIFICATIONS FOR HIBLOW HP-40A UNIT

- 2.8 cfm (cubic feet per minute) Maximum Air Flow (@ 0 PSI)
- 40 LPM (Liters Per Minute) @ 1.42 PSI
- 2.9 PSI Maximum Continuous Operating Pressure
- 120 VAC, 60Hz, 0.8 A, 38 Watts
- 32 dBA measured @ 1 meter
- Includes Attached Alarm to Signal Air Pump Failure
- Alarm Includes Run/Test/Mute Toggle Switch
- Dimensions: 8.2" L x 6.75" W x 7.5" H
- Condition: NEW
- Includes Rubber 90 with Hose Clamps
- Includes 1/8" Alarm Connection Fitting

