

FujiMAC 200R2

Product Details:

- Linear Diaphragm air pump
- Quiet Operation
- Oil free operation
- Thermal over load protection
- Easy Maintenance



Rated Voltage	120	Volts
Power supply Frequency	60	Hz
Power Consumption	155	W
Suggested Pressure Range	2.2-3.5	PSI
Normal Pressure	2.9	PSI
Airflow at Rated Pressure	200	L / min
	7.1	cfm
Sound level	43	dB
Weight	20	lbs.
Length	12 7/8	In
Width	7 1/8	In
Height	7 7/8	In
Outlet Outer Diameter	1	In
Outlet Inner Diameter	3/8	In



DIMENSIONS

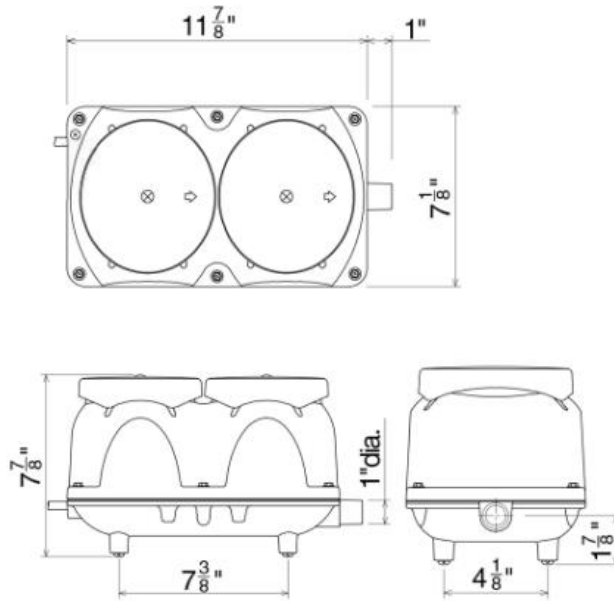

PERFORMANCE CURVE

