

GAST 1023-101Q-G608NEX

Product details:

- Rotary Vane style air compressor
- Low air pulsation
- Low maintenance
- Thermal overload protection
- Oil free operation
- Heavy duty
- One-year warranty



Rated Voltage	Volts	115
Power supply Frequency	Hz	60
Current	Amps	9.2
Power	W (hp)	560 (3/4)
Rotations Per Minute	RPM	1725
Maximum Pressure	PSI	10
Maximum Airflow	L / min	280
	cfm	10
Sound level	dB(A)	Less than 70
Temperature Range	°F	33.8 - 104
Weight	lbs.	47
Length	In	16
Width	In	6.5
Height (without filter)	In	8.6



DIMENSIONS

Inches

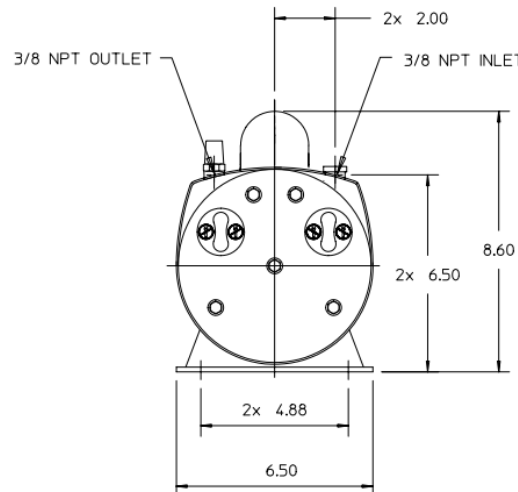
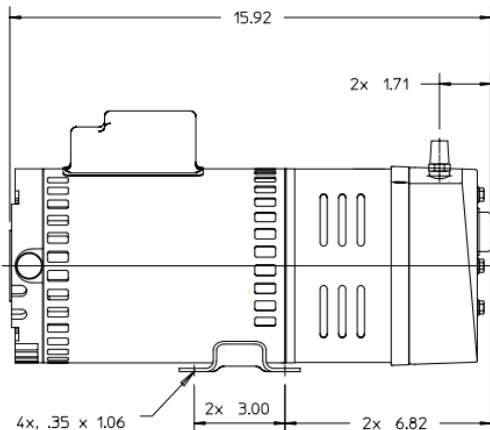

PERFORMANCE CURVE

