

Gast 0523-101Q-G588NDX

Product Details:

- Rotary Vane style air compressor
- Low air pulsation
- Low maintenance
- Thermal overload protection
- Oil free operation
- Heavy duty
- One-year warranty



Rated Voltage	V	120
Power supply Frequency	Hz	60
Power	W (hp)	190 (1/4)
Current	Amps	4.6
Maximum Airflow	L / min	127
	cfm	4.5
Noise Level	dB(A)	Less than 70
Weight	lbs.	32
Length	In	14.12
Width	In	5.63
Height (Without filter)	In	6.36



DIMENSIONS

PERFORMANCE CURVE

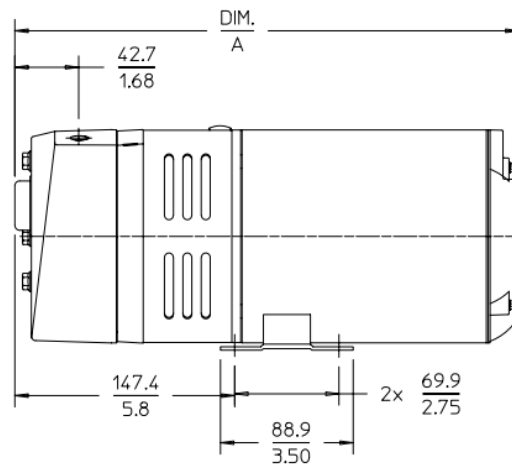
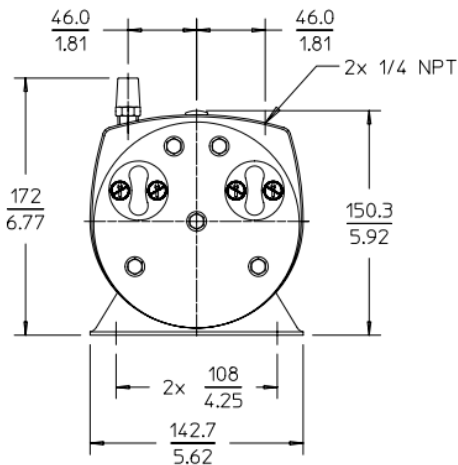

*Solid line for 60 Hz
 **Dashed line for 50 Hz

