



Building on quality

Portable screw
compressors



Reliable mobile compressed air solutions

C14 – C270TS-9

C55-14 to C76

⇒ 5.5 to 7.6 m³ / min

Product range DLT 0704

These proven and tested compressors stand out for their low fuel consumption and high efficiency. Thanks to a wide pressure range up to 14 bar, this compact compressor range is extremely versatile and meets many requirements of numerous applications. The compressors have enough storage capacity for two hammers, picks or any other pneumatic tools. Separate engine and compressor air filters guarantee a long service life. All of the service points are strategically located for easy access.

⇒ Cummins B3.3TAA

quiet-running and low vibration 4-cylinder diesel engine

⇒ Soft start

extends the engine life time by reducing engine stress during start-up and allowing the engine to reach running temperature with the compressor unloaded

⇒ Robust plastic protection

protects the control panel and lighting elements



⇒ Easy access hinged hood

with two robust gas struts, the hood is light and easy to open, offering excellent accessibility for easy maintenance

⇒ Bolted single sheets

The steel canopy is mass galvanised and electrostatically coated, offering excellent protection against damage and corrosion. With bolted single sheets, exchange is both quick and easy

⇒ Air filters

separate air filters for engine and air compressor

⇒ Fuel filter

fuel contamination is controlled by high quality filter which includes water separation. In addition to this every compressor has a manual fuel pump as standard

⇒ Progressive volume flow regulation

engine speed and air intake regulation are automatically adapted to compressed air requirement

⇒ Air end with spin-on oil filter cartridge

for quick and easy maintenance

⇒ Transparent plastic fuel tank

allows direct visual level indication and quick contamination checks

⇒ Central lifting eye

for easy handling by crane

⇒ Operational reliability

designed for -10 to +50°C ambient temperature

⇒ Oil temperature regulation valve

ensures safe operation of compressor at low ambient temperatures or extreme partial load

⇒ Internal main switch

avoids unauthorised operation

⇒ Filtration

according ZTV-ING part 3 section 4



Portable-Control 2

⇒ Fully protected digital display

with tamper proof hour counter

⇒ Automatic protection in case of malfunction:

- Compressor temperature too high
- Engine oil pressure too low
- Engine temperature too high
- Battery voltage too low
- Fuel level too low

⇒ Indication lamps

for automatic emergency stop in case of malfunction

⇒ Start by rotary switch

to avoid loss of time caused by lost ignition key

⇒ Internal main switch

avoids unauthorised operation

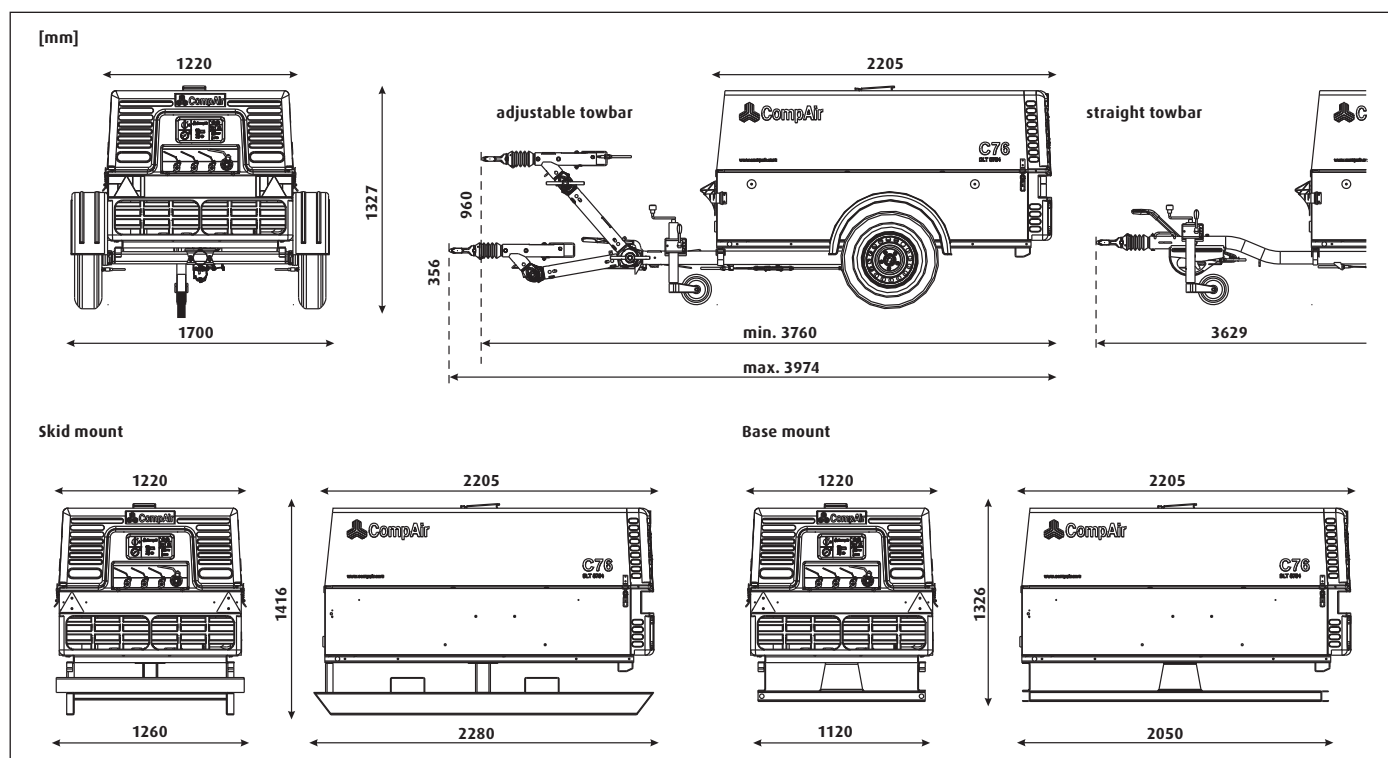

Product range		DLT 0704				
Type		C55-14	C60-12	C65-10	C65HS	C76
Operational data						
Volume flow ¹⁾ (Optional 9 or 15 kVA Generator)	m ³ /min	5.5	6.0	6.5	6.5	7.6
Operating pressure	bar	14	12	10	7	7
Compressed air outlet		3 x 3/4" + 1 x 1 1/2"				
Engine		Cummins B3.3 TAA				
Installed engine power	kW	63	63	63	63	63
Engine off load speed	1/min	1700	1700	1700	1700	1700
Engine full load speed	1/min	2600	2600	2600	2600	2600
Fuel tank capacity	l	140	140	140	140	140
Operating weight²⁾						
Portable compressor	adjustable towbar braked	kg	1200	1200	1200	1200
	straight towbar braked	kg	1160	1160	1160	1160
Base mount	kg	1070	1070	1070	1070	1070
Skid mount	kg	1100	1100	1100	1100	1100
Dimensions						
Length	adjustable towbar braked	mm	3760–3974	3760–3974	3760–3974	3760–3974
	straight towbar braked	mm	3629	3629	3629	3629
Width	mm	1700	1700	1700	1700	1700
Height	mm	1440	1440	1440	1440	1440
Length of the canopy	mm	2205	2205	2205	2205	2205
Sound level						
Power sound level ³⁾	dB(A) LWA	99	99	99	99	99
Pressure sound level ⁴⁾	dB(A) LPA	71	71	71	71	71

¹⁾ Acc. to ISO 1217 Ed. 4 2009 Annex D ²⁾ Operating weight without options ³⁾ Legal limiting values of EC directive acc. to 2000/14/EC

⁴⁾ Noise level acc. to PNEUROP PN8NTC.2.2 at 7 m

 Options on fold out page →