

ATTiny85 Arduino Pins:  
 IC Pin: Arduino Ref:  
 1 5/A0/RST  
 2 3/A3  
 3 4/A2  
 4 GND  
 5 0 - PWM  
 6 1 - PWM  
 7 2/A1  
 8 +Supply

ISP Connections:  
 1 - MISO  
 2 - Vcc  
 3 - SCK  
 4 - MOSI  
 5 - RESET  
 6 - GND

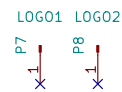
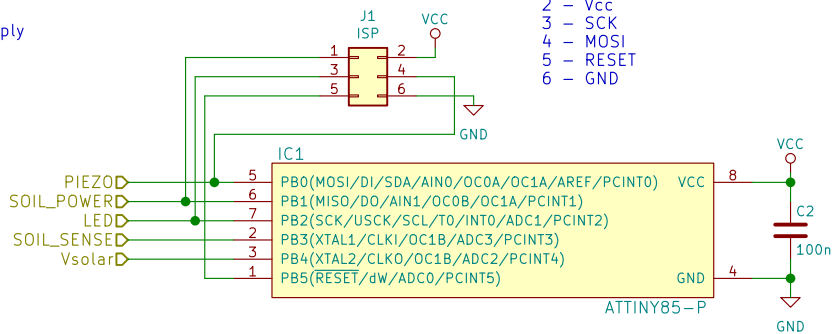

The Curious Electric Company

Sheet: /  
 File: SolarSoilSensor.sch

Title: Solar Soil Sensor

Size: A4 Date: 2020-07-09

KiCad E.D.A. kicad (5.1.0)-1

Rev: 1

Id: 1/1