



Date: 13/10/2023 Version: 6.2 By: Matt Little



### Build your own Bat Detector!

Bats use ultra-sonic pulses to navigate and to detect prey. These pulses are very high pitch (around 5 times the maximum frequency humans can hear).

This electronic circuit converts the high pitched sounds produced by bats to a human-audible level.

It has a sensitivity control to adjust for different conditions. This slightly updated version has a headphone output socket for stealth monitoring (sorry, headphones not included!).

It can also be used to listen to other high frequencies such as peeling sticky tape, compact fluorescent lights and power supplies.

*Note: This kit, although easy to build, requires quite a lot of soldering so will take in the region of 2-3 hours.*

### Parts included:

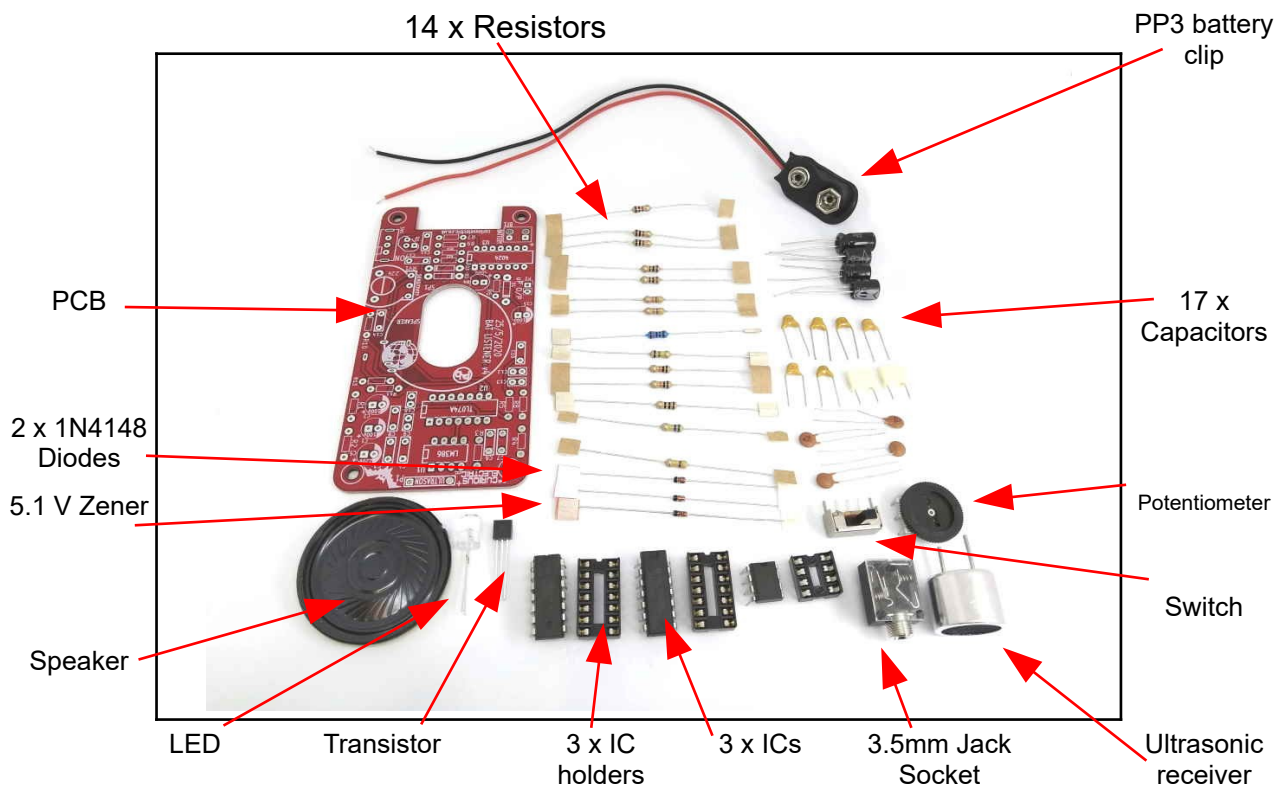

## Enclosure Parts:

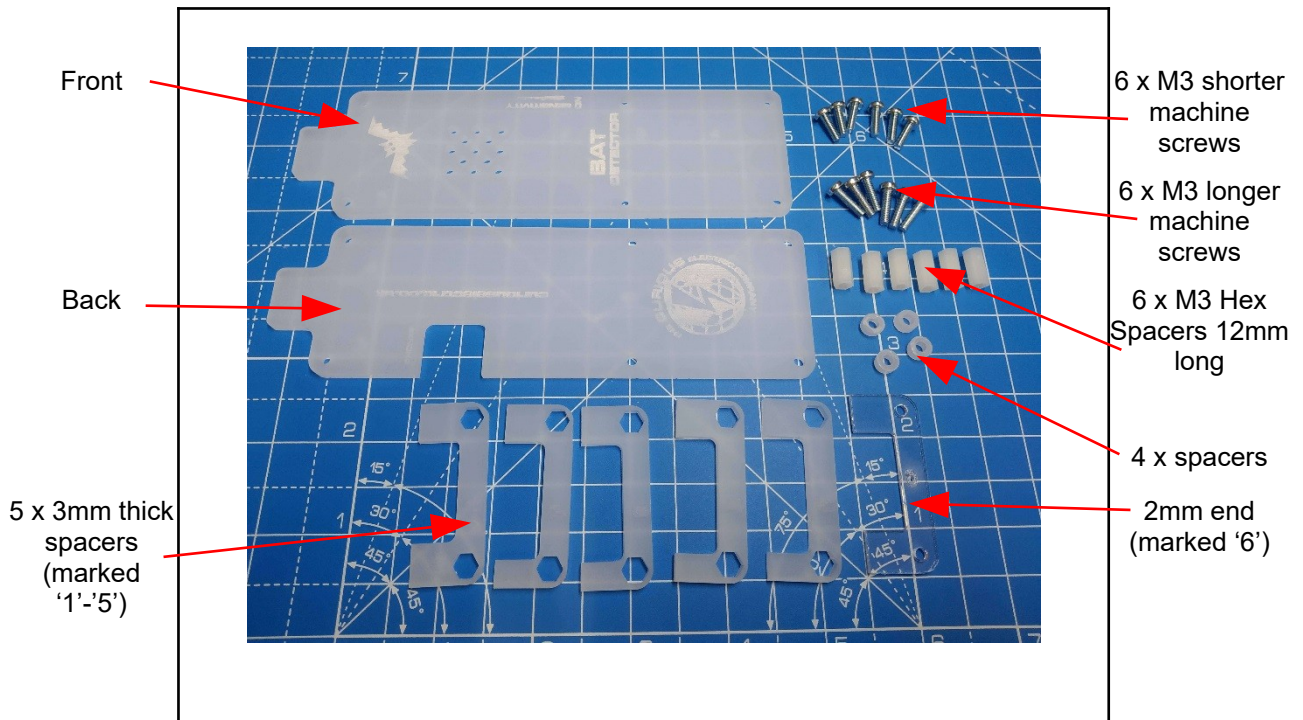

## Parts list:

<i>PCB and Electronics:</i>			
Item	Ref	Item	Ref
PP3 Battery Clip	BT1	47k Resistor	R1, R2
100uf Capacitor	C1, C2, C15	10 ohm Resistor	R3
220nf Capacitor	C3	1.3k Resistor	R4
47nf Capacitor	C4, C6	150k Resistor	R5
220uf Capacitor	C5	10k Resistor	R6, R12
2.2nf Capacitor	C7	1k Resistor	R7, R8, R14
1.5nf Capacitor	C8	470k Resistor	R9
100pf Capacitor	C9, C16	560k Resistor	R10
1nf Capacitor	C10	100 ohm Resistor	R11, R13
33nf Capacitor	C11, C17	20k Potentiometer	RV1
470pf Capacitor	C12, C13	40mm Loudspeaker	SP1
100nf Capacitor	C14	Switch	SW1
5.1V Zener Diode	D1	LM386 Audio Amplifier IC	U1
1N4148 small signal Diode	D2,D3	TL074 Quad-comparator IC	U2
5mm Red LED	D4	4024 Counter IC	U3
Ultrasonic Receiver	P1	3.5mm Headphone Jack Socket	J1
BC337 Transistor	Q1		

<i>Enclosure:</i>			
<b>Item</b>	<b>Ref</b>	<b>Item</b>	<b>Ref</b>
Front	x1	3mm PCB spacer rings	x4
Back	x1	M3 Hex spacers (12mm long)	x6
2mm clear plastic spacer (marked '6')	x1	M3 shorter (8mm or 10mm) machine screws	x6
3mm frosted plastic spacer (numbered '1' to '5')	x5	M3 longer (12mm) machine screws	x6

Tools required:



## PCB Instructions:

### Step: 1 Solder resistors

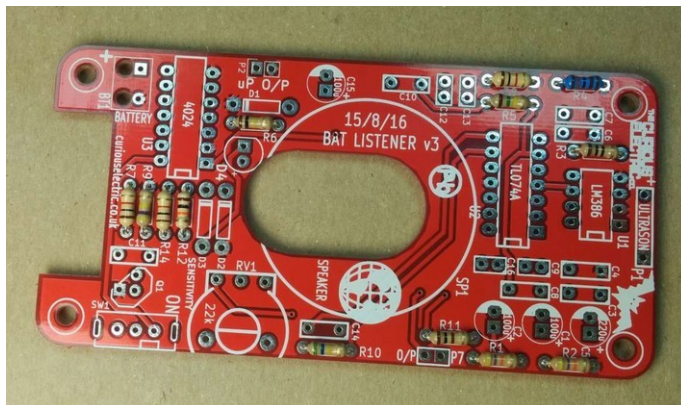
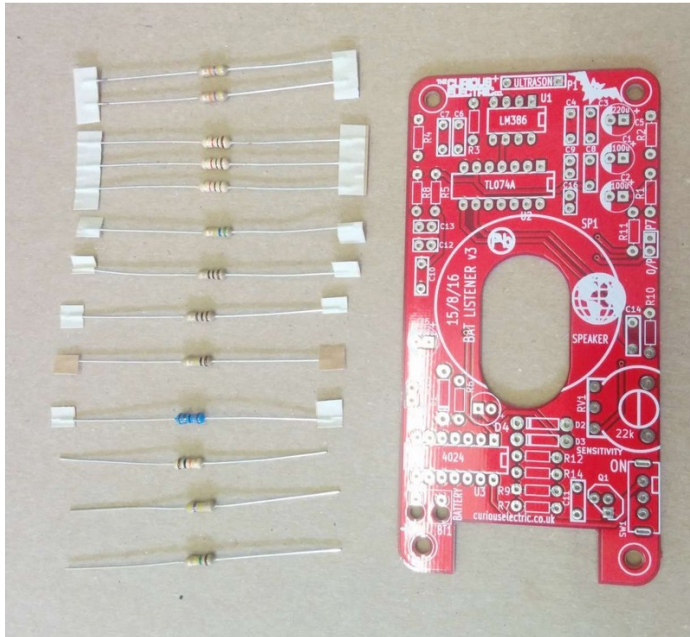

Value	Ref	Colour
47k	R1, R2	Yellow, Violet, Orange, Gold
10	R3	Brown, Black, Black, Gold
1.3k	R4	Brown, Orange, Black, Brown, Brown
150k	R5	Brown, Green, Yellow, Gold
10k	R6, R12	Brown, Black, Orange, Gold
1k	R7, R8, R14	Brown, Black, Red, Gold
470k	R9	Yellow, Violet, Yellow, gold
560k	R10	Green, Blue, Yellow, Gold
100	R11, R13	Brown, Black, Brown, Gold











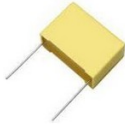

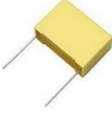
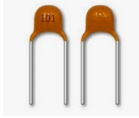
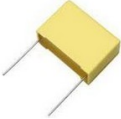
Insert and solder the resistors. Polarity does not matter for resistors. Ensure they are soldered flat close to the PCB.

*Note: Some resistors are blue – check the colour codes at the end of these instructions.*

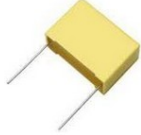
Use a multimeter or colour code chart to ensure correct resistor values.

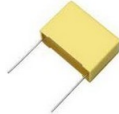
## Capacitor Information

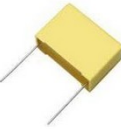
Due to changes in component suppliers your kit may have different styles of capacitors included.

Value	Ref	Marking	Image	Marking	Image
220nf	C3	'22K63'		'224'	
47nf	C4, C6	'47nK100'		'473'	
2.2nf	C7	'2n2K100'		'222'	
1.5nf	C8	'152'	Also in blue 		
100pf	C9, C16	'101'		'101'	
1nf	C10	'1nK100'		'102'	
33nf	C11, C17	'33nK100'	Also in dark grey 	'333'	
470pf	C12, C13	'471'		'471'	
100nf	C14	'1K63' or '1J63'		'104'	
100uf	C1, C2, C15	'10V 100uf'		Might have different voltages	
220uf	C5	'16V 220uf'		Might have different voltages	

**Step: 2** Solder capacitors

First solder the non-polarised capacitors. Orientation of these does not matter:

Value	Ref	Marking
220nf	C3	'224' (brown blob)
47nf	C4, C6	47nK100 (cream box)
2.2nf	C7	'222' (brown blob)
1.5nf	C8	152 (brown blob)
100pf	C9, C16	101 (brown disk)
1nf	C10	1nK100 (cream box)
33nf	C11, C17	'333' (brown blob or black box)
470pf	C12,C13	471 (brown disk)
100nf	C14	'104' (brown blob)

*Note: You may need a magnifying glass for reading the text on these capacitors.*

Next solder the polarised capacitors. Ensure correct orientation of these components. The negative lead is marked with a white strip. The positive lead is slightly longer than the negative. Align the positive lead with the + sign and the negative lead with the white PCB marking.

Value	Ref	Marking
100uf Capacitor	C1, C2, C15	'100uf'
220uf Capacitor	C5	'220uf'

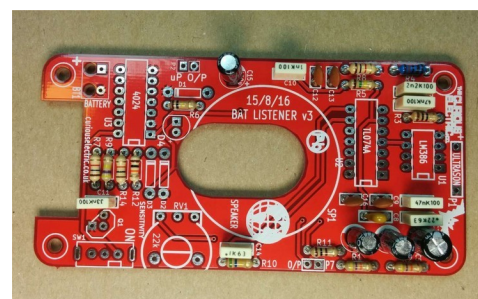
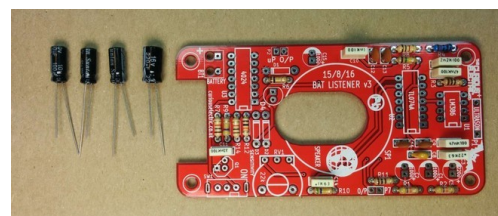
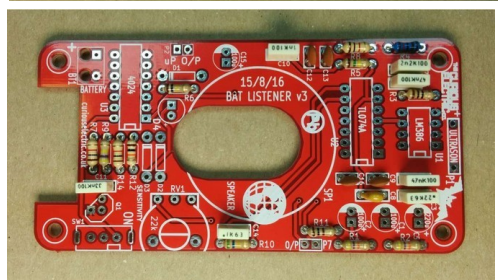
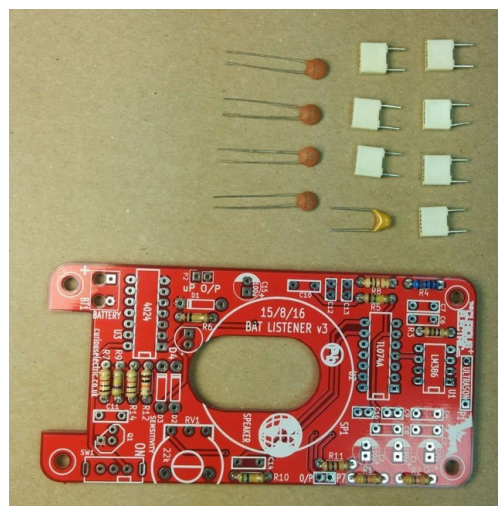

**Step: 3** Solder diodes

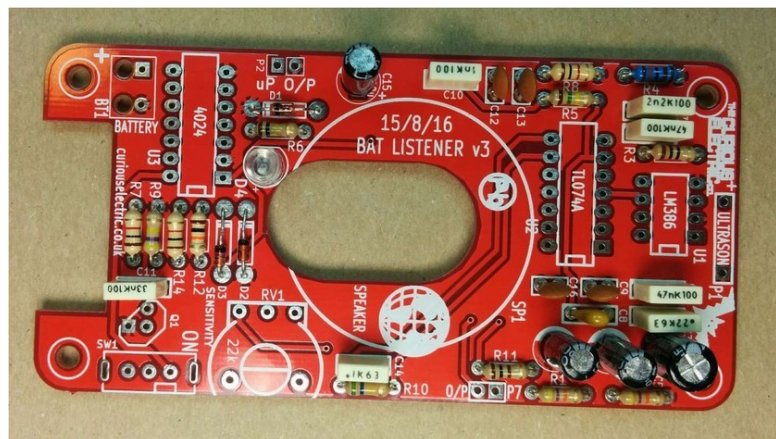
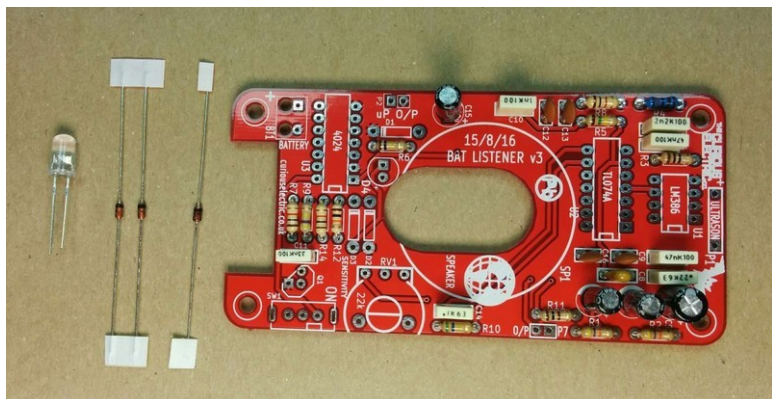

There are 4 diodes to solder. Ensure correct orientation for these components.

First solder the LED into D4. The long lead is positive, so place that into the hole marked +. The negative side is slightly flat.

Then solder the 5.1 V zener diode into D1. This diode is on it's own and has very tiny marking of "5V1". Ensure the black band aligns with the white band marked on the PCB.

Then solder the remaining 2 diodes into D2 and D3. These have tiny markings saying "4148". Ensure the black band aligns with the white band marked on the PCB.

**Step: 4** Solder transistor

There is just one transistor to solder, Q1, BC337. Ensure the flat side of the transistor aligns with the PCB markings.

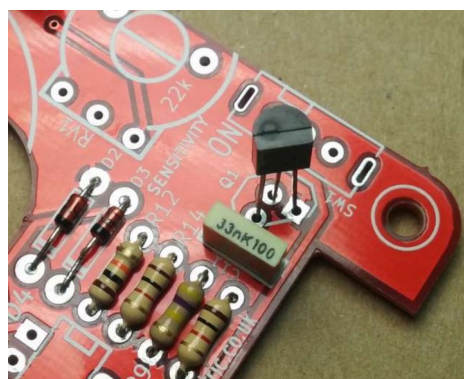
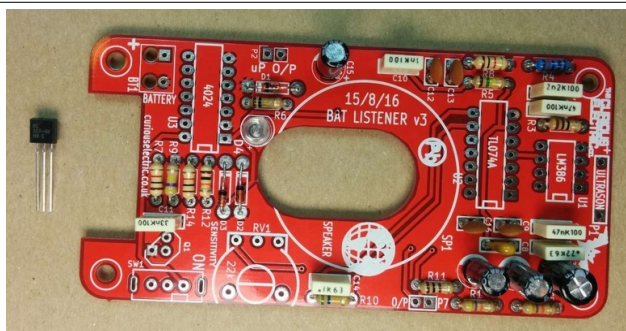

**Step: 5** Solder IC holders

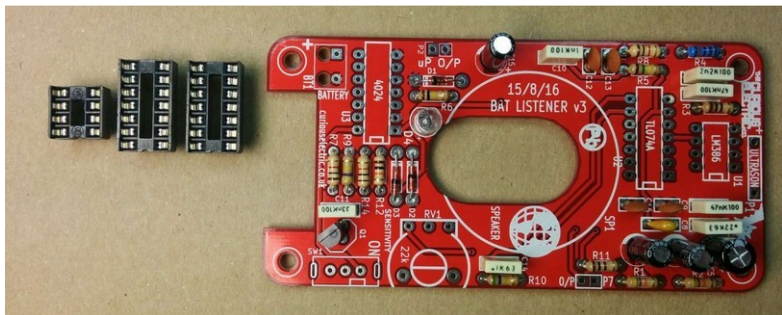

There are two 14 pin IC holders and one 8 pin IC holder. These fit into the areas marked U1, U2 and U3.

Ensure correct orientation!

Ensure the notch on the holder aligns with the notch shown on the PCB.

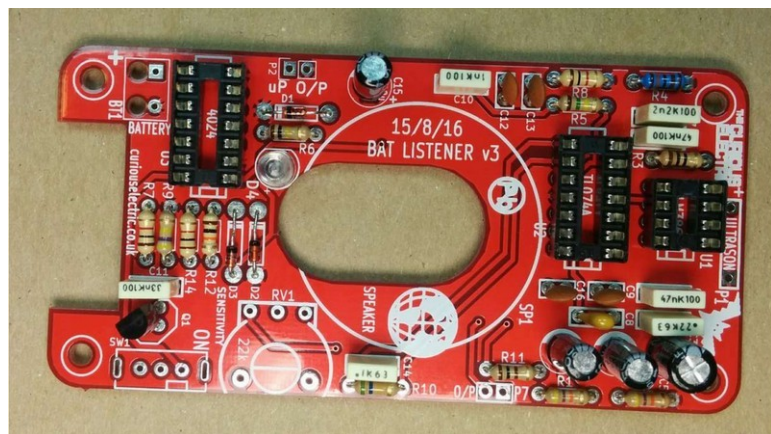

**Step: 6** Solder Switch and Potentiometer

The switch fits into the holes marked SW1. The switch knob goes off the PCB. Solder all metal tabs.

The potentiometer fits into the holes marked RV1. There are 5 pins to align and the pins might need slightly moving to ensure they align correctly.

Solder all metal tabs.

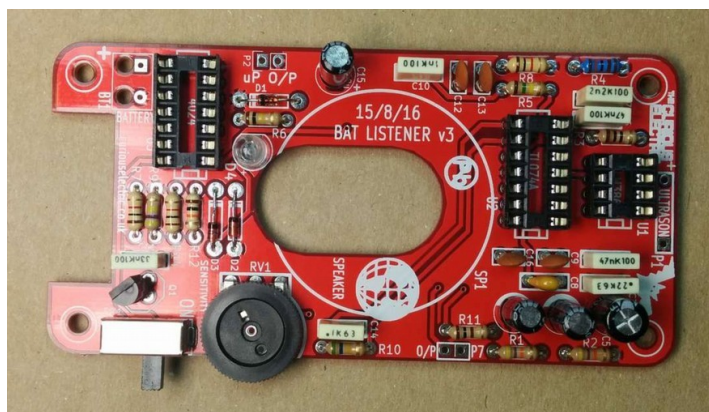
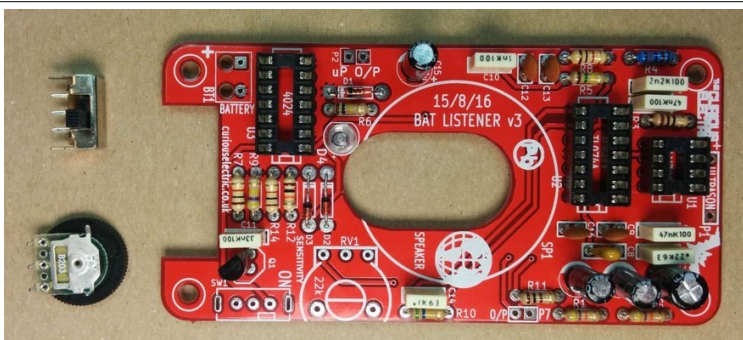



**Step: 7** Solder the ultrasonic receiver

The ultrasonic receiver has two pins, one is attached to the metal case of the unit, the other has a small ring around it.

Carefully bend the legs to 90 degrees to the receiver is facing away from the PCB. This is best done with a pair of pliers about 1/2 way up the legs of the receiver.

The pin with the small ring around it is the +ve connection and this pin fits in the hole with the + symbol. The ground fits next to the indicator P1.

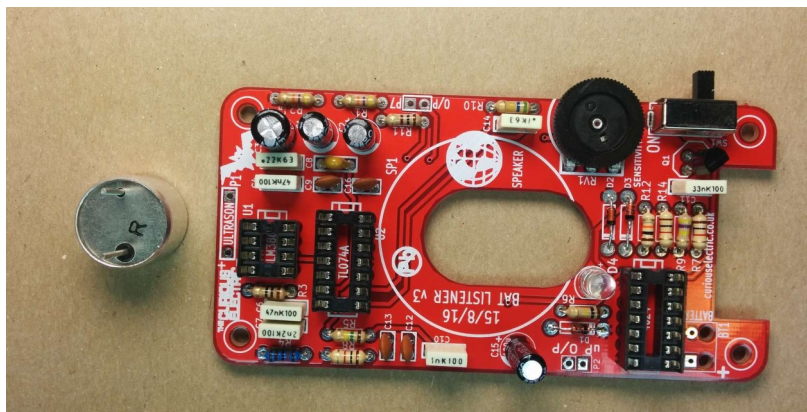
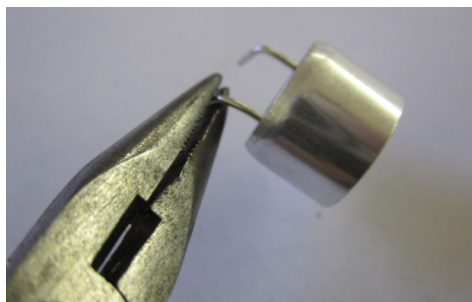

**Step: 8** Solder the headphone socket

The 3.5mm headphone jack socket is soldered on the back of the PCB. This must be soldered before the speaker. Insert from the underside into 'J1' and solder from the top side of the PCB.



**Step: 9** Solder Speaker

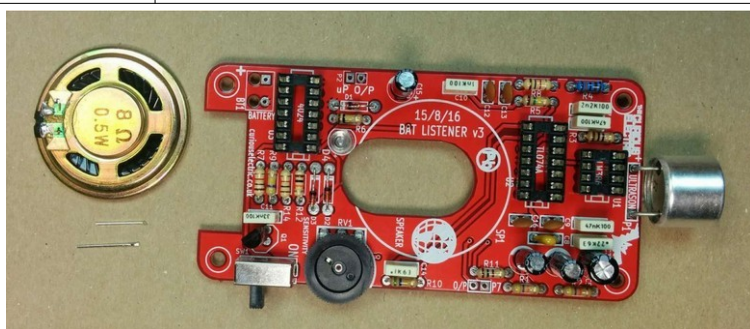

The speaker has a slightly unusual mounting method.

The speaker base fits through the large hole in the PCB and the speaker tabs align with the PCB tabs.

Use an off-cut of resistor lead and solder two small leads from the PCB (as shown). Carefully bend the legs to 90 degrees before soldering in position facing away



from the PCB.

Then put the speaker in place and solder the small wires to the speaker.

This method holds the speaker in place, as well as being the electrical connection.

A dab of hot-melt glue or epoxy can help hold the speaker in position, but make sure you don't get any on the black speaker cone.

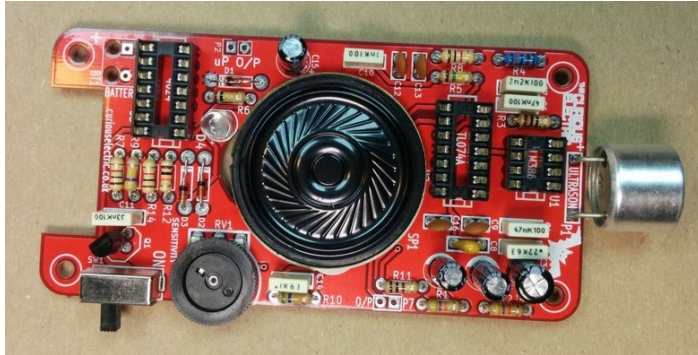

**Step: 10** Solder PP3 battery connector

Nearly there!  
The PP3 battery clip as two wires: one positive (red) and one negative (black).

I usually put a knot in the cable for strain relief.

The cables then go through the larger holes from the underside and are fed back into the solder pads.

The red cable goes through the hole to the pad marked "+".

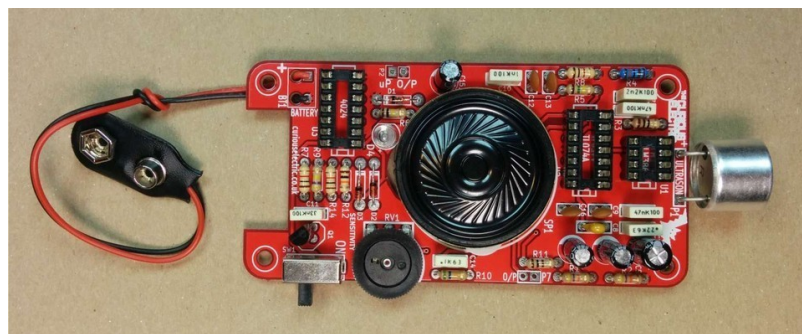
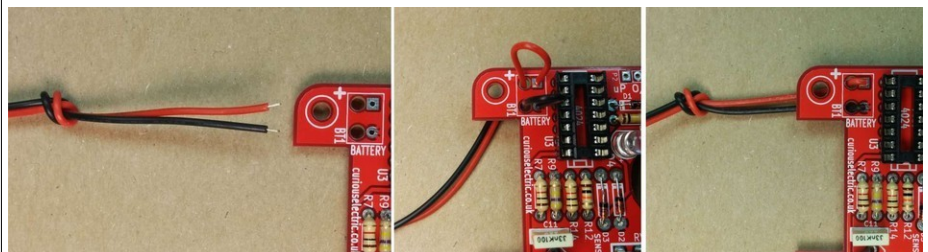
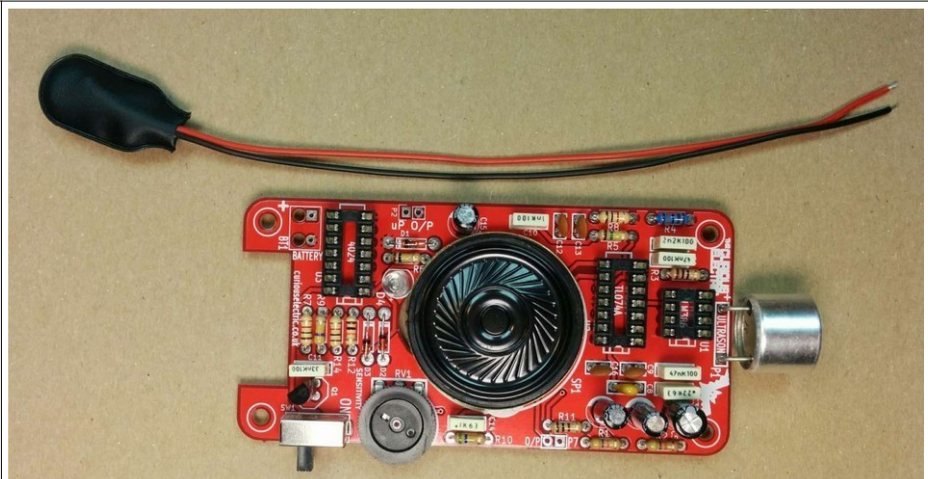

**Step: 11** Insert ICs

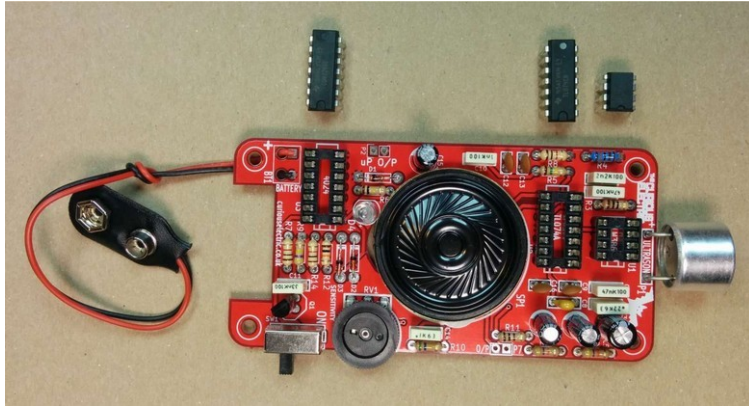

Now we need to insert the ICs into their holders. Ensure the notches align with the notches on the IC holders and the PCB.

U1 is the LM386 (8 pin)  
U2 is the TL074 (14 pin)  
U3 is the 4024 (14 pin)

**Step: 12** Insert battery and test

Add a PP3 9V battery to the battery clip. Switch the unit on. You may hear a squeal from the device. Adjust the potentiometer until you just do not hear any noise.

The red LED should also flash when the speaker clicks.

Use a reel of sticky tape to test. Slowly peel the tape off the reel and you should hear crackles from the speaker. This is picking up high frequency sound from the glue breaking. You can also test by pointing at a compact fluorescent light bulb. These switch at around 100 kHz and hence give off ultrasonic noise.

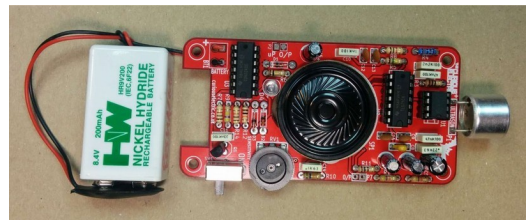

**Step: 13** PCB is finished!

Have a nice cup of tea.



## Enclosure Instructions:

**Step: 1** Push out laser-cut parts and peel off protective layer

Sometimes not all the small laser-cut pieces have been removed. These can be pushed out using the point of a screwdriver. Only slight force should be required.



There is a protective film on one side of ALL the laser cut plastic parts. This can be removed by peeling off the film.

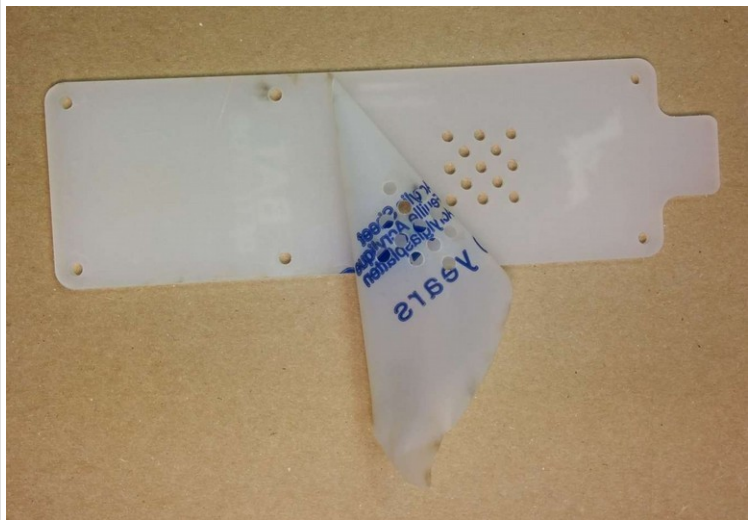

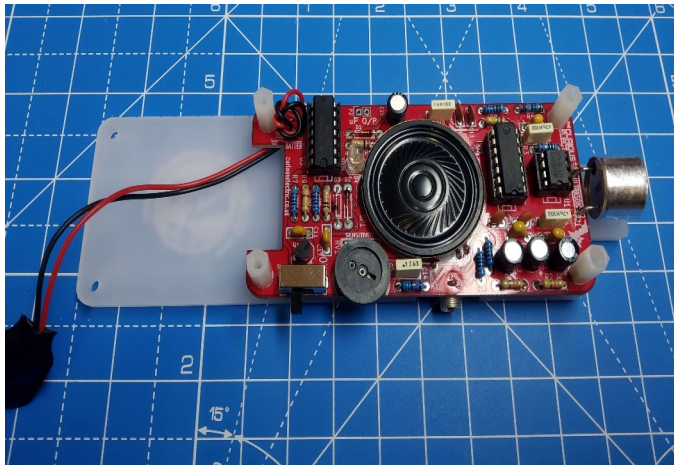
**Step: 2****Screw down the PCB**

The PCB is held onto the back plate using 4 of the M3 longer (12mm) screws and the hex spacers.

The back plate has the text facing to the back.

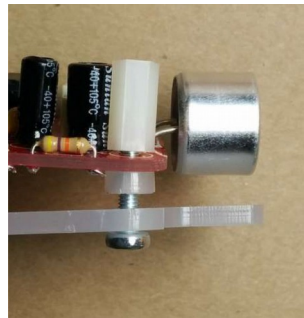

The screws fit through the back plate then through a small circular spacer ring and then through the PCB.

It is then held in place using the threaded hex spacer.

Do this for all four corners of the PCB.

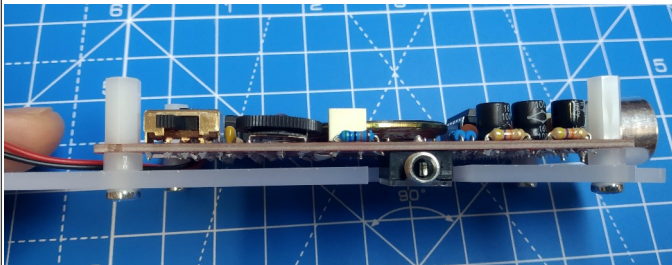

*Note: The headphone socket should align with the cut-out of the plastic base.*

**Step: 3** Add end spacers

To hold the end spacers in place we again use the longer 12mm screws and 2 of the hex spacers.

Put them through the back plate and slightly screw the hex spacer onto the screw.

Do not fully tighten this, as it will need to spin to be adjusted in the next step.

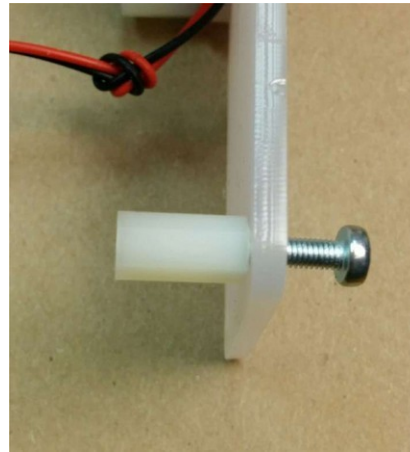
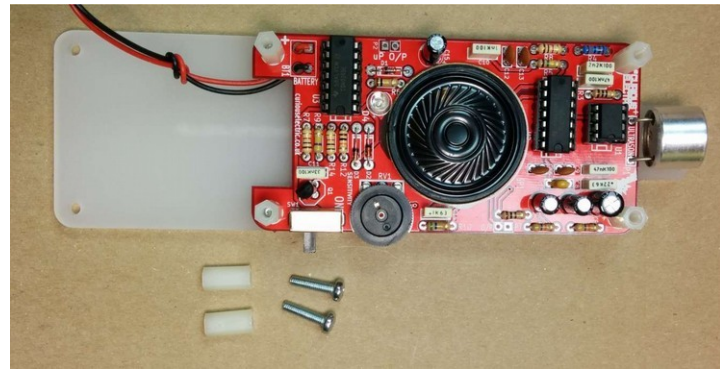

**Step: 4** Add battery holders



SIDE VIEW



The battery holders are 6 spacers which holds one end of the battery, with the other end being held the notch in the PCB.

There are three types of spacer:  
1 x narrow 3mm spacer (in white frosted plastic, marked "1")  
4 x wide 3mm spacers (marked "2", "3", "4" & "5").  
1 x narrow 2mm spacer in clear plastic (marked "6").

These fit onto the hex spacers we added in step .

First add the narrow 3mm piece (marked "1").

Then the 4 wide 3mm pieces (marked "2", "3", "4" & "5").



Put the battery into the enclosure. The PP3 battery clip fits within the wider section, with the cable able to come out of the side.

The final narrow 2mm spacer (marked "6") is put on top.

**Step: 5** | Fit top cover

The front cover is then put on with the text facing upwards. Use the 6 shorter (8mm/10mm) M3 machine screws to hold the front cover in place to the PCB holes and to hold the end spacers in place.

These fasten into the threaded hex spacers.

Tighten the 6 screws on the top, then you may also need to tighten the 6 screws on the bottom until fully secure.

**Note:** The LED can be seen through the frosted plastic.



**Step: 6** | Finished!



That is the unit finished!

The on/off switch and the potentiometer are accessible via the side of the unit.

You now have your own bat detector.

There are many things you can investigate including:

**Nature:** monitor bats, mice and rats

**Electrical:** Check the sound from switching power supplies and fluorescent lights

**Please note:** This unit is NOT waterproof. Do NOT leave outside if it will get wet.

## Contact details:

We would like you to be happy with this kit. If you are not happy for any reason then please contact us and we will help to sort it out.

Please email [hello@curiouselectric.co.uk](mailto:hello@curiouselectric.co.uk) with any questions or comments.

Please tweet us at [@curiouselectric](https://twitter.com/curiouselectric)

If any parts are missing from your kit then please email [hello@curiouselectric.co.uk](mailto:hello@curiouselectric.co.uk) with details and, if possible, when and where the kit was purchased.

More technical information can be found via [www.curiouselectric.co.uk](http://www.curiouselectric.co.uk)

This kit has been designed and produced by:

**The Curious Electric Company**

[hello@curiouselectric.co.uk](mailto:hello@curiouselectric.co.uk)

[www.curiouselectric.co.uk](http://www.curiouselectric.co.uk)

## History

This kit is based upon a circuit originally published by Elektor Electronics:

<https://www.elektormagazine.com/magazine/elektor-201111/19754>

and was originally developed as a workshop for Nottingham Hackspace:

[www.nottinghack.co.uk](http://www.nottinghack.co.uk)



# Circuit Schematic

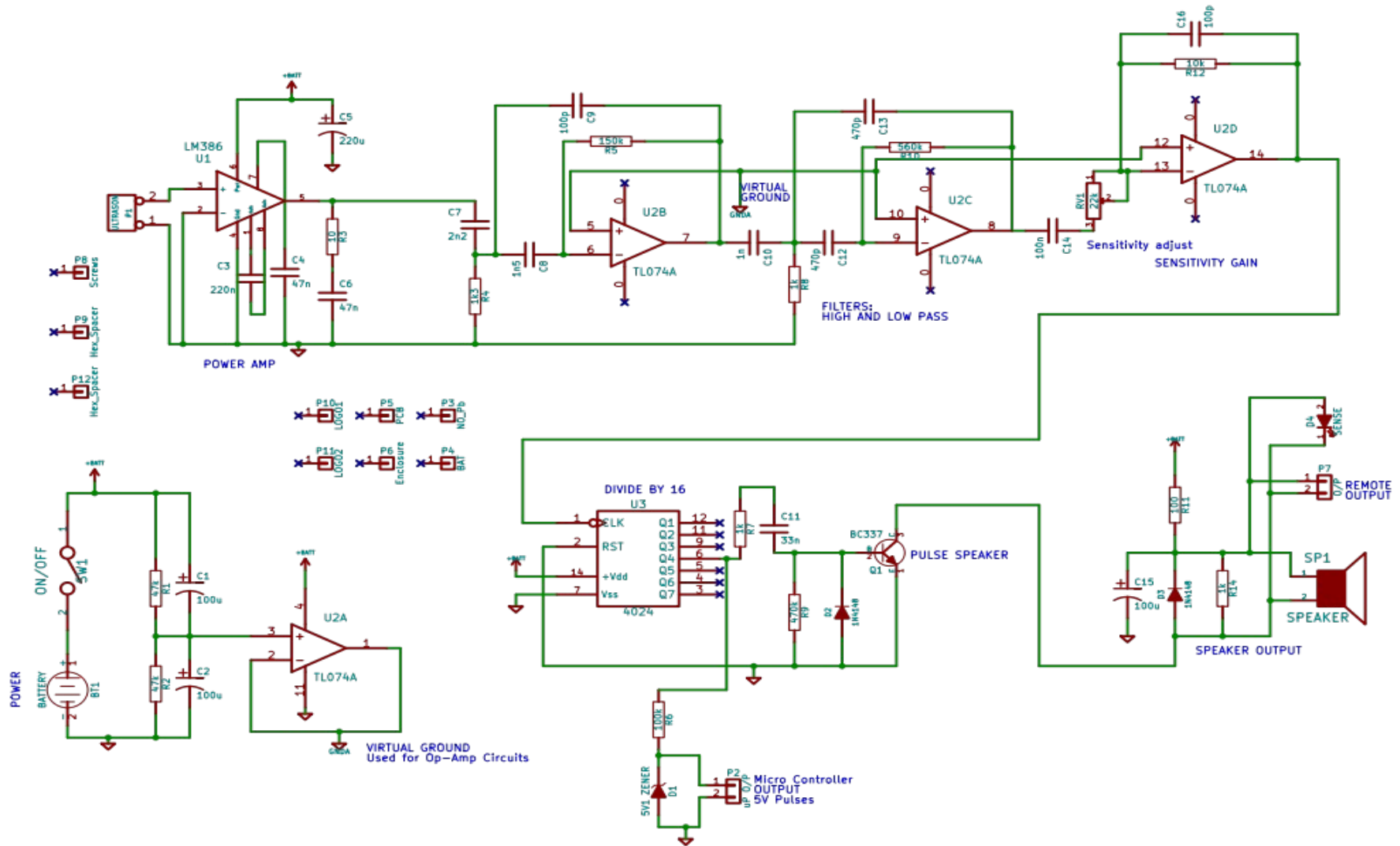

# Resistor Colour Codes

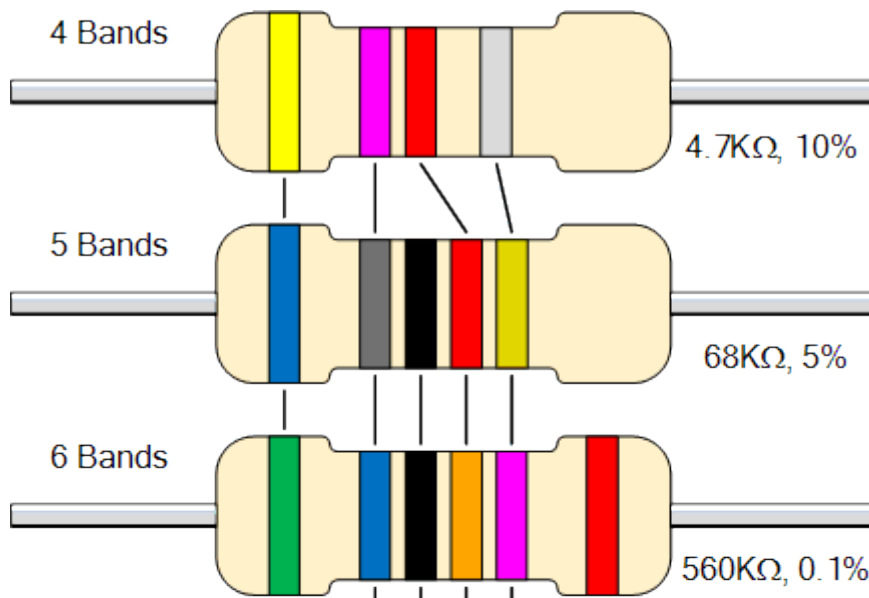

	1st Digit	2nd Digit	3rd Digit	Multiplier	Tolerance	Temperature Coefficient
0	0	0	0	0.01	10%	100ppm
1	1	1	1	0.1	5%	50ppm
2	2	2	2	1	1%	25ppm
3	3	3	3	10	2%	
4	4	4	4	100	0.5%	
5	5	5	5	1k	0.25%	
6	6	6	6	10k	0.1%	
7	7	7	7	100k	0.05%	
8	8	8	8	1M		
9	9	9	9	10M		