



# 8900TL Installation Instructions

## Product Overview:

The 8900TL is a bright LED brake light and running light that mounts underneath the chopped fender of your Harley Davidson motorcycle. This center-mount running and brake light commands the attention of following vehicles.



## Typical Installation

Normal installation requires only a few tools, takes less than 15 minutes.

### Required Tools

- Philips-Head Screwdriver
- Scotch Locks, Wire Nuts or Soldering Gun



## Installation Warning

If you feel uncomfortable installing this product, we recommend having a professional complete the installation. Eagle Lights LLC is not liable for any damage to the product or vehicle due to an improper installation.

If you have questions about the installation, please feel free to call us at 1-800-921-3162 or email us at [Support@EagleLights.com](mailto:Support@EagleLights.com).

## Installation:

Below are steps for a typical installation on most '14-later XL883N, XL1200NS, XL1200V, XL1200X, XL1200XS and models equipped with Chopped Rear Fender Kit P/N 60236-XX and side-mount license plate. Will not fit models with center-mount license plates. Steps may be different depending on the model. Please ensure you have read through the instructions and understand them clearly before attempting the installation.

 <b>WARNING!</b> 
<ul style="list-style-type: none"><li>• To prevent possible electrical shock, disconnect the negative battery terminal before installing this product.</li></ul>

1. If equipped, remove the stock reflector.
2. Thoroughly clean the area inside the rear fender where the light will be mounted and along the inner left side of the fender.
  - a. Clean the mounting area of the fender thoroughly with soap and water.
  - b. Clean the mounting area of the fender with an approximately 1:1 mixture of isopropyl alcohol and water.
  - c. Allow the fender to dry completely.
3. Remove the protective covers from the 3M adhesive pads on the light.
4. Firmly press the light onto the bike underneath the fender. Hold the light into place for approximately 2 minutes. The adhesive pads are pressure sensitive. Press each portion of the light firmly for the best adhesion.
5. To wire the tail light, locate the rear lighting harness.
  - a. Disconnect the harness.

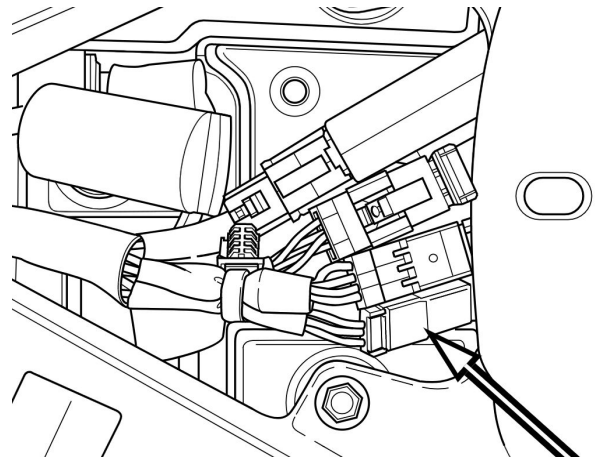

6. Route the wiring for the tail light along the inside of the fender to the fender pass through hole. Wire ties or clips (not included) can be used to secure the wiring.
7. Splice in the harness to the rear lighting harness.
  - a. Red - Brake Light Positive
  - b. Green - Running Light Positive
  - c. Black - Ground
8. Reconnect rear lighting harness.
9. Test brake light functions.