

LR-1500 UNDERSINK LEAD FILTRATION SYSTEM



APPLICATIONS

- ◆ Residential

FEATURES • BENEFITS

- ◆ Professional grade lead reduction drinking water system
- ◆ NSF/ANSI Standard 53 certified to reduce cysts such as *Cryptosporidium* and *Giardia* by mechanical means
- ◆ Full flow technology means no separate faucet required
- ◆ Complete system with wrench, integrated mounting bracket, and manual

INSTALLATION TIPS

- ◆ Choose a mounting location suitable to support the full weight of the system when operating.
- ◆ Make sure to properly lubricate o-ring prior to use.
- ◆ Use 3/8" quick connect water line.
- ◆ Install vertically with bowl hanging down.
- ◆ Allow 2-1/2" (6.35 cm) clearance below the cartridge for easy cartridge replacement.

OPERATION TIPS

- ◆ Replace cartridge if flow rate decreases.
- ◆ Do not exceed service flow rate.
- ◆ Inspect o-ring during each cartridge change. Lubricate and/or replace if necessary.

SIZING

- ◆ Service Flow Rate: Maximum 2.5 gpm

INCLUDES

- ◆ 10" standard filter housing with integrated mounting bracket cap
- ◆ 10" Filter cartridge
- ◆ Wrench
- ◆ Installation kit
- ◆ Installation and operation manual

LR-1500 UNDERSINK LEAD FILTRATION SYSTEM

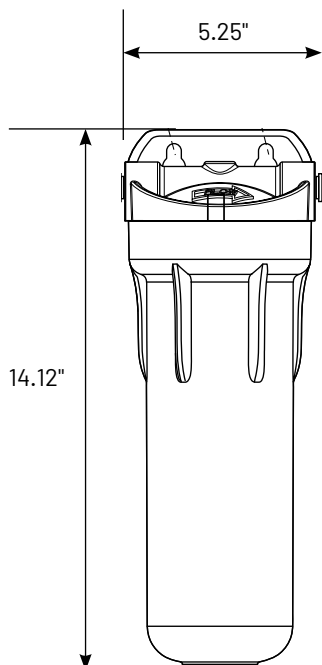

SPECIFICATIONS

- ◆ **System** (Model/Part No.)
LR-1500 / 160406
- ◆ **Housing Size**
10" Standard
- ◆ **Inlet Size**
3/8" OC
- ◆ **Housing Material**
Polypropylene
- ◆ **Length**
14.12"
- ◆ **Width**
5.25"
- ◆ **Cartridge Type**
Fibredyne[®] Carbon Block
- ◆ **Micron Rating**
0.5
- ◆ **Filter Life***
1 Year
- ◆ **Capacity**
1500 gallons
- ◆ **Flow Rate**
2.5 gpm*
- ◆ **Certification**
NSF/ANSI Std. 53
- ◆ **Pressure Range**
40-125 PSI
- ◆ **Temperature Range**
40° - 100°F
- ◆ **Replacement Cartridge**
(Model/Part No.)
LR-FB10 / 655208-43 (12/case)

* Depending on faucet limitations.



System Tested and Certified by NSF International against CSA B483.1 and NSF/ANSI Standard 53 for the reduction of Lead and Cyst.

EPA # 090375-MEX-001



13845 Bishops Dr. | Suite 200 | Brookfield, WI 53005 | United States
P: 262.238.4400 | Customer Care: 800.279.9404 | tech-support@pentair.com | pentair.com

§For a detailed list of where Pentair trademarks are registered, please visit www.pentair.com/en/registrations.html. Pentair trademarks and logos are owned by Pentair plc or its affiliates. Third party registered and unregistered trademarks and logos are the property of their respective owners.

© 2019 Pentair Residential Filtration, LLC. All rights reserved.

4005275 Rev C DE19