

# Aquasafe

systems

## Installation Instructions for:

### Home II Reverse Osmosis System



### Home II Reverse Osmosis System COMBO



### Installation Instructions Pre-amble.

This Aquasafe Reverse Osmosis System has been specifically designed as a DIY (Do It Yourself) unit for easy installation and maintenance purposes. You will insure a successful installation as well as reliable operation by carefully reading this manual and following its operational guidelines.

Your system requires a **minimum of 50psi** inlet water pressure. City and municipality water utilities are mandated to provide a minimum of 50psi however sometimes this is not what results. If you are on a well system or on city/municipal water supply and have less than 50psi we highly recommend a fully automatic booster pump which is found on our websites general parts and accessories page. We also highly recommend a booster pump if your water is extremely turbid with ppm counts beyond 600ppm.

The installation instruction that follow are extremely detailed. if a leak is experienced during installation, please see the **Leak Prevention Section** on page 15.



**ATTENTION:** It is extremely important to change the filters of your system in order to ensure ultra pure water is being produced for you and your loved ones, (which is the whole point to your system) and also to prevent premature fouling of the TFC Filmtec Reverse Osmosis Membrane of your system. After your installation is complete, please read over the **Filter Change Schedule** section (page 16) and remember to mark on your calendar when your systems filter changes need to be conducted. Filter changes on Aquasafe's Reverse Osmosis Systems are both inexpensive and very easy to do.

# Contents

## Installation Instructions for Home II Reverse Osmosis System & COMBO

Installation Instructions Pre-amble.....	i
1.0 Relax, take your time. You will find this process easy and straight forward.....	1
2.0 Take everything out of the box .....	2
3.0 Remove the protective plastic from the prefilters.....	2
4.0 Inserting the R.O. Membrane .....	3
4.1 Inserting the pre-filter elbow adaptors.....	3
5.0 Preparing the Feed Water to your system .....	3
5.1 Special note about braided wire plumbing.....	4
5.2 Installing the Needle Piercing Saddle Clamp to the cold water line.....	4
5.3 Connecting the feed water line to your system.....	4
5.4 Piercing the cold water line.....	5
5.5 Flushing of the Pre-filters.....	5
6.0 R.O. Membrane feed water line hook-up (pre-filter to R.O. Membrane) .....	6
7.0 Setting the Flow Restriction Ratios of your System.....	7
8.0 Installing the Final Polishing Filter .....	9
9.0 Prepare the R.O. Water Holding Tank .....	10
10.0 Clear the Decks.....	10
11.0 Preparing the Discharge Water Saddle Clamp.....	11
12.0 Installing the Faucet.....	12
Extra information for the Home II COMBO.....	13
Where do I install the PSI Meter from my "COMBO" System?.....	13
How do I use the TDS Meter from my "COMBO" System? .....	14
How do I store my extra case of 21 (6 changes) pre filters? .....	14
<b>Leak Prevention Page .....</b>	<b>15</b>
Threaded Fittings .....	15
Pre-Filter Canister Housing .....	15
<b>Home II System Filter Change Schedule .....</b>	<b>16</b>
Stage 1,2 & 3 Pre-Filters – When to conduct a filter change.....	16
Stage 4 – When should I change the reverse Osmosis Membrane? .....	16
Testing to see if your R.O. Membrane needs replacing.....	17
Are you unsure when you replaced the R.O Membrane Last? .....	17
Stage 5 – When should I change the Final Polishing Filter? .....	18
<b>Home II System Filter Change Instructions .....</b>	<b>18</b>
Pre-Filters – How to conduct a filter change.....	18
R.O. Membrane – How to change the R.O. Membrane of your system.....	19
Final Polishing Filter - How to change the Final Polishing Filter.....	21
<b>Water Systems &amp; Parts Warranty Information .....</b>	<b>22</b>

# 1.0 Relax, take your time. You will find this process easy and straight forward.

Simply follow the step by step instructions below. Please do not make the mistake of skipping a step.

**FOR REFERENCE PURPOSE ONLY:** Directly below is a schematic showing the positioning of all tubing in a fully set up system. Please read the instructions step by step. The install is straight forward but reading through each step is crucial to completing your install properly in the least amount of time possible.

The installation should take between 60 to 90 minutes and when all is set up you will have ultra pure, healthy drinking water for the health and enjoyment of you and your loved ones.

**Did you know?** Reverse Osmosis literally is the most powerful water filtration method known to man.

★ **Congratulations,** you have just taken a huge step towards better overall health and well being.

## Home II - Front View

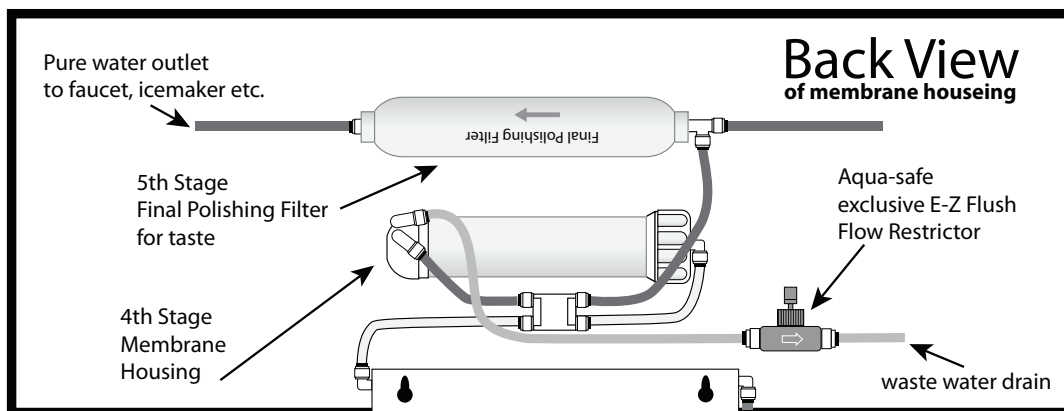
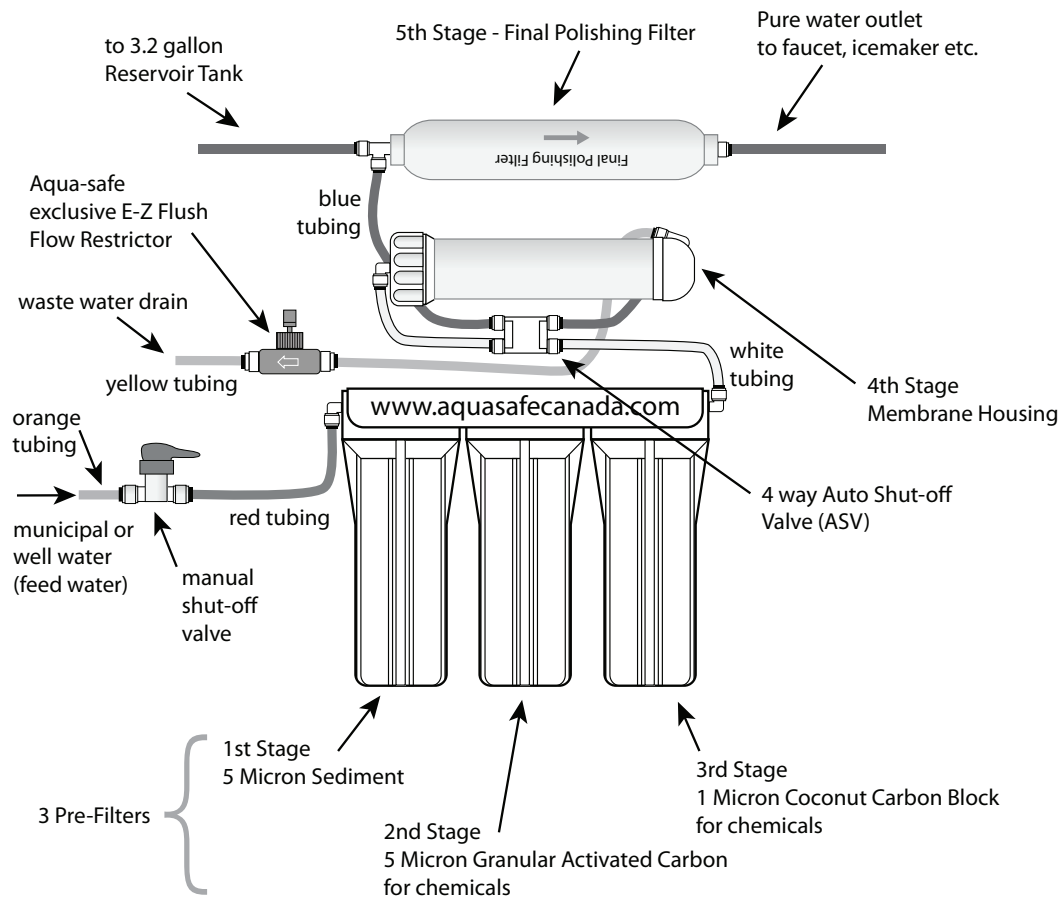

## 2.0 Take everything out of the box

Examine the contents of the Large and Small parts bag against the photos below. If any pieces are missing, check the box, sometimes the pieces can fall out of their bags during the system's journey to you.

**Figure 1**

Small Parts Bag

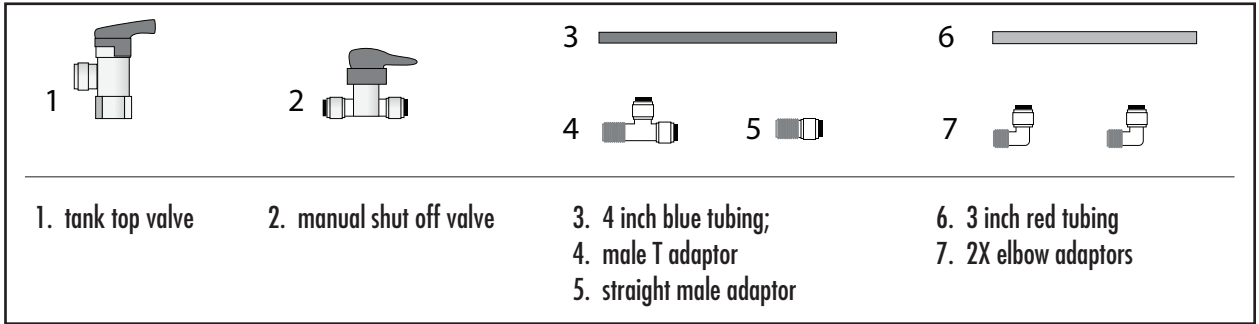

**Figure 2**

Large Parts Bag

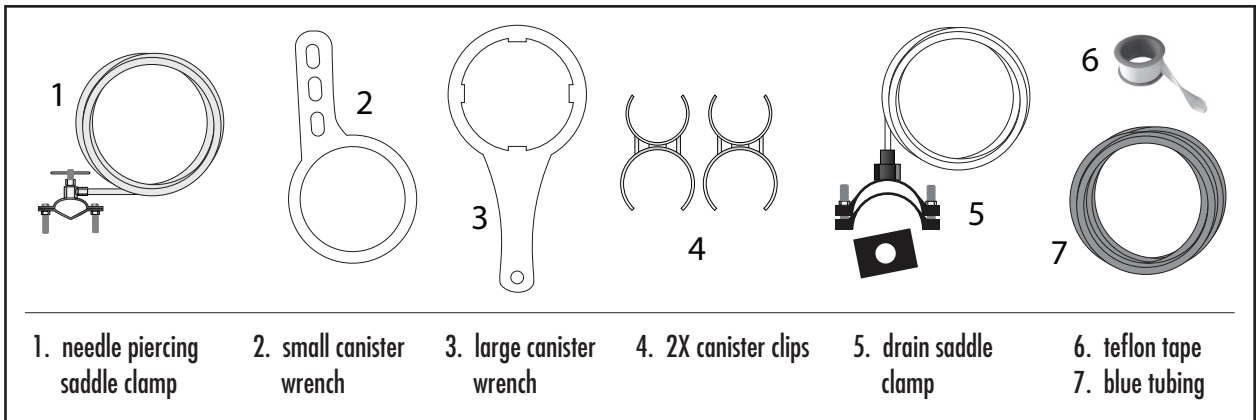

## 3.0 Remove the protective plastic from the prefilters

Inside each of the three prefilter canisters you will find a prefilter with protective plastic for quality assurance purposes. Paying close attention to how the filter is sitting inside the prefilter housing, remove the plastic and then reinsert the prefilter the same way the prefilter was taken out. Do this one at a time. If by chance you loose track of which filter goes into which prefilter canister, the SED (sedimentary filter) is stage one, the GAC (granular activated carbon filter) is stage two and the CCB (coconut carbon block filter) is stage three. See pictures below of the three prefilters. The GAC is the only one of the three prefilters that only goes in one way. The GAC must be placed with the gasket up and the plastic mesh down.

**Figure 3**

The three pre-filters



With the prefilters inside each prefilter canister, carefully screw the canisters into place. Try to keep the prefilters centered as much as possible during this process. Now, using the large canister wrench from the Large Parts Bag, tighten each of the prefilters with reasonable force in order to seal the filters into place.

## 4.0 Inserting the R.O. Membrane

**Figure 4**  
Inserting the R.O. Membrane in to its housing

The R.O. Membrane is shipped sealed for freshness. Remove the R.O. Membrane from its sealed plastic bag and insert the membrane firmly into the R.O. Housing (see Fig 4). It can only go in one way, the end with the two small o-rings is to be inserted first.

**Please Note:** It is extremely important the two small black "O" rings on the tip of the membrane seal tightly into place inside the membrane housing. Please make sure to insert the membrane as firmly as possible into the membrane housing.

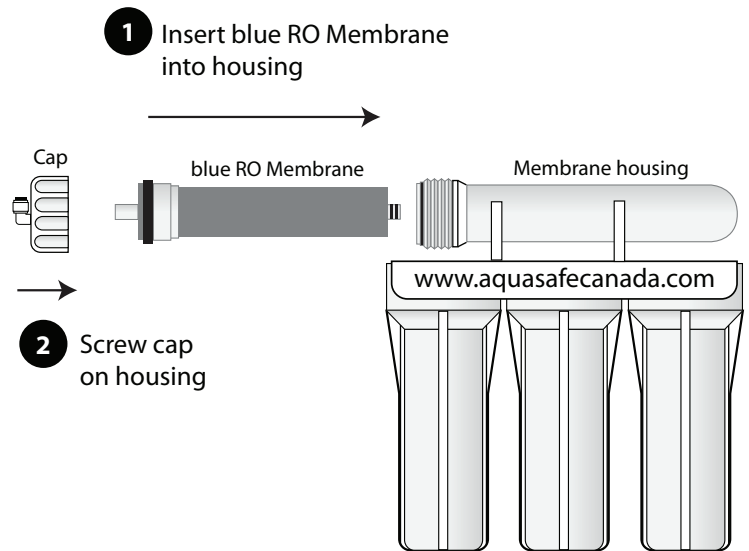

If need be you can use a pair of needle nose pliers or similar tool to grip the white cylinder protruding from the base of the RO Membrane to gain the leverage needed to push the membrane entirely into its proper position.

When you are certain the Reverse Osmosis Membrane is firmly in place screw the R.O. Membrane housing cap back into its place (Fig 4) and then tighten with reasonable force using the small canister wrench from the Large Parts Bag.

## 4.1 Inserting the pre-filter elbow adaptors

**Figure 5**  
Screw elbow adaptors into both sides of the pre-filter housing

Using two of the elbow adaptors from the Small Parts Bag, screw one of them into the "INLET" (left) side of the three pre-filters (Fig. 5) and the other into the "OUTPUT" (right) side of the three pre-filters (Fig 5).

🔥 **Please note:** Apply 4-7 wraps of Teflon tape, found in the Large Parts Bag, on each of the elbow adaptors *throughout this installation* to prevent any possible leaks.

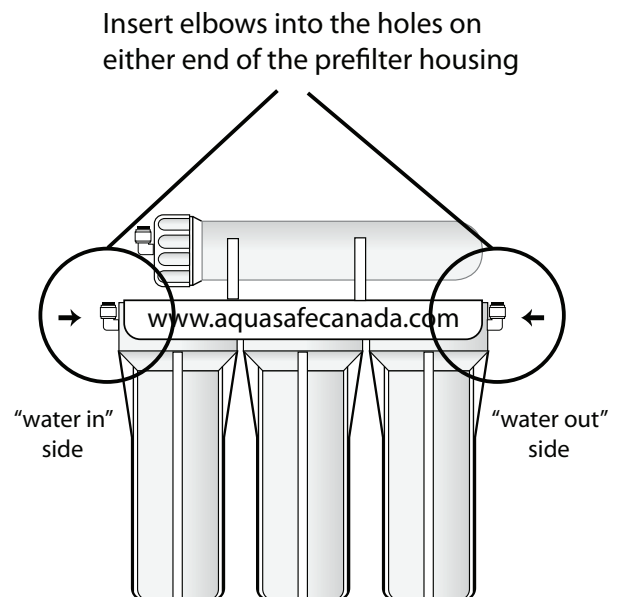

## 5.0 Preparing the Feed Water to your system

Found under your sink are the water supply shut off valves to your hot and cold water lines. You will need to SHUT OFF the cold water valve. Run the hot water for 30 seconds and then feel which line under your sink is warm. SHUT OFF the opposite water line – since that will be the cold water line. After this valve is off, turn ON your sink's cold water tap to make sure there is NO cold water flowing from your kitchen sink faucet. If you shut the valve off correctly, there should be no cold water flowing.

## 5.1 Special note about braided wire plumbing

**Figure 6**

Braided undersink plumbing. DO NOT attempt to install onto this kind of plumbing.

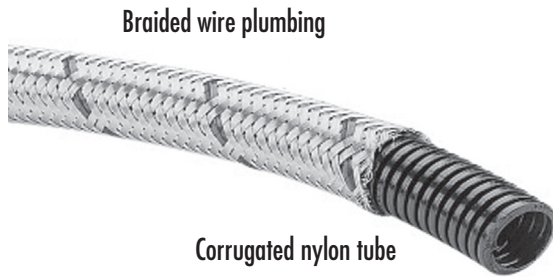

**Please Note:** DO NOT ATTEMPT TO INSTALL THE NEEDLE PIERCING SADDLE CLAMP TO BRAIDED WIRE PLUMBING (Fig. 6).

You can install the needle piercing saddle clamp to all other forms of cold water lines found under the common sink, just not the kind of plumbing depicted in Fig 6. The braided plumbing in Fig 6 is too soft a material and will therefore not allow for the

proper seal needed. The inside of braided plumbing lines may vary and therefore may look differently from this example. Don't let this confuse you. If the plumbing line is braided, DO NOT attempt to install the feed water needed piercing valve to it. If you have this kind of plumbing there is usually a piece of copper pipe that is located directly under your kitchen sink's faucet assembly which you can mount to OR see our 3/8" x 3/8" x 1/4" plumbing adaptor on our website.

## 5.2 Installing the Needle Piercing Saddle Clamp to the cold water line.

Rotate the horizontal turning bar of the needle piercing valve to the left (counter clockwise) as you do not want to pierce your cold water line at this stage. Make sure the needle is retracted all the way. Next, clamp your cold water line TIGHTLY using the needle piercing saddle clamp which can be found in your Large Parts Bag. (Fig. 7) You will need a Phillips screwdriver and small pair of pliers for this step.

**Figure 7**

Needle piercing valve in place on home's cold water line.

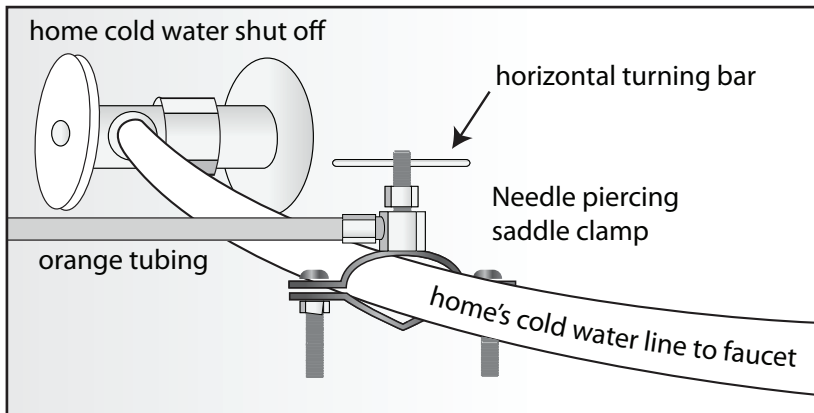

**Be sure to install above your sink's shut off valve.**

**DO NOT ATTACH TO THE HOT WATER PIPE—AS HOT WATER WILL DAMAGE THE FILTERS WITHIN YOUR SYSTEM.**

**DO NOT PIERCE THE COLD WATER LINE AT THIS STAGE!**

## 5.3 Connecting the feed water line to your system.

Next, take the 2-4 Inch piece of red tube from the Small Parts Bag and insert it into the elbow on the "INLET" (left) side of the pre-filters (Fig. 8 - next page), then take the manual shut off valve, also found in the Small Parts Bag, and attach it to the other end of the red tube (Fig. 8 - next page).

**TIP**

To more easily insert the tubing into the various fittings of your system it is helpful to remove the blue "C" clip from around the collet and then insert the tubing. After the tubing has been inserted into place, pull lightly on the tubing in order to make room for the collet and then place the collet back into its original position. The blue "C" clip holds the collet in its proper position while the system is in operation.

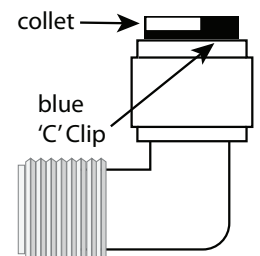

◆ Please make sure to **FIRMLY** push the tubing into the various fittings throughout this installation.

Now insert the needle piecing saddle clamp's orange tubing into the other side of the Manual Shut Off valve completing the feed water line pathway to your filtration system.

### Figure 8

Complete the feed water pathway to your system by following the diagram

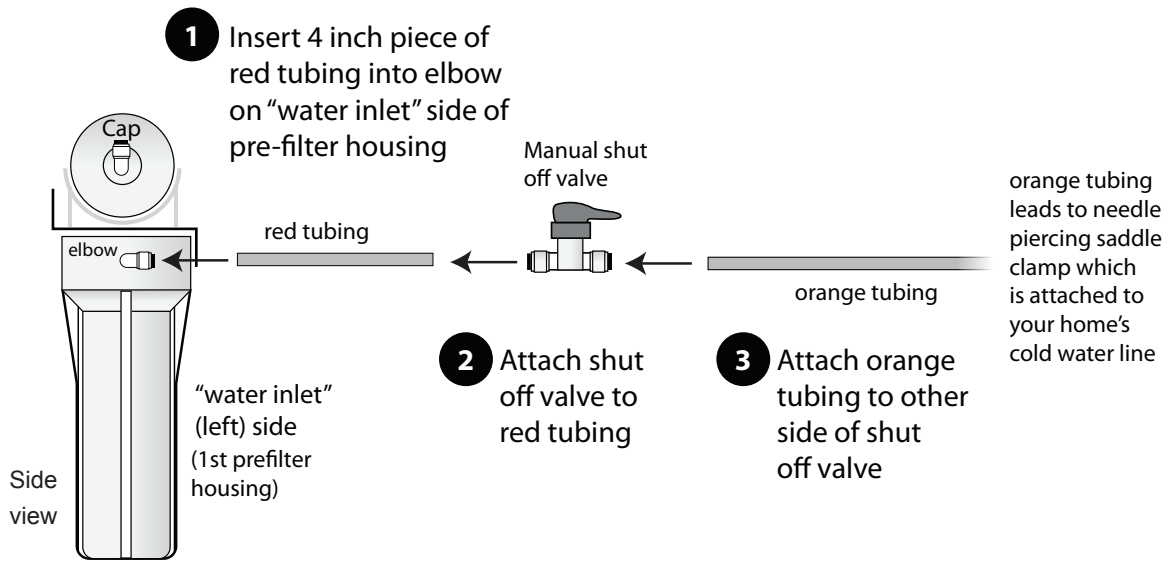

## 5.4 Piercing the cold water line

Ensuring the needle piecing saddle clamp is firmly in place, screw down the needle of the saddle clamp using the horizontal bar on top of the clamp.

**Note:** You will feel resistance when the needle is piercing the cold water line, so pay attention to the amount of resistance experienced. This resistance will stop when you have successfully pierced the cold water line. **CAUTION:** Do not screw in the needle valve to its maximum depth as you then risk piercing the opposite side of your cold water line.

After the cold water line has been pierced, turn the horizontal bar on the top of the clamp counter clockwise (left) until it becomes snug. This retracts the piercing needle creating a path for feed water to flow into the orange tubing – supplying your system with its feed water.

**PLEASE NOTE:** Do not turn your home's emergency cold water shut off back to its ON position yet!

## 5.5 Flushing of the Pre-filters

### Figure 9

Flushing the pre-filters

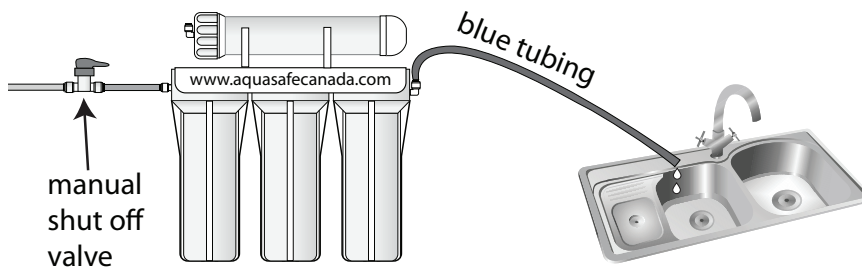

Found in your Large Parts Bag is a coiled length of blue tubing. Uncoil the tubing and insert one end into the "OUTPUT" elbow (right side) of the three pre-filters and place the other end of the blue tubing into your kitchen sink. (Fig 9)

This will allow for the water to flow through the three pre-filters and then into your kitchen sink, flushing out any and all loose particulates and carbon dust thereby preventing these initial loose particulates from reaching the 4th stage (Reverse Osmosis Membrane) ensuring maximum life span of the Reverse Osmosis Membrane.

You can now turn your home's emergency cold water shut off valve back to its "ON" position. **Please note:** By turning the cold water shut off valve back to its "ON" position you are allowing for the flow of cold water to the system. The system's three pre-filters will then fill with water which will come out of the blue tube that is placed in your kitchen sink.

Allow the water to run through your system for 20 minutes to ensure proper flushing of the three pre-filters. After the 20 minute pre-filter flush, turn the manual shut off valve, found on the feed water line (see Fig 9), 90 degrees to the tubing as this will stop the flow of water to your system.

Next, following the diagram below, remove the blue tubing inserted into the "OUTPUT" (Right Side) of the prefilters that you just used to flush the three prefilters.

**Figure 10**  
How to disconnect tubing using the 'quick-release' collet

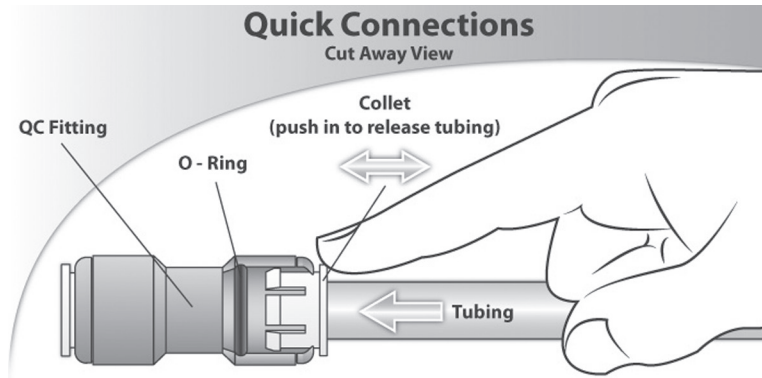

To remove tubing from any point on your system simply follow this diagram (Fig. 10) You can easily remove the tubing from any fitting on your system by removing the blue "C" clip which will expose the "collet". Then simply push in the collet so that it is flush with the fitting and then pull out the tubing.

**Please note:** In the future, be sure to de-pressurize your system before removing tubing from any fitting on your system. To de-pressurize your system you simply need to turn the manual shut off valve, found on the feed water line, to its 90 degree (OFF) position, then turn your tank top valve, found on top of the water holding tank, to the 90 degree (OFF) position and then press down on your faucet. De-pressurizing your system is extremely easy and takes just seconds.

**NOTE:** At *this* stage of the installation you have not yet installed the water holding tank or the faucet and therefore, by simply turning the manual shut off valve to its 90 degree position, you have successfully depressurized the system and you can now remove the blue tubing used to flush the pre-filters from the "OUTPUT" (right side) of the pre-filters.

## 6.0 R.O. Membrane feed water line hook-up (pre-filter to R.O. Membrane)

**Figure 11**  
Connect the short white water lines attached to the auto shut-off valve

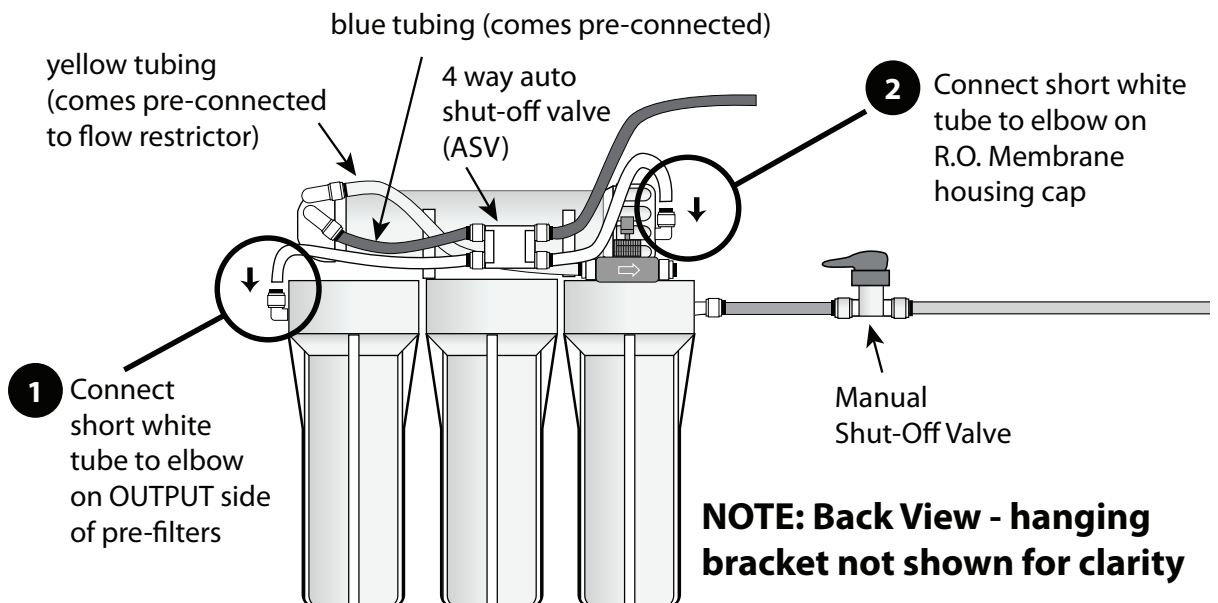

**NOTE: Back View - hanging bracket not shown for clarity**



Take the short white tube connected to the "IN" side of the 4 way auto shut-off valve (ASV) on the top of the unit and insert it into the elbow adaptor on the "OUTPUT" (right side) of the pre-filters. (Fig. 11) Remember to insert the tubing firmly. Next, take the short white line connected to the "OUT" side of the 4 way auto shut-off valve (ASV) on the top of the unit and insert it into the elbow adaptor on the cap of the R.O. Membrane housing (Fig 11).

These two white tubes complete the connection between the pre-filters and the R.O. Membrane.

## 7.0 Setting the Flow Restriction Ratios of your System.

Using the same blue tubing used to flush the pre-filters, insert one end of the blue tubing into the E-Z Flush Flow Restrictor (Fig 12). After you have inserted the blue tubing into the E-Z Flush Flow Restrictor, insert the other end of the blue tubing into your kitchen sink. The water that will flow through your E-Z Flush Flow Restrictor is referred to as "BRINE" water and will discharge into your drain washing away the harmful particulates removed by the R.O Membrane.

**Figure 12**  
Preparing to set up the E-Z Flush Flow Restrictor

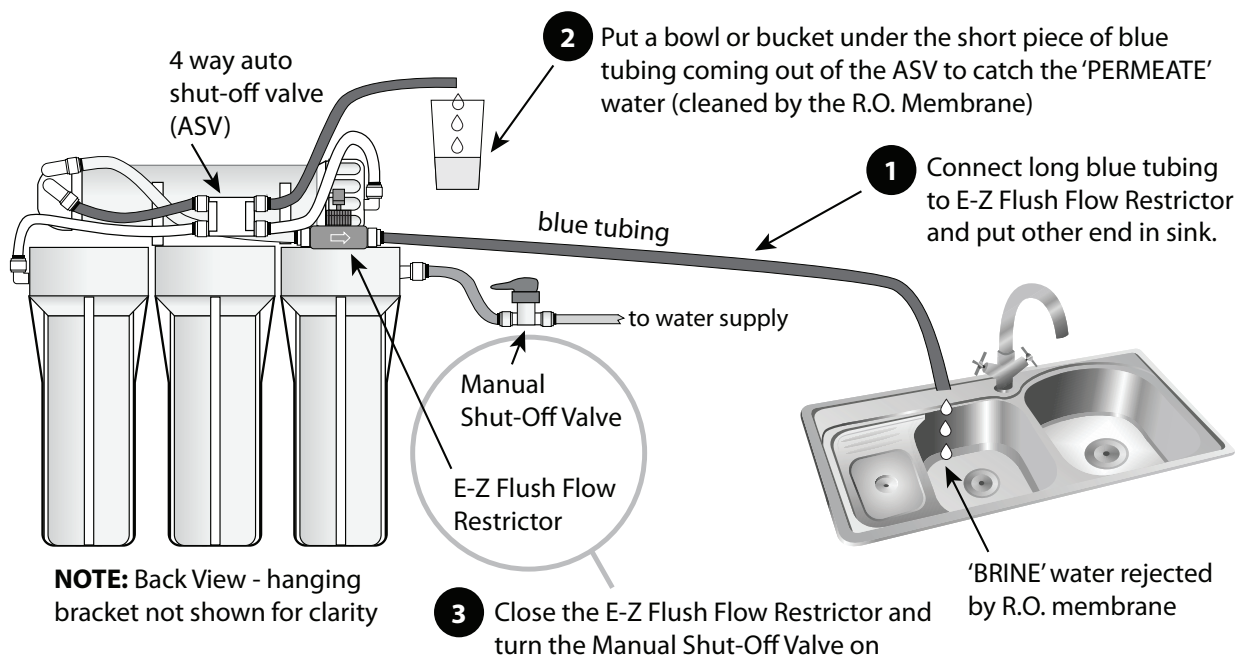

Next, get a bowl or a bucket and place it under the short piece of blue tubing that is coming out of the auto shut-off valve (ASV). The water that will flow out of the short piece of blue tubing that is coming out of the auto shut-off valve (ASV) is the purified water produced by the R.O. Membrane and is referred to as "PERMEATE" water.

Now, turn the dial on top of the E-Z Flush Flow Restrictor clockwise (Right), entirely closing the valve of the E-Z Flush Flow Restrictor and then turn the Manual Shut-Off Valve (Fig.12) found on the feed water supply line of your system to its "ON" Position. Within a moment PERMEATE water will begin to flow out of the short blue piece of tubing coming out of the Auto Shut Off Valve (ASV), at the rate of a very fast drip to a slow trickle. Air inside the R.O. Membrane will be forced out causing the fast drip or slow trickle to sputter with the air escaping. Wait 2-3 minutes for the air to fully purge so that a steady output is achieved from the R.O. Membrane.

Next, carefully open the dial on-top of the E-Z flush Flow restrictor counter clockwise (left) VERY SLOWLY until the amount of BRINE water flowing through the E-Z Flush Flow Restrictor is flowing THREE TIMES FASTER than that of the PERMEATE water flow coming out of the RO Membrane. In this way

you achieve a 3:1 ratio where 3 parts is BRINE water and 1 part is PERMEATE water. (You can do this by judging the flow visually or see the note below for how to do a timed measurement.)

When you are confident that you have properly set the flow ratios as explained above, locate the "marker sleeve" which is found directly under the top dial of E-Z Flush Flow Restrictor. Screw this marker sleeve down the threads of the shaft of the dial so that it is flush with the main body of the E-Z Flush Flow Restrictor. This will serve as an exacting marker to the amount of flow restriction you have set. Now turn the Manual Shut-Off Valve back to its (OFF) position and remove the blue tubing from the E-Z Flush Flow Restrictor.

**Figure 13**  
Timing flow rates  
to set up the  
E-Z Flush Flow  
Restrictor

**PLEASE NOTE:** The 3:1 ratio depicted above can easily be achieved by visually judging the rate of the BRINE / PERMEATE flows. However if you want to achieve exacting ratios between brine and permeate water you can simply time how long it takes to fill a certain volume such as a measuring cup or the like (Fig 13). When doing this "timed measurement" the permeate water should take three times as long to fill the same volume over that of the brine water (3:1 Ratio). We do not recommend anything over a 1:1 ratio as it is extremely important for the R.O. Membrane to have adequate BRINE flow to be able to flush away the harmful particulates it is removing while filtering the water. A setting near to or at 1:1 ratio is only recommended if you are in a desert environment and need to conserve as much water as possible or if you are charged large sums of money per gallon from your water utility. A RATIO BEYOND 1:1 IS VERY LIKELY TO DAMAGE THE R.O. MEMBRANE. YOU SHOULD ALWAYS HAVE MORE BRINE WATER FLOW THEN PERMEATE WATER FLOW.

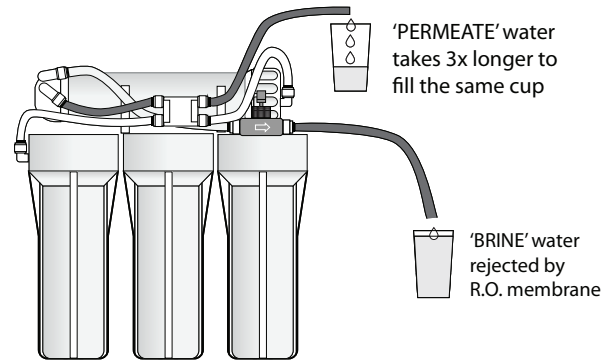

For your convenience this system is fully automatic! When you draw water from the Aquasafe faucet, the system will auto-fill its holding tank and then shut off until more water is drawn from the system where the cycle would then repeat. This means that you will always have an abundance of pure, healthy water on tap at any given time you desire.



The permeate water coming directly out of the R.O. Membrane housing (via the auto shut-off valve) should achieve an 85% or greater reduction in ppm (parts per million) from that of your unfiltered cold tap water in your home that has not been filtered by this system. If a TDS Meter was ordered with your system gather a few ounces of water in a small glass and test the ppm's - comparing the ppm count of the permeate water coming directly out of your R.O. Membrane against that of your home's unfiltered cold water. It may take up to 15-20 minutes for the RO Membrane to become fully activated and flushed of its food grade preservative to achieve this minimum 85% ppm reduction Example: Home's unfiltered tap water is 300ppm / R.O. Permeate water should be 45ppm or less. You can find this value for *your* results by multiplying them by 0.15 (the 15% of particulates that are left when 85% have been removed). If you do not see the minimum of 85% reduction in ppm's after 20 minutes of permeate water flow, it means your R.O. Membrane is not seated properly in the R.O. Membrane housing. You will need to take the R.O. Membrane out and re-insert as firmly as possible, reassemble and then re-test the ppm's as depicted above. If you do need to re-seat your R.O. Membrane it is a very quick and easy procedure. **Testing the ppm reduction rate of the permeate water coming directly out of the RO Membrane housing is the most important ppm reduction test you can perform and is a sure way to know if your system is performing as it should.**

## 8.0 Installing the Final Polishing Filter

Push the two clips (found in the Large Parts Bag) onto the R.O. Membrane housing in preparation for the Final Polishing Filter (step 1, Fig 14).

Now push the Final Polishing Filter into the canister clips (step 2, Fig. 14). The direction of the Final Polishing Filter is important. **YOU MUST HAVE THE TEXT UPSIDE DOWN.** **PLEASE NOTE:** The reason for inserting the Final Polishing Filter with the text upside down is so the Blue hose will easily reach the "T" adaptor. You will notice an arrow engraved on the polishing filter which indicates the direction of water flow. The "T" adaptor should always be inserted on the opposite side of the polishing filter to which the arrow is pointing. In this way water will flow from the water Storage Tank, through your Final Polishing Filter, then to your Aquasafe Faucet every time you take water from the system. The Final Polishing Filter remineralizes your water to ensure it has a full-bodied taste. Because of this the ppm of the water dispensed at your Aquasafe faucet will be higher than that coming out of the R.O. Membrane.

**Figure 14**  
Attaching the  
Final Polishing  
Filter

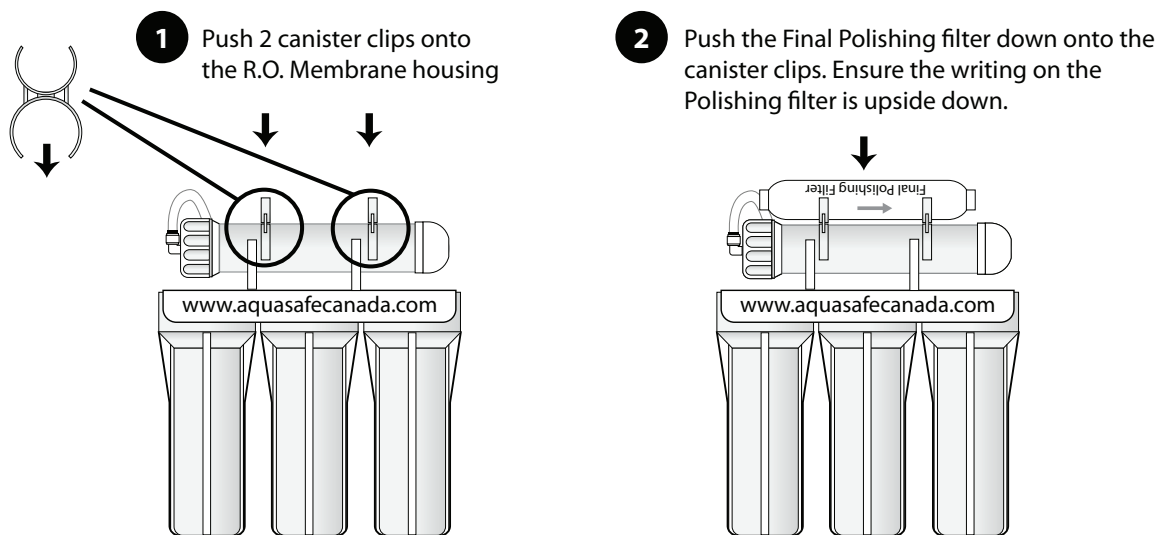

Take the male "T" adaptor from the Small Parts Bag and screw it into the left side of the Polishing Filter. Then take the straight male adaptor from the small parts bag and screw it into the right side of the Polishing Filter (steps 1 & 2 in Fig 15). **Remember to apply 4-7 wraps of Teflon tape.**

Next, Insert the short blue hose connected to the "OUT" side of the 4 way ASV (Automatic Shut Off Valve) and push it into the "T" Adaptor on the left side of the Polishing Filter (step 3, Fig 15).

**Figure 15**  
Attaching the  
Final Polishing to  
the D.I. Canister

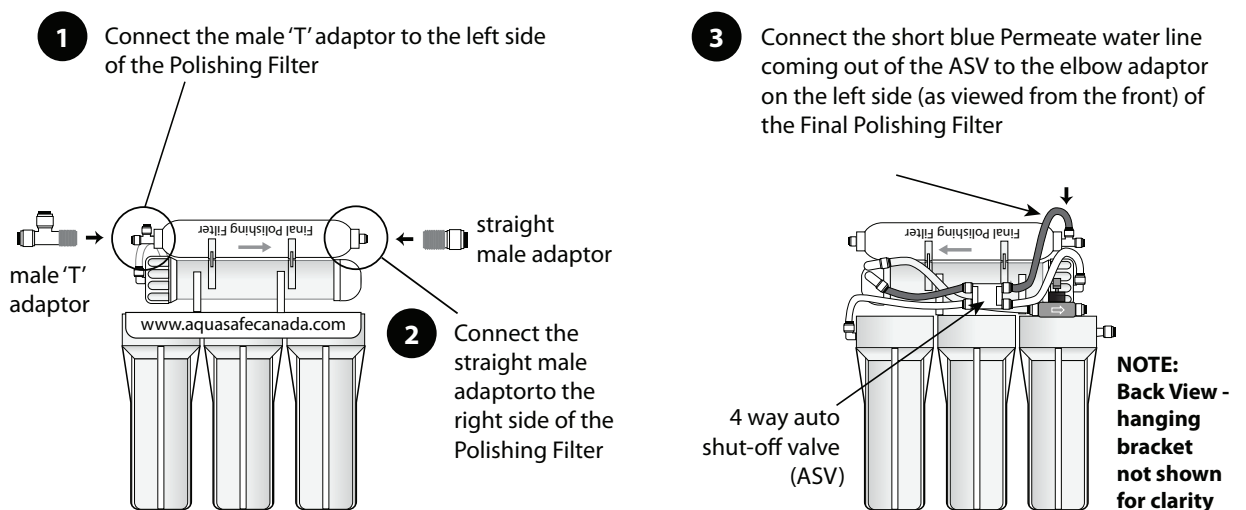

## 9.0 Prepare the R.O. Water Holding Tank

**Figure 16**

Attach the tank top valve to the R.O. Water Holding Tank

The R.O. Water Holding Tank has an air bladder and a water bladder inside it. The air bladder comes pre-set from the factory at 7 PSI for your convenience. **CAUTION:** Changes to the PSI of the air bladder inside the R.O Water Holding tank may cause harmful back pressure which can result in the Auto Shut-Off Valve (ASV) malfunctioning. As such, please do not attempt to adjust the air pressure of your R.O Water Holding tank.

**Please note:** For your convenience, the R.O Water Holding tank can stand up or lay horizontal to conserve space if necessary.

Screw the tank top valve found in your Small Parts Bag onto the threads found on top of the R.O Water Holding Tank (Fig. 16). **Remember to apply 4-7 wraps of Teflon tape to the thread of the tank itself.**

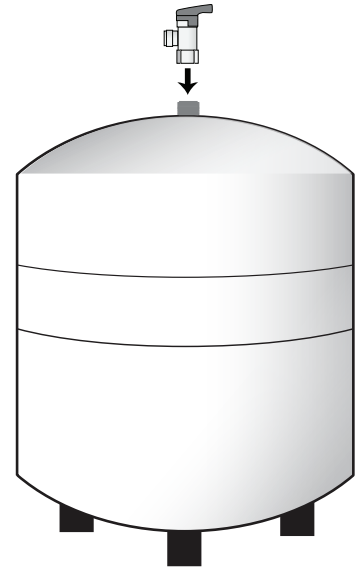

**PLEASE NOTE:** The long length of blue tubing used to flush your prefilters is the tubing you will use to hook up both the water storage tank as well as the dedicated Reverse Osmosis faucet that came with your system.

You will need to cut this length of blue tubing in two pieces accordingly. The length of tubing used to hook up your kitchen faucet (which will be attached to the left side of the Polishing Filter) will probably need to be longer than the length of blue tubing used to hook up your R.O Water Holding tank (which will be attached to the right side of the Polishing Filter). Take a moment and judge how much

tubing you will need for each purpose based upon where the final placement of your system will be located under your sink (or the like) and then cut the blue tubing to length with a sharp knife making sure your cut is straight (not at an angle).

Now insert one end of the cut length of blue tubing (for the tank) into the male "T" adaptor found on the left side of the Final Polishing Filter and the other end into the tank top valve connecting the holding tank to the system (Fig. 17).

Connect the Polishing Filter to the tank top valve using a length of blue tubing cut to fit your setup

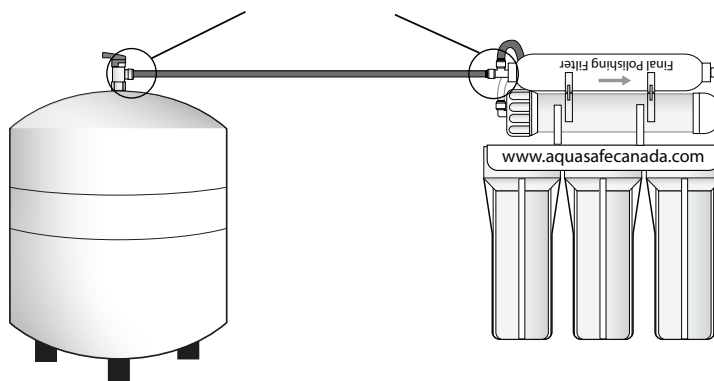

**Figure 17**

Attach the tank top valve to the Final Polishing Filter

## 10.0 Clear the Decks.

If you have not already done so, the next step is to totally clean out under your sink. Get some rags to wipe up any water drips that may be present from the installation process. Now, step back and look at where you want the unit and the tank positioned. Please remember, you have to service the system so consider accessibility.

**TIP**

Stand the unit inside a drip pan. Disposable aluminum baking sheets work fine. We suggest this because you may have water drips while servicing the system or when you change out filters.

## 11.0 Preparing the Discharge Water Saddle Clamp.

**Figure 18**

Where to install the drain saddle clamp

Find a location on the drain pipe under your sink where you wish to secure the discharge water saddle clamp found in your Large Parts Bag (Fig. 18). Make sure—**MAKE REALLY SURE**— that the location you have chosen is above the trap! (The trap is the “U” shaped part of the drain pipe) You may secure the saddle clamp on a horizontal pipe **JUST AS LONG AS YOU ARE ABOVE THE TRAP!!!** Also try to secure the saddle clamp where it will not block anything, like where you want to put your system or the R.O. Water Holding Tank.

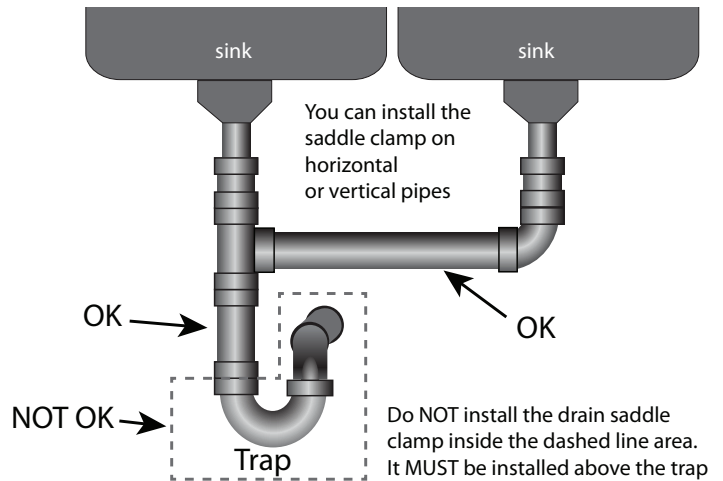

Drill out your chosen spot with a 1/4 inch drill bit. The 1/4 inch hole that you drill into the carefully chosen location on your drain pipe is where the yellow discharge line will be inserted into and secured into place with the discharge water line (Drain) Saddle Clamp.

Take the gasket that came with your Large Parts Bag and remove the backing. Then stick the gasket to the inside of the saddle clamp making sure that the yellow tubing is showing through at least 1/2 inch (Fig. 19). Now secure the saddle clamp in its chosen location firmly making sure the tubing is inserted into the drain pipe. Attach the other end of the yellow discharge line to the E- Z Flush Flow Restrictor on the back of the unit.

**TIP**

The material of the Drain Saddle Clamp is flexible. If your drain pipe is slightly larger than the circumference of the drain saddle clamp simply press the saddle clamp firmly onto the drain in order to catch the bolts on the opposite side. You only need to tighten the bolts to the point where the gasket begins to compress against your drain pipe.

**Figure 19**

Assembling and attaching the drain saddle clamp

- 1 Insert yellow drain line into quick connect fitting
- 2 Remove the backing from the gasket and stick it to the inside of the saddle clamp making sure that the yellow tubing is showing through at least 1/2 inch

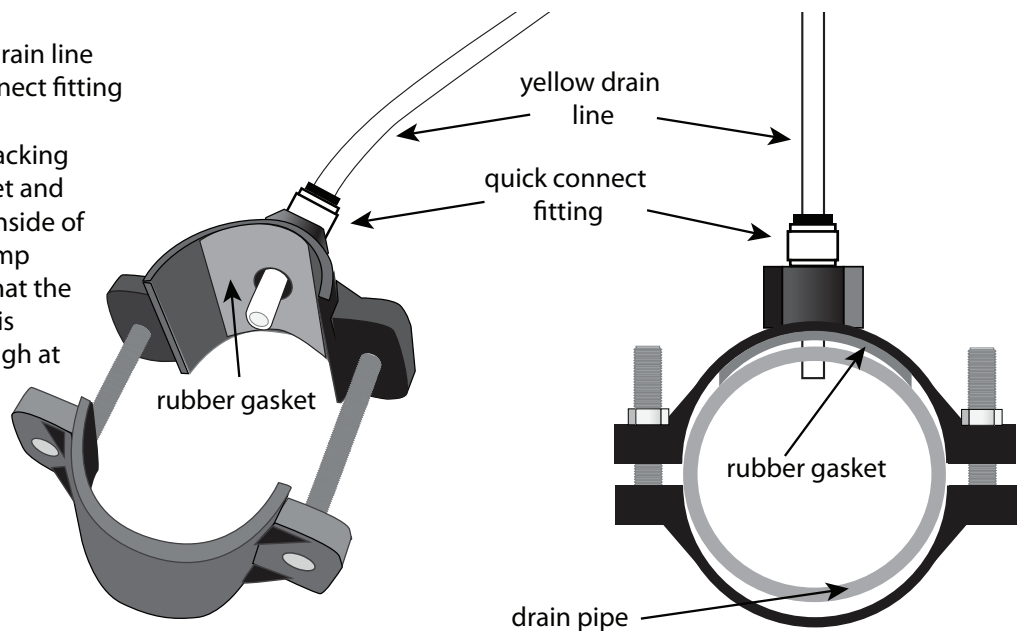

## 12.0 Installing the Faucet.

Installing the faucet is next. You will most likely be installing the faucet through the sink top or beside the sink top. Below are 4 different types of counters. Follow the instructions for your counter type. Be aware that you can drill through your stainless steel sink but you will also have to drill through whatever counter material you have underneath your sink. If you have a porcelain sink, we advise against an amateur installation. Either find another spot (like *beside* the sink) or get a Pro.

**a) Laminate:** the most common material is a laminated counter top. Choose the most appropriate spot on top, then crawl under and see where it clears. Remember, you have a large plastic washer to put under the counter. The safe thing to do is to drill a pilot hole with your smallest bit first. Then drill a ½ inch hole and assemble the faucet (refer to diagram above). The rubber gasket goes under the chrome faucet and the plastic washer goes under the counter. After putting the plastic washer in place, put on the lock washer and then tighten the nut. Either have someone hold the faucet or put a wrench on it and secure the wrench to prevent it from turning while you tighten the nut. Be careful not to damage the faucet surface.

**b) Stainless Steel:** Do the same as for laminate, except be really sure of your clearance space. Take a metal punch (or a big nail) and give the magic spot a good hit. At this indentation drill a pilot hole. A wood drill will not do it. You must use a metal drill bit suitable for stainless. Once the pilot hole is made, follow up with a ½" hole and attach the faucet.

**c) Marble or Granite:** This is not that hard, but takes some time. You need a diamond tipped drill and about 15-20 minutes. The price of a ½" diamond tipped drill is around \$75.00. Since you will probably never use it again, you would probably be better off either renting the equipment or calling in a Pro. Most glass installers have diamond drills and all vendors of stone have them. Some will rent it out, as will "Rent-All" stores. Start the hole by drilling a ½" hole in a piece of scrap wood. This will serve as a guide. Hold the piece of wood and let the diamond drill bit do the work. DO NOT push down or apply pressure. Keep the hole filled with water and wipe out the hole often. It is important to let the weight of the drill be the pressure and to let it just grind away at its own pace (which is slow).

**d) Wood:** If you have a wood counter top you could of course drill out the hole just beside the sink. Also please keep in mind that you could run the 1/4 " tubing to a location nearby your system.

**See Faucet diagram on the next page for further reference.** Follow the schematic in Fig. 20. Use the other length of blue tubing that was cut in two pieces during step 10.0 as seen above for your faucet installation. When you have your Aquasafe faucet firmly in place in the chosen location, insert the hose leading from the faucet into the straight male adaptor on the left side of the Polishing Filter.

Check over all of the steps. Make sure all of your tubing is inserted firmly into the various adaptors. You may now turn the manual shut-off valve found on your feed water line back to its "ON" position.

Your 3.2 Gallon water storage tank will now begin filling and will take a maximum 2-3 hrs to fill to capacity for its first time and quicker thereafter. Once the tank has filled, empty all the water out of the water holding tank and let refill. To empty all water from your storage tank once filled you simply need to open your faucet until the output from the faucet turns to a fast drip or slow trickle. The RO Membrane is filled with food grade preservative for quality assurance and the final polishing filter and the holding tank's water bladder should be flushed out before consuming the water. Empty two full tanks of water in order to ensure proper flushing of your entire system. After flushing two full tanks, you can then drink and cook with the ultra purified water.

After emptying your water storage tank twice, allow your system to pressurize. Monitor closely for potential leaks. If leaks do occur, turn the Manual Shut Off Valve attached to the 4 inch piece of red

**Figure 20**

Attaching the faucet

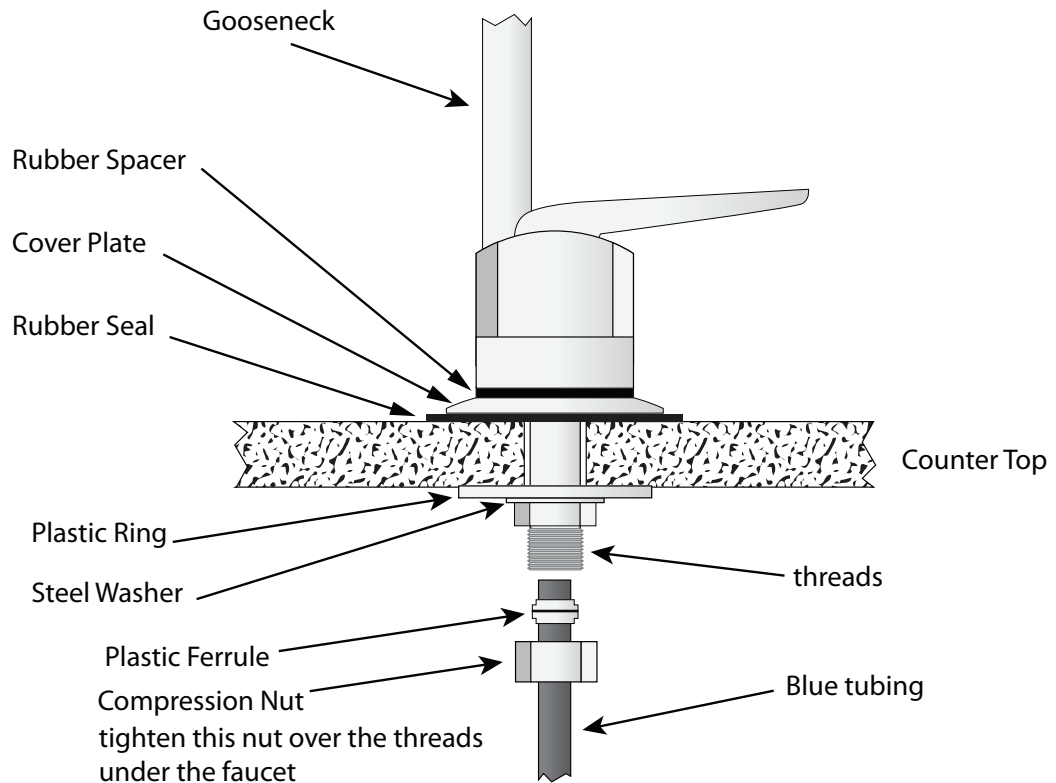

tubing found on the feed water line to its "OFF" position. The nature of water is to find the path of least resistance. Some initial small leaks are not unheard of. If a leak does occur at any time please see Aquasafe's LEAKS PREVENTION SECTION on the page 15 of this document.

GET A GOOD FLASHLIGHT AND CHECK OVER THE ENTIRE SYSTEM CAREFULLY WHEN COMPLETED TO SPOT ANY POTENTIAL LEAKS.

★ Congratulations on completing the installation process. You may now start drinking the ultra purified drinking water you desire for the health and enjoyment of you and your loved ones.

If you require further clarification after going through all of the information of these instructions, please feel free to email Aquasafe for further support at: [techsupport@aquasafecanada.com](mailto:techsupport@aquasafecanada.com)

## Extra information for the Home II COMBO

**Figure 21**

The PSI Meter

### Where do I install the PSI Meter from my "COMBO" System?

If you have purchased the Home II System Combo, your system came with a PSI Meter as seen in Figure 21. It is not necessary that the PSI Meter be installed onto your system. The PSI Meter is provided as a convenience to you as your entire system operates from water pressure. If need be, the PSI Meter allows you to determine the water pressure at any point on your Reverse Osmosis System which can make troubleshooting of any potential problems on your system extremely easy. However, if you chose to install the PSI Meter onto your system, there are two main areas where installing



the PSI Meter on your system can be of use.

1. If you are on a well water system, and you think you may have lower than 50 psi throughout your home's plumbing, a good place to install the PSI Meter is on the feed water line to your Reverse Osmosis System. This will allow for easy monitoring of the source water pressure entering your Reverse Osmosis System. Your system needs consistent pressure at 50 psi or above. Typical well water systems will top out at 60 psi and bottom out at 40 psi. If this is the case we highly recommend an automatic booster pump available on our website in General Reverse Osmosis Parts & Accessories.
2. Installing the PSI Meter on the **blue water production line (Step 2 of Fig 15)** will allow you to monitor the water pressure of the purified water that has passed through the Reverse Osmosis Membrane. This can be useful, as when the R.O. Membrane becomes clogged over time due to the contaminants it is removing, the water pressure output from the blue water production line will decrease accordingly. Installing the PSI Gauge at this location will allow you to monitor this decrease in output water pressure to let you know when you may need to replace your Reverse Osmosis Membrane.

## How do I use the TDS Meter from my "COMBO" System?



**Figure 22**

The TDS Meter

The TDS (Total Dissolved Solids) Meter of your system is extremely easy and intuitive to use and comes with its own set of instructions, but here is a quick tutorial. First you will need to get a small glass and rinse it of all dust or other particles. Now fill the rinsed glass with the water for which you would like to determine the TDS Reading (Total Dissolved Solids). Remove the cap from the bottom of the TDS Meter and turn on the meter. Now simply insert the portion of the TDS Meter that was covered by the cap into the glass of water. The number that shows on the digital display is the ppm count (Parts Per Million) of TDS (Total Dissolved Solids) in your water.

**Note:** Your TDS Meter has an auto shut off feature but try to remember to shut off the TDS Meter when you are done testing your water to save on batteries !

## How do I store my extra case of 21 (6 changes) pre filters?

Your case of 21 pre-filters (6 full changes) can be stored in the same state in which they arrived. Each prefilter comes wrapped in protective plastic. Store at room temperature. Shelf life is years.



# LEAK PREVENTION PAGE

## Threaded Fittings

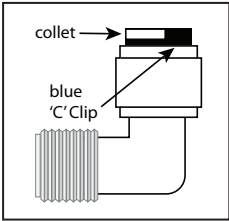

Threaded Fitting

To prevent a leak on any threaded fitting that screws into the Reverse Osmosis System you simply need to employ Teflon tape. The main instructions pages indicates the preventative measure of wrapping the threads of the various threaded fittings 4-7 times with Teflon tape.

This preventative measure will ensure against any potential leaks from the various threaded fittings throughout your Reverse Osmosis System. **ADDING SUFFICIENT TEFLON TAPE IS KEY!**



Teflon Tape

If you are experiencing a leak from a 1/4 inch tube inserted into a threaded fitting, you simply need to insert the tubing into the threaded fitting further. To do this you may need a small pair of pliers to assist you in gripping the tube. If the use of pliers is needed, grab the tubing 1/2 inch from where the tube inserts into the threaded fitting in order to not scratch the section of tube that will be inserting further into the threaded fitting. A scratched section of tubing that is inserted into a threaded fitting can act as a path for water to flow, which in turn may result in a small leak.



To more easily insert the tubing into the various fittings of your system it is helpful to remove the blue "C" clip from around the collet and then insert the tubing. After the tubing has been inserted into place, pull lightly on the tubing in order to make room for the collet and then place the collet back into its original position. The blue "C" clip holds the collet in its proper position while the system is in operation.

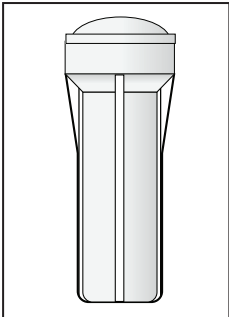

Pre-Filter Housing

## Pre-Filter Canister Housing

All Reverse Osmosis Pre-Filter Housings Are "Compression Sealed". This means that 99% of the time any leak coming from the threads of the Pre-Filter Housing can be easily fixed by tightening with the system's "large Canister Wrench".

A "Large Canister Wrench" came with the Original Purchase of your Reverse Osmosis System

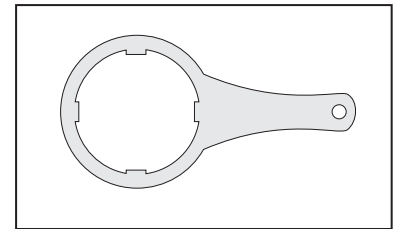

Large Canister Wrench

# HOME II SYSTEM FILTER CHANGE SCHEDULE

Pre and Post filters: Defined as the filter stages Pre (before the RO Membrane ) and Post (after the RO Membrane).

## Stage 1,2 & 3 Pre-Filters – When to conduct a filter change.

Stages 1, 2 and 3 are your system's pre-filters which need to be changed every 1000 gallons of purified water produced. The average household consumes 5 gallons of drinking and cooking water daily and as such a filter change is needed every 6 months or sooner. Mark your calendar for a routine filter change every 6 months to ensure system performance.

### TIP

If you are a 1 person household or a large family household it may be advantageous to monitor approximately how many gallons of drinking and cooking water is consumed daily to factor the proper filter change schedule for your individual situation.

- *Example:* Large household or office environment consuming 8 Gallons per day.  
 $1000 \text{ gallon pre-filter capacity} / (8 \text{ GPD} \times 30.5 \text{ average days a month}) = \text{pre-filter change approx. every 4 months.}$

**Please Note:** Maintaining the pre-filters of your system is key to ensuring system integrity in both water quality achieved and overall longevity of its parts and components. The pre-filters are your system's first line of defence - protecting and ensuring the maximum lifespan of the R.O. Membrane.

### WARNING

**IF THE PRE-FILTERS ARE NOT CHANGED BEFORE 1000 GALLONS OF PURIFIED WATER IS CONSUMED FROM THE SYSTEM, CHLORINE WILL BYPASS THE PRE-FILTERS REACHING AND CHEMICALLY DAMAGING THE R.O. MEMBRANE RENDERING IT USELESS.** Also, after the 1000 gallon mark, seepage may occur where very fine particulates will bypass the pre-filters stressing the R.O. Membrane greatly This will result in pre-mature fouling of the R.O. Membrane resulting in the R.O. Membrane needing to be replaced before its due time.

## Stage 4 – When should I change the reverse Osmosis Membrane?

The R.O. Membrane is the very heart of your Aquasafe Reverse Osmosis System. The R.O. Membrane is rated for 4000-5000 Gallons of purified water production. A new R.O. Membrane will last for approximately 3-4 years. Once again this calculation is worked out on the average as follows:

- A standard household will consume between 3-5 gallons of purified water each day for all its drinking and cooking purposes. **A 3 gallon per day consumption rate** over a year's time is equal to roughly 1095 Gallons which therefore calls for a Reverse Osmosis Membrane change approximately once every 3.5 years.
- **A 5 Gallons per day consumption rate** over a years time is equal to roughly 1825 Gallons which therefore calls for Reverse Osmosis change approximately once every 2- 2.8 Years.

If you have a TDS Meter a very simple but critical test you can perform in order to determine if your R.O. Membrane needs to be replaced is to measure the PPM reduction rate of the purified (permeate) water coming directly out of the R.O. Membrane housing (see Fig. 25 and 26 for how to do this).

## Testing to see if your R.O. Membrane needs replacing.

Step 1. How to depressurize your system (Fig 23)

**Figure 23**

How to depressurize your system

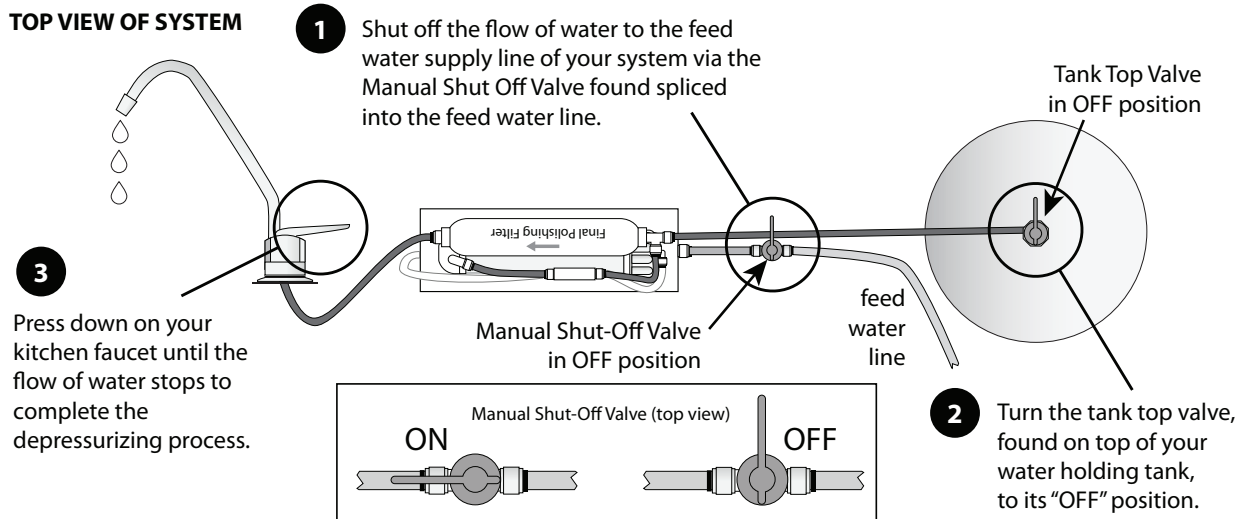

Step 2. Test your permeate water (Fig 24)

**Figure 24**

Testing your permeate water with the TDS meter

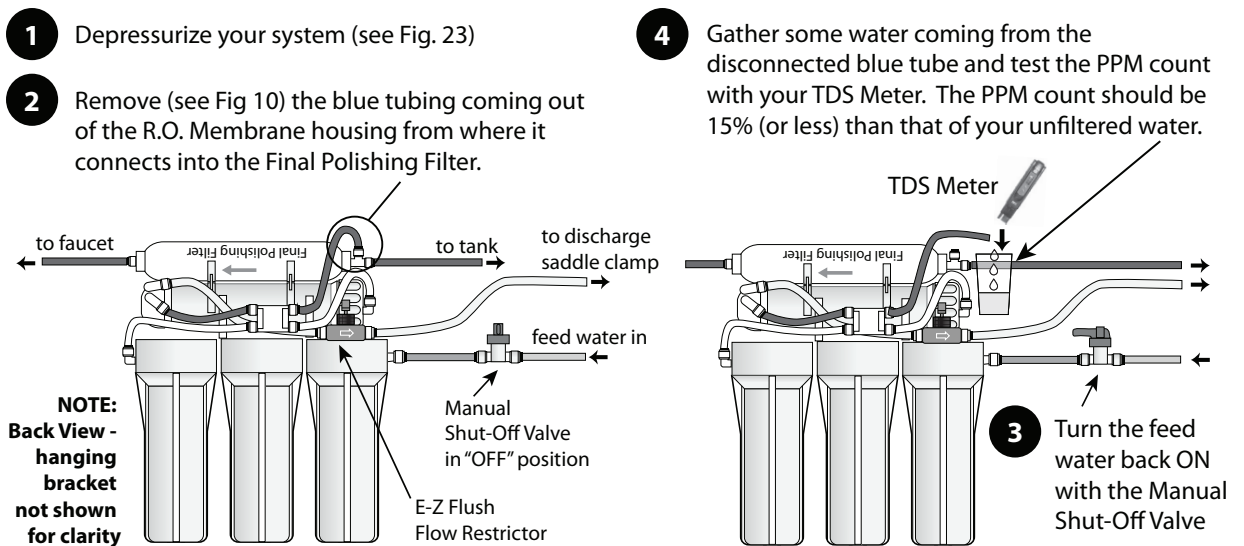

The PPM count should be 15% or less in PPM's from that of your unfiltered tap water that can be gathered from any other tap in your home.

- **Example:** if your unfiltered tap water is 200ppm then the purified permeate water coming out of the R.O. Membrane should be 30ppm or less ( $200 \times 0.15$ ).

If your R.O. Membrane is not producing the 85% or better in PPM reduction as depicted above, you need to change this membrane.

## Are you unsure when you replaced the R.O Membrane Last?

Aquasafe highly recommends you replace your Reverse Osmosis Membrane if you have never changed the R.O. Membrane of your system and your system is more than 3 years old or if you cannot remember the last time you have replaced your R.O. Membrane. If you are not sure it is better to be safe than sorry. The R.O. Membrane is the most important part of the system, therefore ensuring it is operating properly is key to properly producing the ultra purified healthy water you desire.

## Stage 5 – When should I change the Final Polishing Filter?

This is the final filtration stage in your R.O. System. The Final Polishing filter is rated for 1800-2000 gallons of purified water production and therefore should be changed every second time you change your three pre-filters.

# HOME II SYSTEM FILTER CHANGE INSTRUCTIONS

## Pre-Filters – How to conduct a filter change.

Step 1. Install the new pre-filters (Fig 25)

- 1 Depressurize your system (see Fig. 23)
- 2 Unscrew the first pre-filter housing with the large canister wrench. **Please note:** There will still be water in the housings of the filters so it will be helpful to have a cloth at hand.

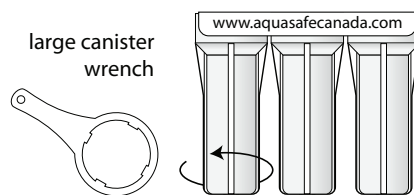

**NOTE: R.O. Membrane and other filters and hoses not shown for clarity**

- 4 Make sure the SED pre-filter is centered in the pre-filter housing. Screw the first pre-filter housing back on using the canister wrench. Use reasonable force to ensure a proper compression seal.

- 3 Remove protective plastic from the replacement SED (sedimentary) filter and insert into housing. There is no up or down to this filter.

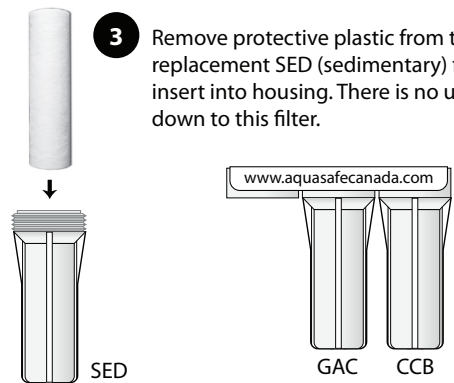

- 5 Replace the second (GAC - Granular Activated Carbon) and third (CCB - Coconut Carbon Block) pre-filters in the same way. The only filter for which direction matters is the GAC filter. **Move on to the pre-filter flush.**



Once you have finished tightening the third and final pre-filter housing to the main system, you will need to conduct a "pre-filter flush".

**Figure 25**

Changing the pre-filters

Step 2. Flushing the Pre-Filters (Fig. 26)

All water filters throughout the water filtration industry should be flushed out before final use to rinse away any initial loose particulates from the manufacturing process. This process is very easy.

**Figure 26**

Flushing the pre-filters

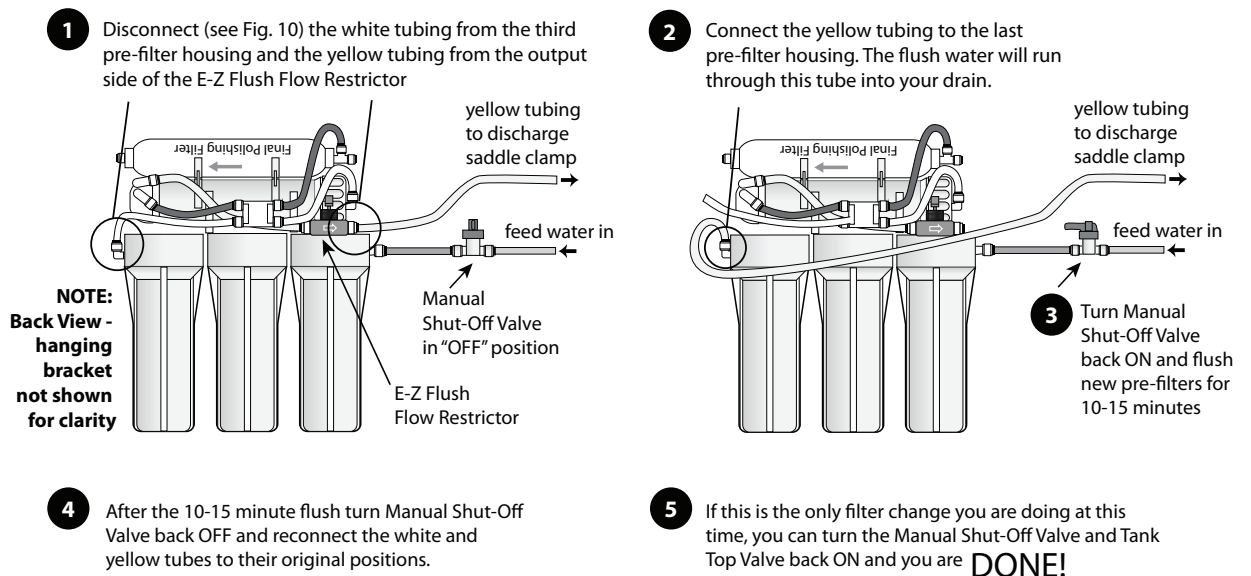

Congratulations. You have just completed a full change of your systems three pre-filters ensuring the purest of water for you and your family and the continued performance of your system.

## R.O. Membrane – How to change the R.O. Membrane of your system.

The fourth stage of your system is the Reverse Osmosis Membrane (Dow Filmtech Material R.O.) 0.00001 Micron. For your convenience, the Reverse Osmosis Membrane offered by Aquasafe will fit perfectly into any Reverse Osmosis System Aquasafe has offered in the past, currently does offer or will offer in the future.

Step 1. Depressurize your system. (see Fig. 23)

Step 2. Remove R.O. Membrane housing Cap (Fig. 27)

**Figure 27**

Removing the R.O. Membrane Housing cap

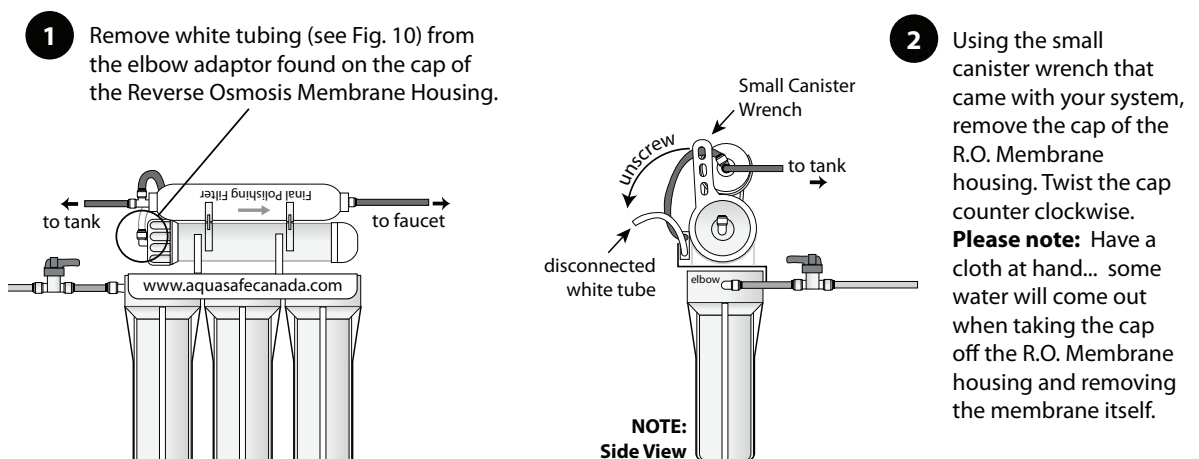

Step 3. Remove the old R.O. Membrane and inserting the new R.O. Membrane (Fig. 28)

**Figure 28**  
Removing the R.O. Membrane and inserting the new one

**1 Removing The Old Membrane:** You will now be able to see the Reverse Osmosis Membrane inside the R.O. Membrane Housing. The membrane can swell inside its housing making it difficult to remove by hand. Use a pair of needle nose pliers (or the like) to grab hold of the 1 inch white cylinder protruding from the base of the membrane and pull out the old R.O. Membrane.

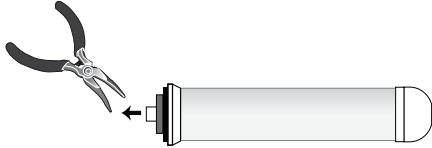

**2 Inserting the new R.O. Membrane:** Your R.O. Membrane comes sealed for freshness in a clear protective plastic. Remove your new membrane from its protective plastic. Insert your new R.O. Membrane into the R.O. Membrane housing of your system. The end of the R.O. Membrane that has the two small "O" rings gets inserted first.

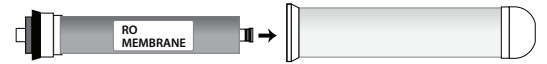
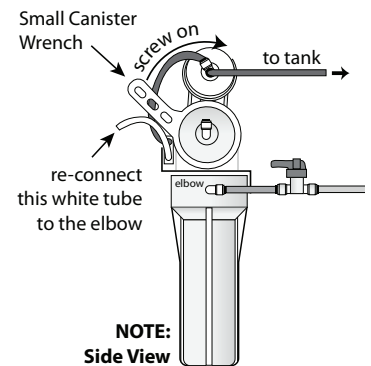

**Figure 29**  
Screw on the R.O. Membrane housing cap and re-insert the white tubing

**Please note:** The R.O. Membrane needs to be inserted as firmly as possible to ensure a proper seal is formed. For the R.O. Membrane to function properly it is extremely important for the two small "O" rings on the tip of the R.O. Membrane to seal properly inside the R.O. Membrane housing. To gain added leverage you can use a pair of needle nose pliers (or the like) to grab hold of the 1 inch white cylinder protruding from the base of the R.O. Membrane to push in and twist slightly. You will notice the membrane slip further into its housing forming the necessary seal described.

Next, screw the R.O. Membrane housing Cap back onto it place and reinsert the white tubing (Fig. 29).

Screw the R.O. Membrane housing cap back onto it place and reinsert the white tubing.



It is important to ensure ppm (parts per million) reduction rate of the purified water being produced by the R.O. Membrane. To do this you will need to use your TDS Meter.

**Please note:** If you do not have a TDS Meter we highly recommend you acquire one as it is the only way to verify the purity of the water the system is producing.

**Follow the instructions in Figure 26 to test your purified water.** It is important to note that your new R.O. Membrane comes saturated with food grade preservative so that it stays fresh and does not dry out and therefore it may take 3-5 minutes of purified (permeate) water flowing out of the blue tube to show the ppm reduction rates described in Fig. 24 and just after Fig. 24. If, after 15 minutes, you do not see the reductions rates as described it simply means your R.O. Membrane is not seated properly inside the R.O. Membrane housing and as such you will need to "re-seat" the R.O. Membrane. To do this simply follow the directions depicted above (Fig. 27 - 29) to remove and re-insert the same R.O. Membrane.

Step 4. Flush the new R.O. Membrane

If you are done replacing filters for now, you can re-pressurize your system by turning on the feed water line via the Manual Shut-Off Valve and turning the tank top valve back on. Your new R.O. Membrane comes saturated with food grade preservative so that it stays fresh and does not dry out and therefore it is wise to flush 2 tanks of water before you starting drinking the water from the new membrane. Allow the tank to fill and empty this down the drain via the faucet. Allow the tank to fill one more time and drain this as well. You can now enjoy your purified water once more. This concludes the steps to change the Reverse Osmosis Membrane of your system.

# Final Polishing Filter - How to change the Final Polishing Filter

This is the final filtration stage in your R.O. System. The Final Polishing filter is rated for 1800-2000 gallons of purified water production and therefore should be changed every second time you change your three pre-filters.

**Figure 30**  
Replacing the  
Final Polishing  
Filter

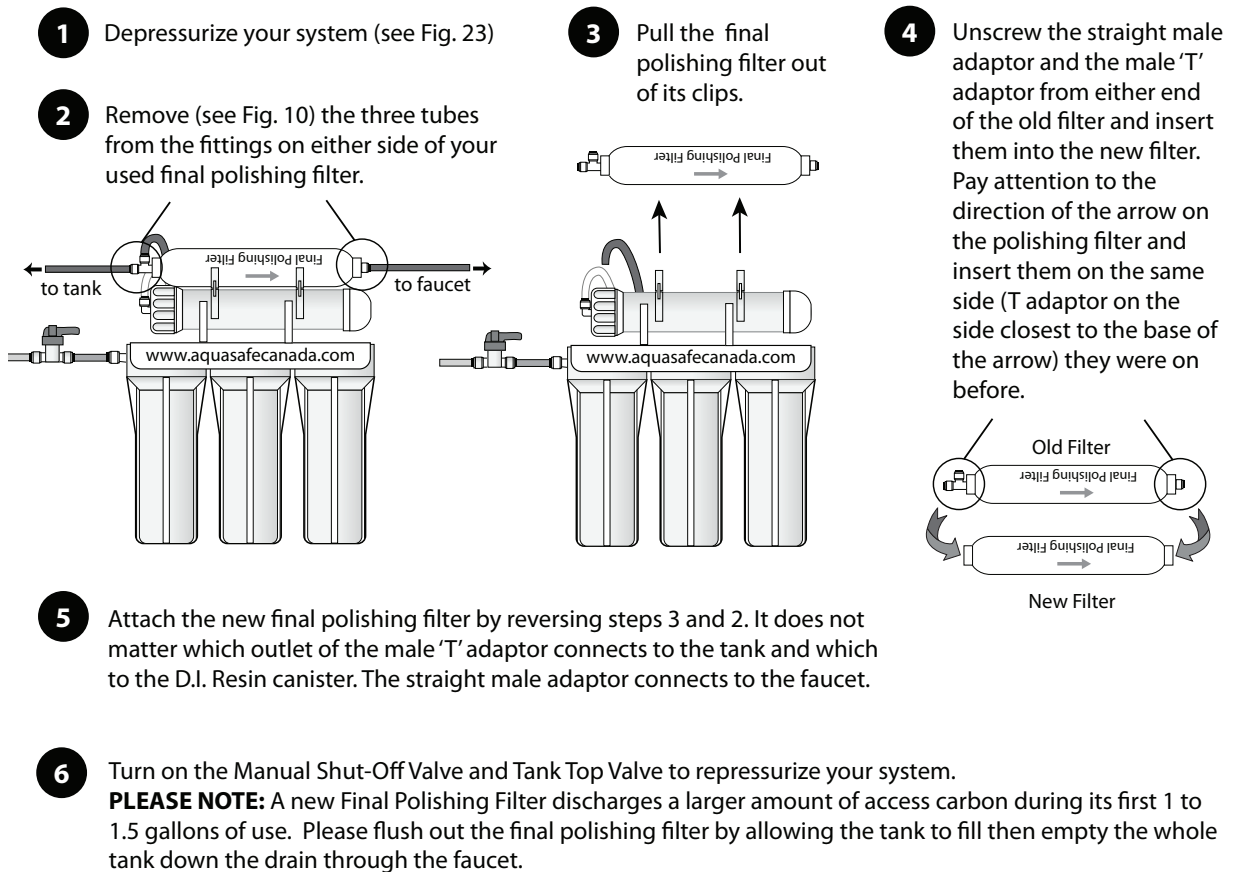

This concludes all filter change instructions for the Home II System. Please check on your system every hour after the filter change for the first three to four hours inspecting for any potential small leaks. If any drips are detected please see our Leak Prevention Page (page 15) which will explain how to quickly and easily fix all potential leaks.

Please do not hesitate to contact if you should need further assistance.

- Phone: (Toll Free) 1-888-942-0226
- Skype: Aquasafe
- Email: sales@aquasafecanada.com

Thank You for choosing Aquasafe Systems, we greatly value your business!

# WATER SYSTEMS & PARTS WARRANTY INFORMATION

## AQUASAFE'S THREE YEAR WARRANTY

All Aquasafe Water Filtration Systems are hereby warranted to be free from defects in material and workmanship for a full 3 years from the time of the original purchase, excluding the filtration media (IE Reverse Osmosis Filters, Reverse Osmosis Membranes, DI Resin Beards and other such media) as it is typical to change such media approx every 6 months. Any filter housings or adaptor fittings found to be defective will be replaced free of charge with all cost of shipping borne by Aquasafe. Any costs, labor and associated liability with removal or installation of the product for warranty consideration shall be borne by the purchaser. Please note that Aquasafe's Systems are designed as DIY (Do It Yourself), therefore there should not be any costs associated with removal or installation of the very simple to install and maintain Reverse Osmosis Systems that Aquasafe offers.

## FAUCET

Standard reverse osmosis faucets are replaced free for one full year. After which, the standard faucets can be replaced at any time for one-half the current retail price at time of replacement for life. Shipping costs for replacement Faucets shall be borne by the customer.

## PRE AND POST FILTER CARTRIDGES

Once used in a system, the Reverse Osmosis Pre and Post Filter Cartridges are non refundable. However if the structural integrity of a Pre and Post filter is found to be damaged upon delivery and before use in a system, a full 100% replacement will be sent with the cost of shipping being borne by Aquasafe. The structural problem must be made aware to Aquasafe no more than 30 days after delivery of product and all defective filters must be returned to Aquasafe.

## REVERSE OSMOSIS MEMBRANES

All Reverse Osmosis Membranes offered by Aquasafe come with a 1 year warranty. This warranty is void if any of the following has occurred or is not adhered to:

- The Membrane has been subject to improper flow restriction ratios. (please see the installation instructions pages for the proper setting of the flow restriction ratios)
- If the water temperature exceeds 113°F (45°C).
- The membrane is not subjected to a pH lower than 4 or higher than 11.
- The membrane is exposed to water pressure greater than 150 psi.
- The membrane is allowed to dry out after its initial wetting. (The Membrane should always be kept moist after its initial exposure to water)
- If the membrane is exposed to greater than 1500 PPM water

## BOOSTER PUMPS

Reverse Osmosis Booster Pumps are warranted for 90 days after the date of purchase. If for any reason there is dissatisfaction with the purchase of a booster pump within the 90 day period, a 100% refund of the purchase price will be issued. The cost of returning the product will be borne by the purchaser and the refund will be made when the product is returned to Aquasafe.

## WARRANTY CONDITIONS

•Shipping costs to and from the company, of products to be considered for warranty, shall be borne by the purchaser unless otherwise specified in the warranty conditions listed above.

- Any costs associated with removal or installation of the product for warranty consideration shall be borne by the purchaser. Please

note that Aquasafe's Reverse Osmosis Systems are designed as DIY (Do It Yourself), therefore there should not be any costs associated with removal or installation of this very simple to install system.

- This warranty does not apply to mechanical or structural damage caused by: excessive water pressures over 150 psi, improper handling, installation or abuse.
- Faucets and water filtration valves are warranted for a period of one year only unless otherwise specified. This warranty applies to manufacturing/material defects only.
- All replaceable water filtration cartridges are warranted to be free from breakage/damage at the time delivery only.
- This warranty does not apply to any part or component that has been subject to misuse, neglect or altered in any such way that its performance is affected.
- The company "Aquasafe" accepts no liability for damage caused in any way by the product after installation. The product should be closely monitored after initial installation and installed in accordance with plumbing codes in your area when and where applicable.
- Water filtration system installation instructions are provided online. These instructions are as a guide to the installer only and do not supersede the plumbing codes in your respective areas when and where applicable. Containment of these instructions does not conclude that the Company promotes or endorses self-installation, and no liability will be assumed by the company for the installation.
- No person, representative or firm is authorized to commit Aquasafe Systems to any further liability or obligation than those stated on this form.

## GENERAL CONDITIONS of WARRANTY

Damage to any part of a reverse osmosis system because of misuse; misapplication; negligence; alteration; accident; installation; or operation contrary to our instructions, incompatibility with accessories not provided by Aquasafe, or damage caused by freezing, flood, fire, or Act of God, is not covered by this warranty. In all such cases, regular charges will apply. This warranty is void if the claimer is not the original purchaser of the unit or if the unit is not operated under normal municipal water or well water conditions.

We assume no warranty liability in connection with this reverse osmosis system other than that specified herein. This warranty is in lieu of all other warranties, expressed or implied, including warranties of fitness for a particular purpose. We do not authorize any person or representative to assume for us any other obligations on the sale of this reverse osmosis system. Behind this product are years of research, design, and production skills. Our reverse osmosis drinking water systems have been carefully tested and approved. Through this warranty we are demonstrating our confidence in Aquasafe's water filters and the quality our customers have come to expect from our 18+ years in business providing the finest quality drinking water at pennies per liter for the health and enjoyment of our long history of customers.

There has never been a greater need to be absolutely sure the water we are consuming and giving to our children is free of all contaminants, toxins and drugs. The very best and most affordable way to ensure you and your loved ones are getting pure and healthy drinking water is with a water purification system from Aquasafe.

Make the choice to avoid all dangers of tap water and its health hazards by getting your very own reverse osmosis system today !