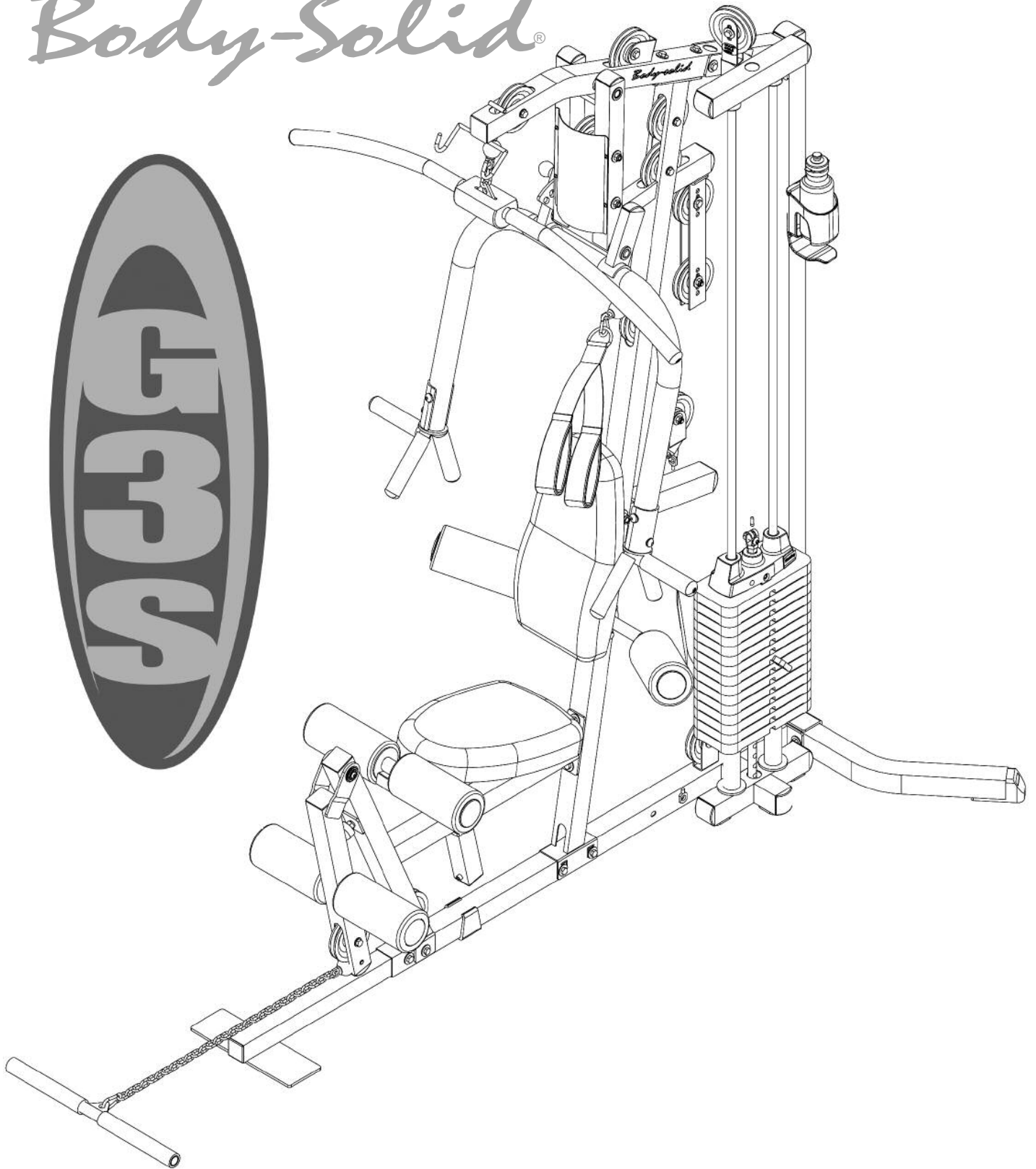


*Body-Solid*<sup>®</sup>



**A s s e m b l y**

**I n s t r u c t i o n s**

**STEP****1**

**Be careful to assemble all components in the sequence they are presented.**

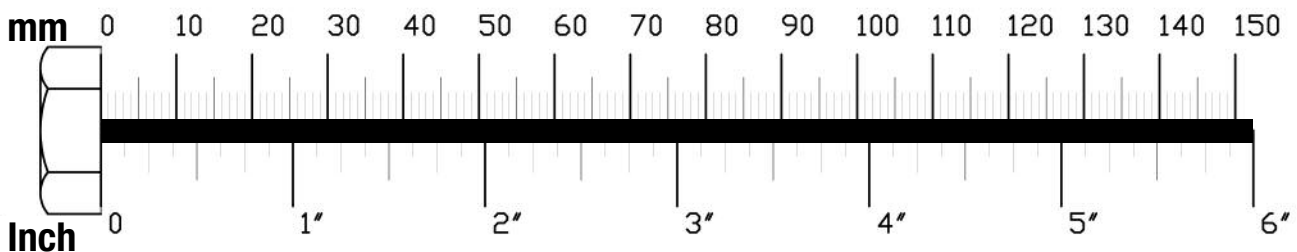
**NOTE:**

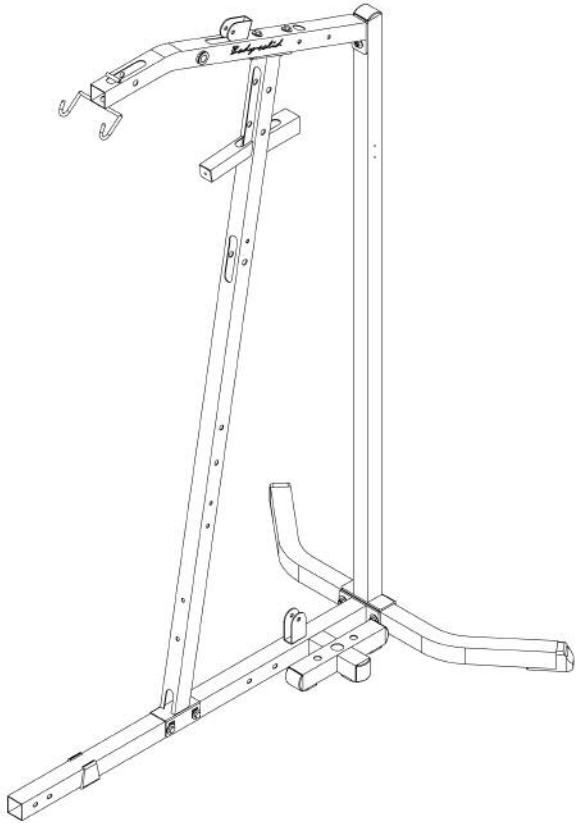
**Finger tighten all hardware in this step. Do Not wrench tighten until end of step 4.**

- A. Attach Frame Leveler (8) to Main Base Frame (A) as shown.  
Attach Main Base Frame (A) to Rear Base Frame (B) and Rear Vertical Frame (C) using:  
**Two 43 (3/8" x 2 3/4" hex head bolt)**  
**Two 55 (3/8" washer)**  
**Two 51 (3/8" nylon lock nut)**  
**and**  
**Two 63 (3/8" x 2 3/4" carriage bolt)**  
**Two 51 (3/8" nylon lock nut)**
- B. Attach three End Caps (4) to Main Base Frame (A).  
Attach two Foot Caps (6) to the ends of Rear Base Frame (B).  
Attach End Cap (4) to the top of Rear Vertical Frame (C).
- C. Attach Angled Vertical Frame (D) to Main Base Frame (A) using:  
**Two 43 (3/8" x 2 3/4" hex head bolt)**  
**Two 51 (3/8" nylon lock nut)**
- D. Attach Top Frame (E) and Flat Plate (70) to Angled Vertical Frame (D) using:  
**Two 42 (3/8" x 3" hex head bolt)**  
**Two 51 (3/8" nylon lock nut)**
- E. Connect Top Frame (E) and Flat Plate (65) to Rear Vertical Frame (C) using:  
**Two 62 (3/8" x 2 1/2" hex head bolt)\***

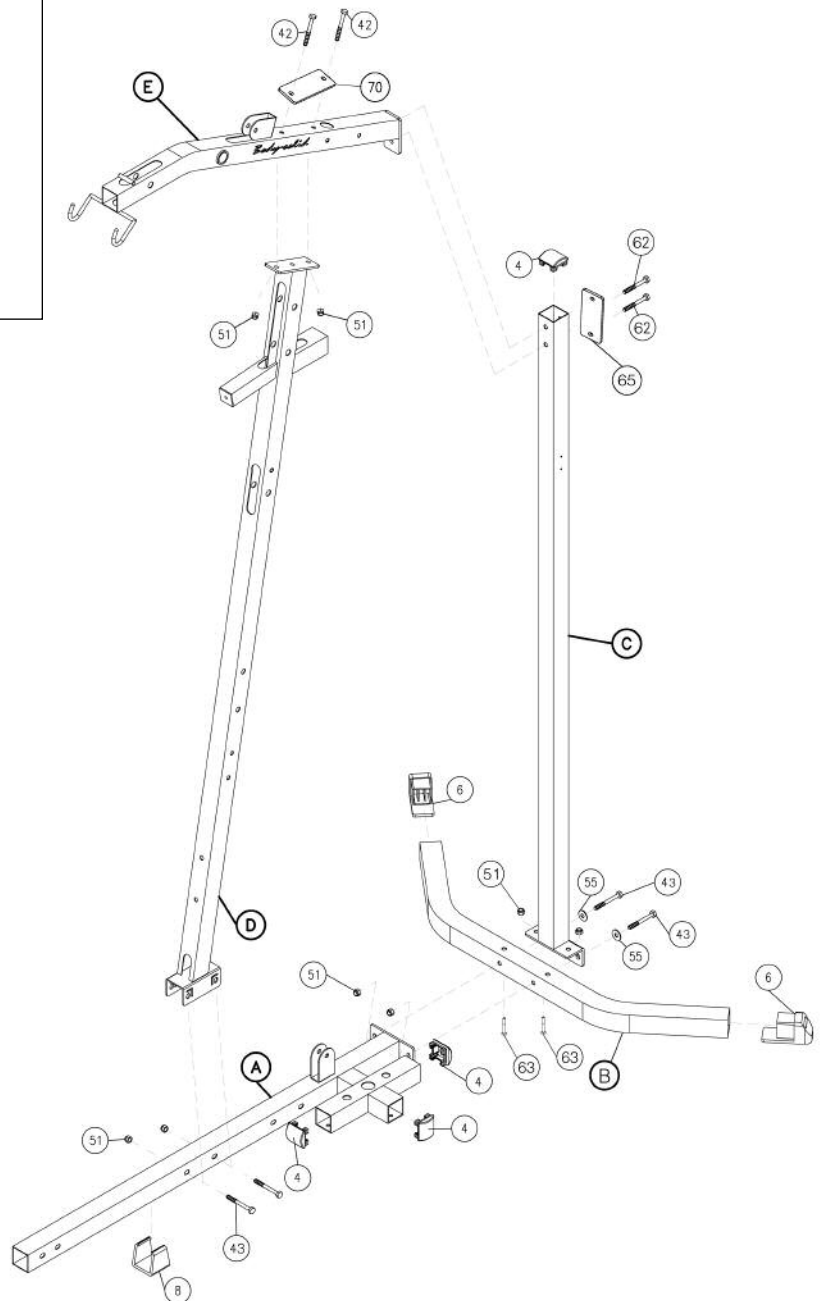
**\*Note:**

**Hex head bolts (62) go into threaded housing inside Top Frame (E)**





Above shows STEP 1 assembled and completed.



**STEP****2**

**Be careful to assemble all components in the sequence they are presented.**

**NOTE:**

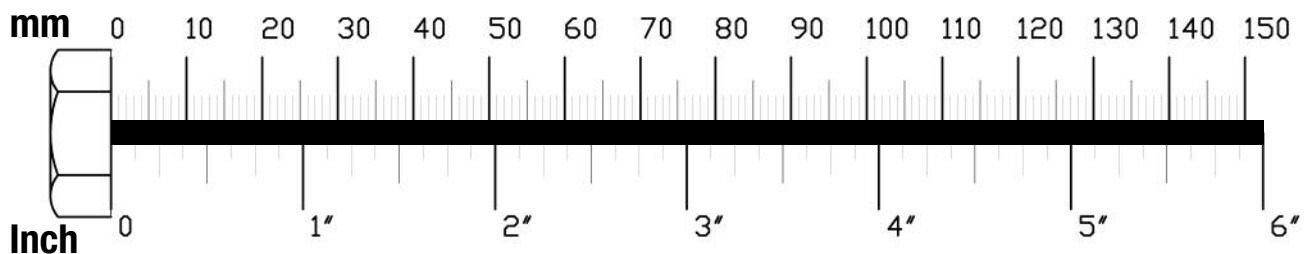
**Finger tighten all hardware in this step. Do Not wrench tighten until end of step 4.**

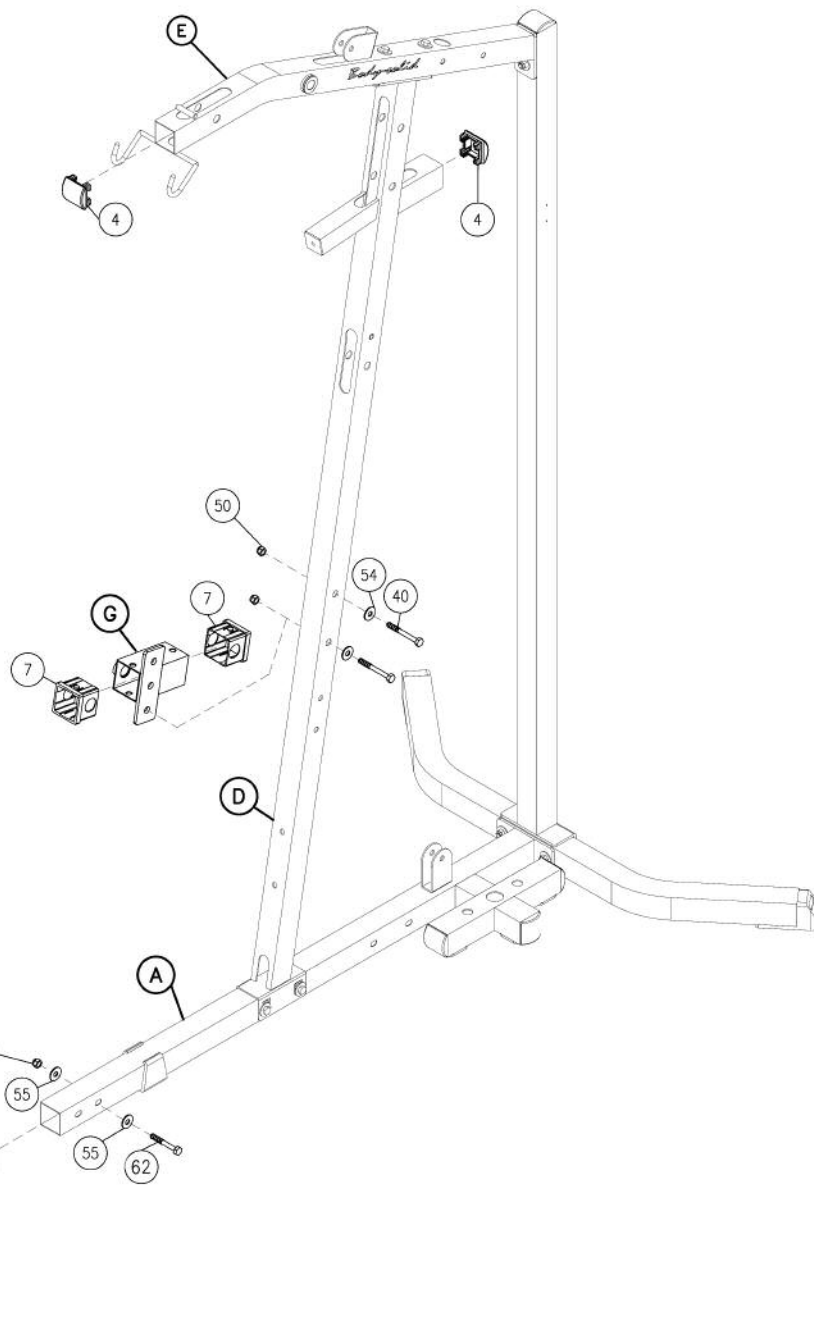
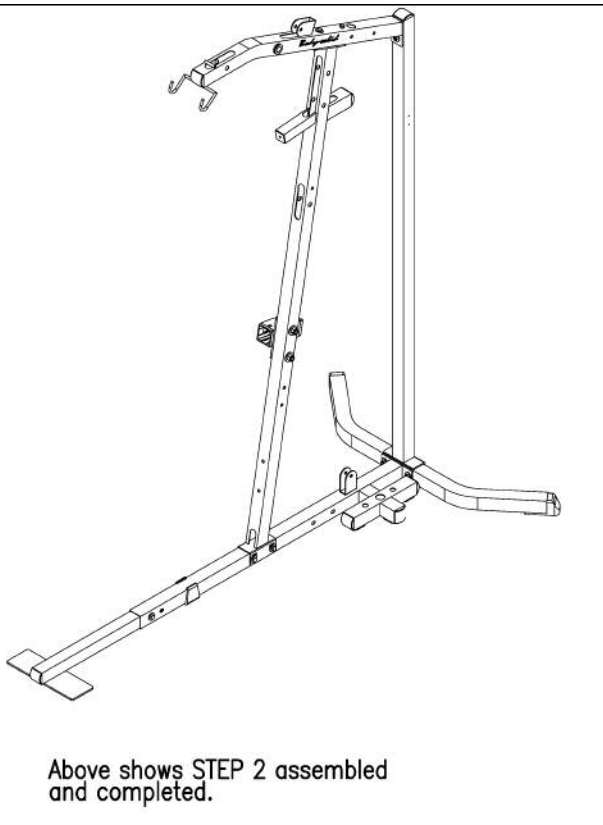
- A. Attach one End Cap (4) to the front of Top Frame (E).  
Attach one End Cap (4) to the small horizontal arm sticking out of the Angled Vertical Frame (D) as shown.
- B. Attach Front Frame (F) to Main Base Frame (A) using:  
**One 62 (3/8" x 2 1/2" hex head bolt)\***  
**Two 55 (3/8" washer)**  
**One 51 (3/8" nylon lock nut)**  
Attach Flat End Cap (2) into the opening in the Front Frame (F).

**\*NOTE:**

**Only use one bolt (62) as shown. You will need the other hole open for step 3.**

- C. Insert two Thin Nylon Bushings (7) into Back Pad Adjuster (G).  
Attach Back Pad Adjuster (G) to Angled Vertical Frame (D) using:  
**Two 40 (1/2" x 3" hex head bolt)**  
**Two 54 (1/2" washer)**  
**Two 50 (1/2" nylon lock nut)**

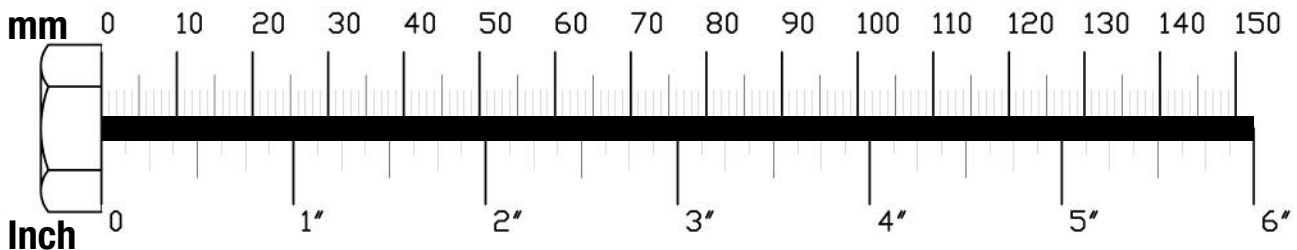




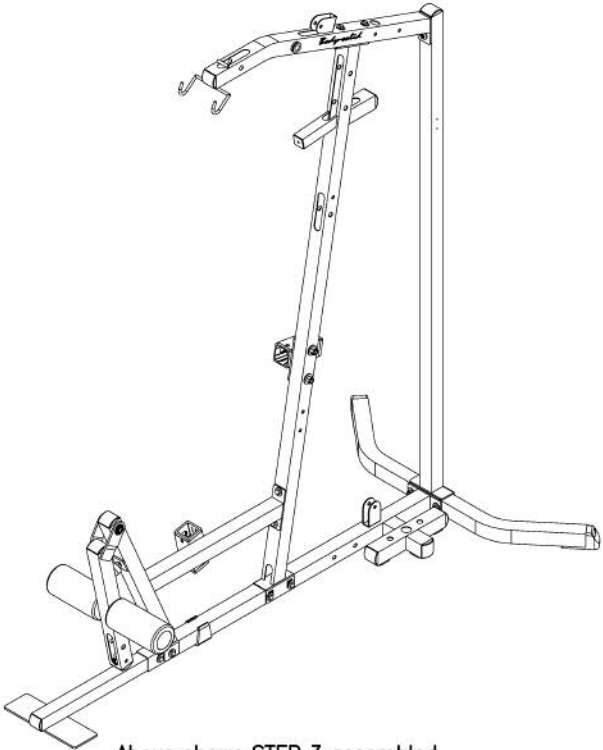
**STEP****3****Be careful to assemble all components in the sequence they are presented.****NOTE:**

**Finger tighten all hardware in this step. Do Not wrench tighten until end of step 4.**

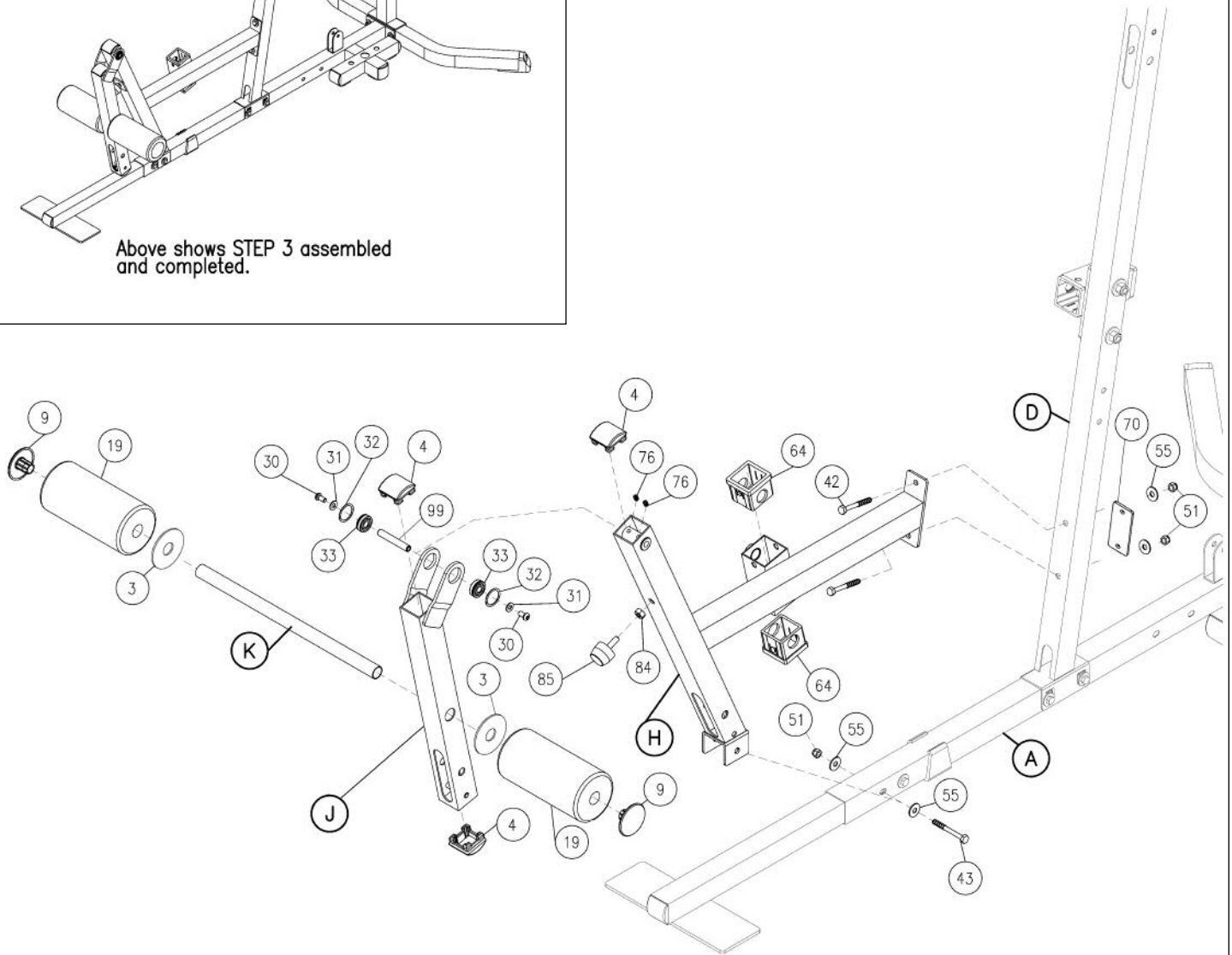
- A. Attach Seat Frame (H) and Flat Plate (70) to Angled Vertical Frame (D) using:  
**Two 42 (3/8" x 3" hex head bolt)**  
**Two 55 (3/8" washer)**  
**Two 51 (3/8" nylon lock nut)**
- B. Attach Seat Frame (H) to Main Base Frame (A) using:  
**One 43 (3/8" x 2 3/4" hex head bolt)**  
**Two 55 (3/8" washer)**  
**One 51 (3/8" nylon lock nut)**
- C. Insert two Thick Nylon Bushing (64) into Seat Frame (H) as shown.
- D. Attach Leg Extension (J) to Seat Frame (H) with the pre-installed Shaft (99) as shown, and using:  
**Two 30 (1/4" x 9/16" allen bolt)**  
**Two 31 (1/4" washer)**  
Tighten the two Allen Screws (76) in Seat Frame (H) to lock down Shaft (99).  
Insert one End Cap (4) into Seat Frame (H) as shown.
- E. Attach two Foam Rollers (19) to Leg Extension (J) using Foam Roller Bar (K) and two 1" Round End Cap (9) as shown.  
Insert Two End Cap (4) into Leg Extension (J) as shown.
- F. Check to make sure Rubber Stop (85) and Jam Nut (84) are attached to Seat Frame (H) as shown.



**STEP**  
**3**



Above shows STEP 3 assembled and completed.



**STEP****4**

**Be careful to assemble all components in the sequence they are presented.**

- A. Place two Weight Stack Risers (27) and two Rubber Donuts (11) onto Main Base Frame (A) over the two widest openings. Slide two Chrome Guide Rods (M) through the Rubber Donuts (11), two Weight Stack Risers (27), and into Main Base Frame (A).
- B. Slide fifteen Weight Stack Plates (26) onto the two Chrome Guide Rods (R). Make sure the holes in the Weight Stack Plates (26) are facing forward as shown.
- C. Connect Top Plate (20) to Selector Rod (21) using:  
**One 46 (3/8" x 1 1/2" socket head bolt)**
- D. Slide Top Plate (20) and Selector Rod (21) onto Guide Rods (M).

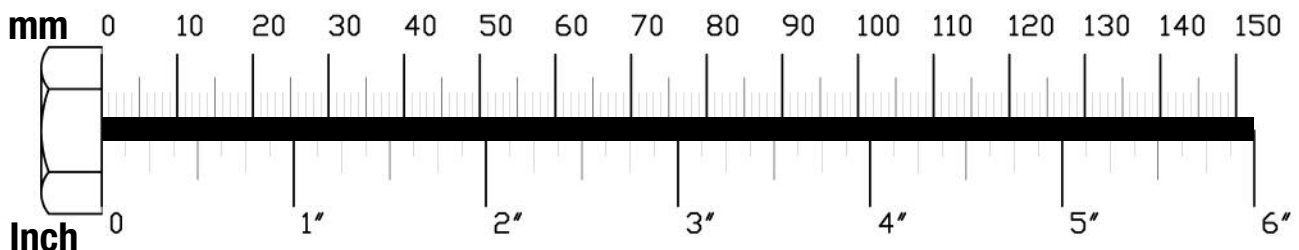
**NOTE:**

**Make sure that the Round Bolt (46) is facing forward as shown.**

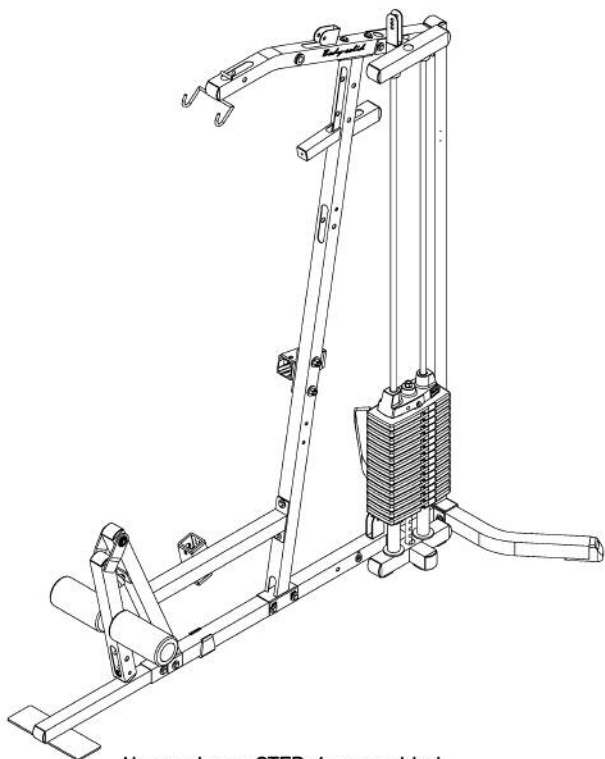
- E. Slide two Shaft Collars (13) onto Guide Rods (M).
- F. Insert two Guide Rods (M) into Top Weight Stack Frame (N). Attach Top Weight Stack Frame (N) and Flat Plate (70) to Top Frame (E) using:  
**Two 42 (3/8" x 3" hex head bolt)**  
**Two 51 (3/8" nylon lock nut)**  
Insert two End Caps (4) into the sides of the Top Weight Stack Frame (N) as shown.
- G. Secure two Shaft Collars (13) into Top Weight Stack Frame (N). Tighten allen head screws in each Shaft Collar (13).

**NOTE:**

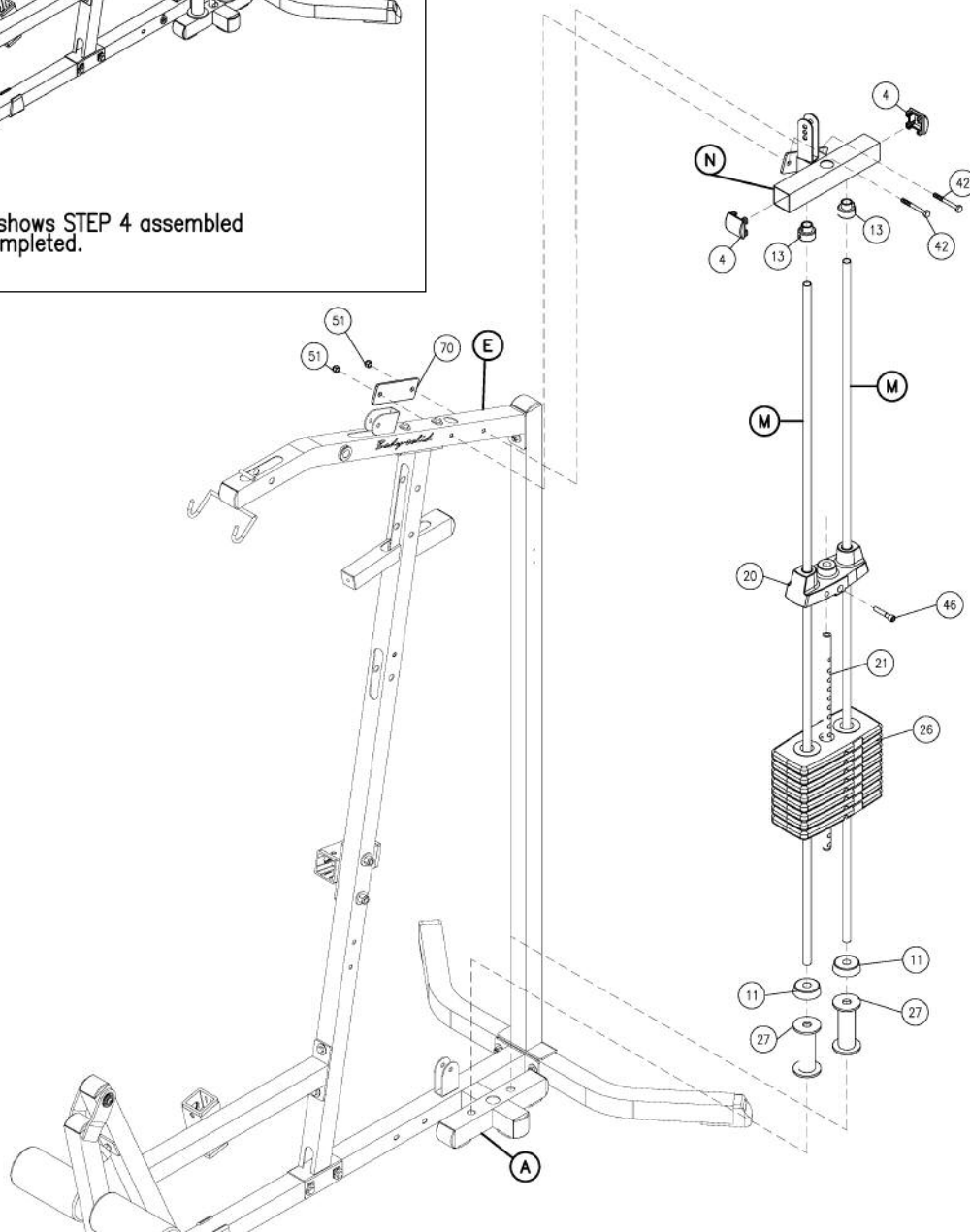
**You should now wrench tighten all bolts and nuts on the main frame unit.**







Above shows STEP 4 assembled and completed.



**STEP****5**

**Be careful to assemble all components in the sequence they are presented.**

**NOTE:**

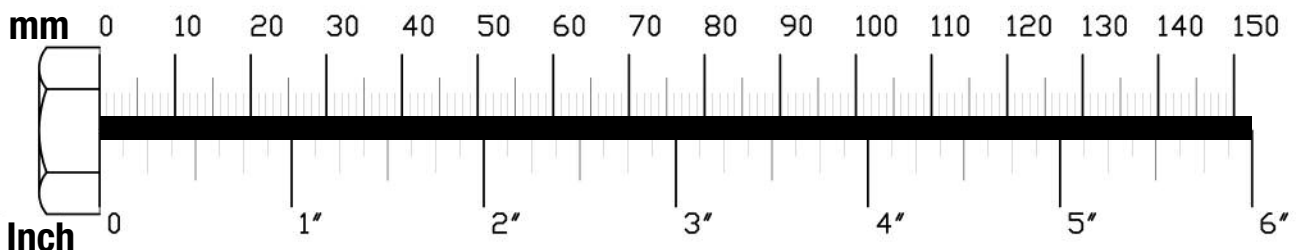
**You will need to loosen two Allen Screws (76) inside Seated Press Arm Support (P) to remove Shaft (71)**

- A. Attach Seated Press Arm Support (P) to Top Frame (E) with Shaft (71). Tighten Allen Screws (76) in Seated Press Arm Support (P). Oilite Bushings (74) are pre-installed.

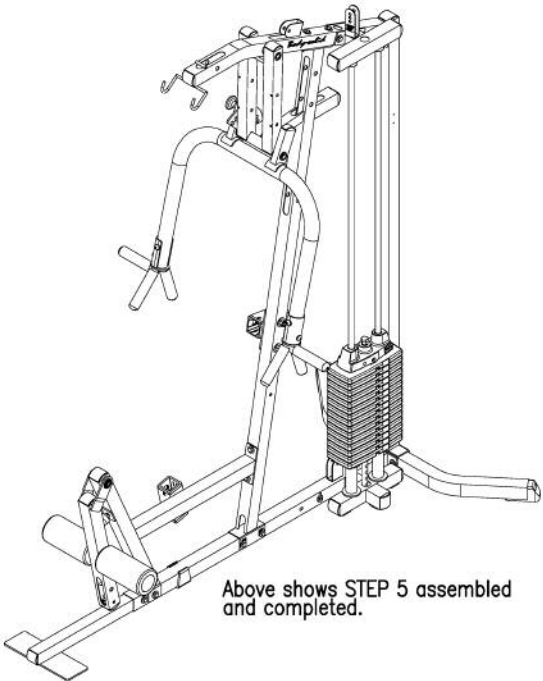
**NOTE:**

**You will need to loosen two Allen Screws (76) inside Seated Press Arms (Q) to remove Shaft (72)**

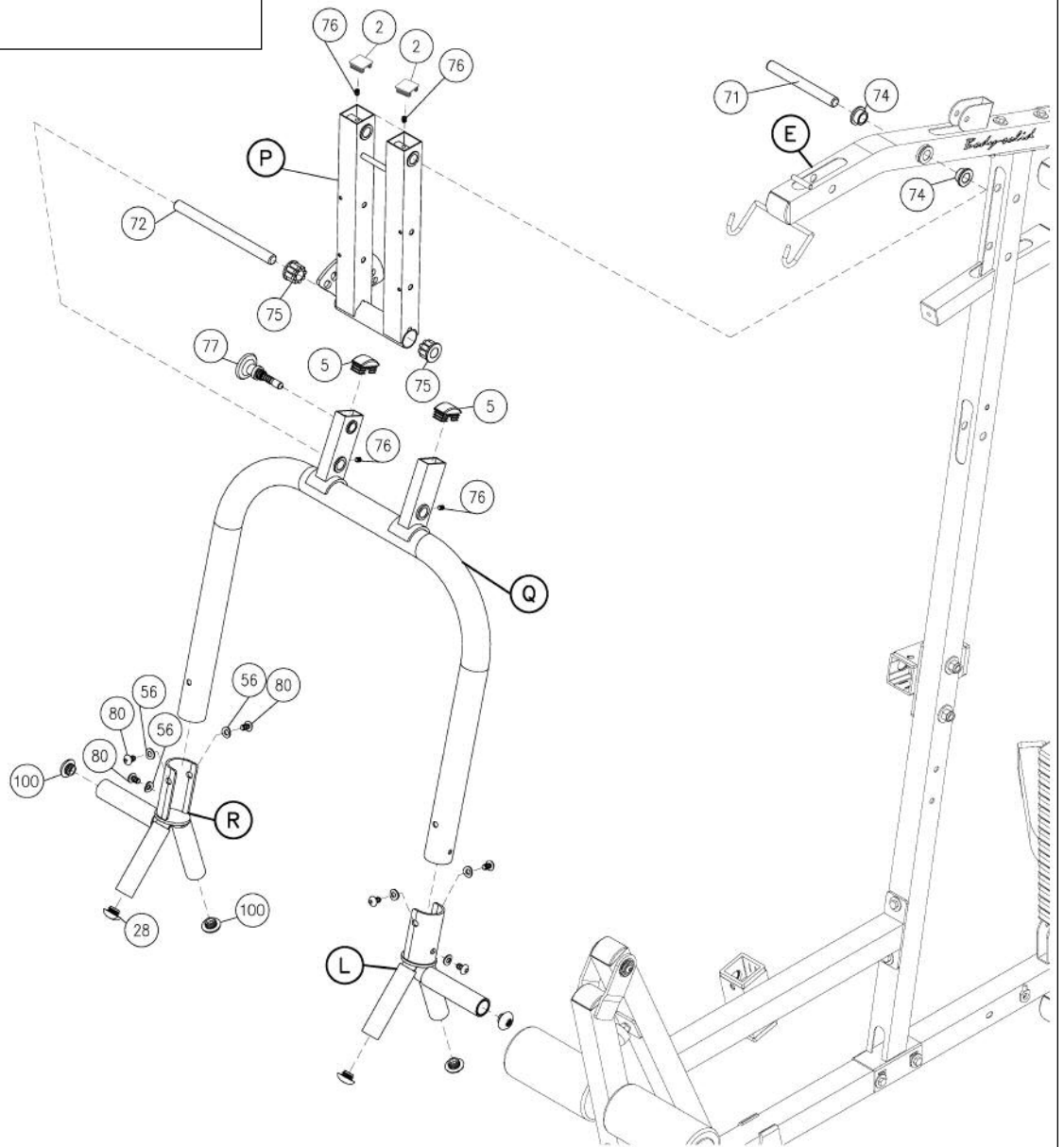
- B. Attach Seated Press Arms (Q) to Seated Press Arm Support (P) with Shaft (72). Tighten Allen Screws (76) inside Seated Press Arms (Q). Plastic Bushings (75) are pre-installed. Make sure Pop Pin (77) in Seated Press Arms (Q) is fully engaged into selector hole in Seated Press Arm Support (P).
- C. Attach two Flat End Caps (2) to the top of the Seated Press Arm Support (P). Attach two End Caps (5) to the top of the Seated Press Arm (Q).
- D. Attach the Right Seated Press Handle (R) to the Seated Press Arm (Q) as shown using:  
**Three 80 (3/8" x 5/8" allen bolt)**  
**Three 56 (3/8" curved washer)**  
Tighten the three Allen Bolts (80).  
Insert two Round End Caps (100) and one Small Round End Cap (28) into Right Seated Press Handle (R) as shown.
- E. Attach the Left Seated Press Handle (L) to the Seated Press Arm (Q) as shown using:  
**Three 80 (3/8" x 5/8" allen bolt)**  
**Three 56 (3/8" curved washer)**  
Tighten the three Allen Bolts (80).  
Insert two Round End Caps (100) and one Small Round End Cap (28) into Left Seated Press Handle (L) as shown.



**STEP**  
**5**



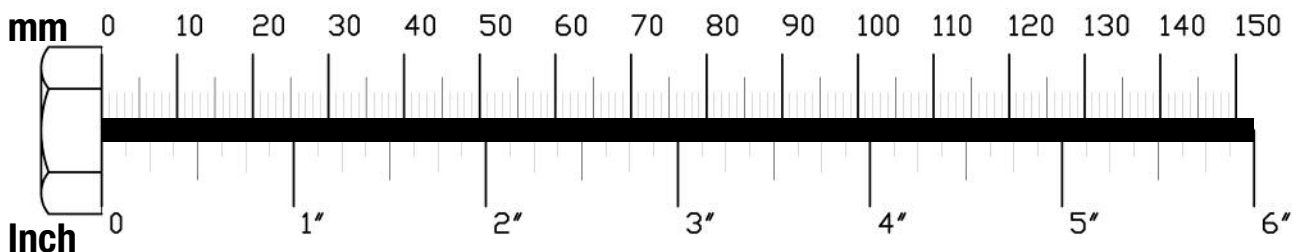
Above shows STEP 5 assembled and completed.

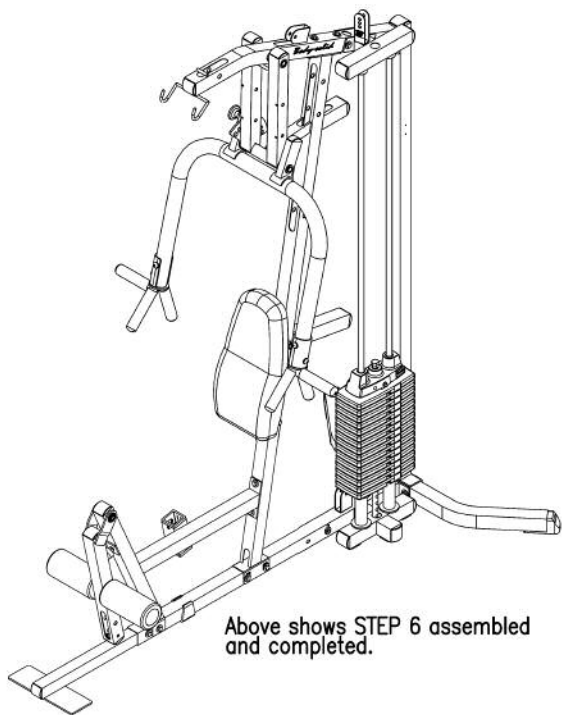


**STEP****6**

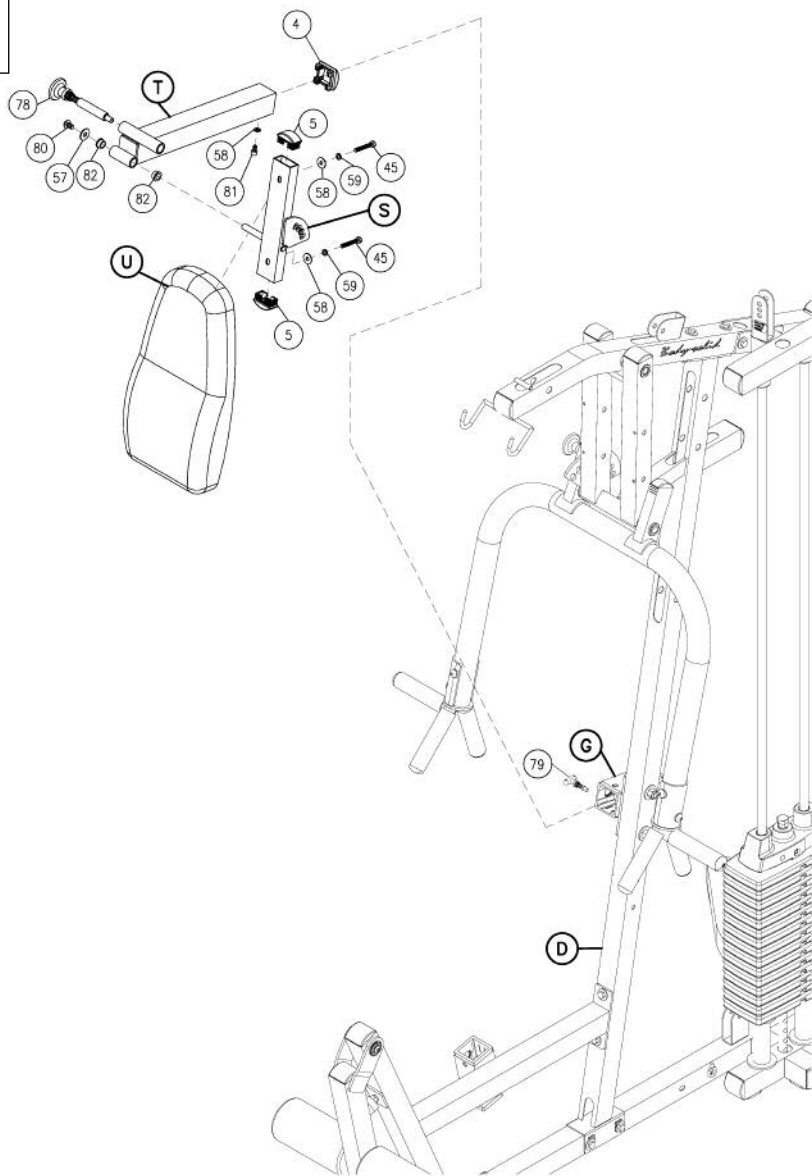
**Be careful to assemble all components in the sequence they are presented.**

- A. Attach two End Caps (5) to the top and bottom of Back Pad Frame (S).  
Attach End Cap (4) to the end of Adjustable Back Pad Frame (T).
- B. Attach Back Pad (U) to Back Pad Frame (S) using:  
**Two 45 (5/16" x 1 3/4" hex head bolt)\***  
**Two 59 (5/16" spring lock washer)**  
**Two 58 (5/16" washer)**  
**\*Do NOT over-tighten these bolts. Tighten these bolts until spring lock washer is flat.**  
**Over - tightening these bolts will cause T - nuts in pads to strip out.**
- C. Attach Back Pad Frame (S) to Adjustable Back Pad Frame (T) using:  
**One 80 (3/8" x 5/8" round allen head bolt)\***  
**One 57 (3/8" x 3/4" O.D. washer)**  
Insert Pop Pin (78) as shown. Two Oilite Bushings (82) are pre-installed.  
\*Tighten allen bolt.
- D. Slide Adjustable Back Pad Frame (T) into Back Pad Adjuster (G), and hold in place with Pop Pin (79).





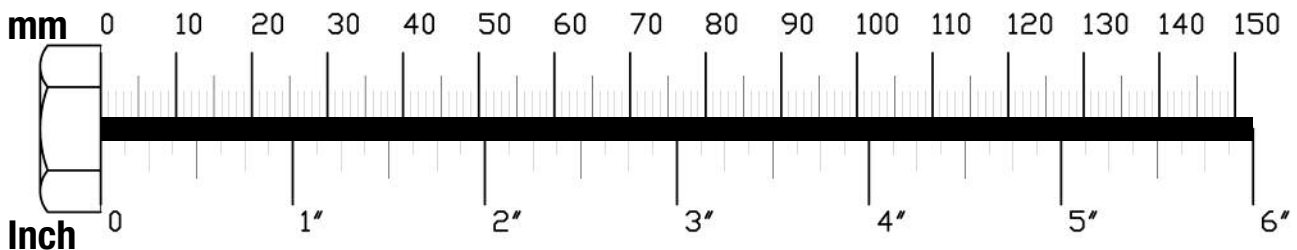
Above shows STEP 6 assembled and completed.



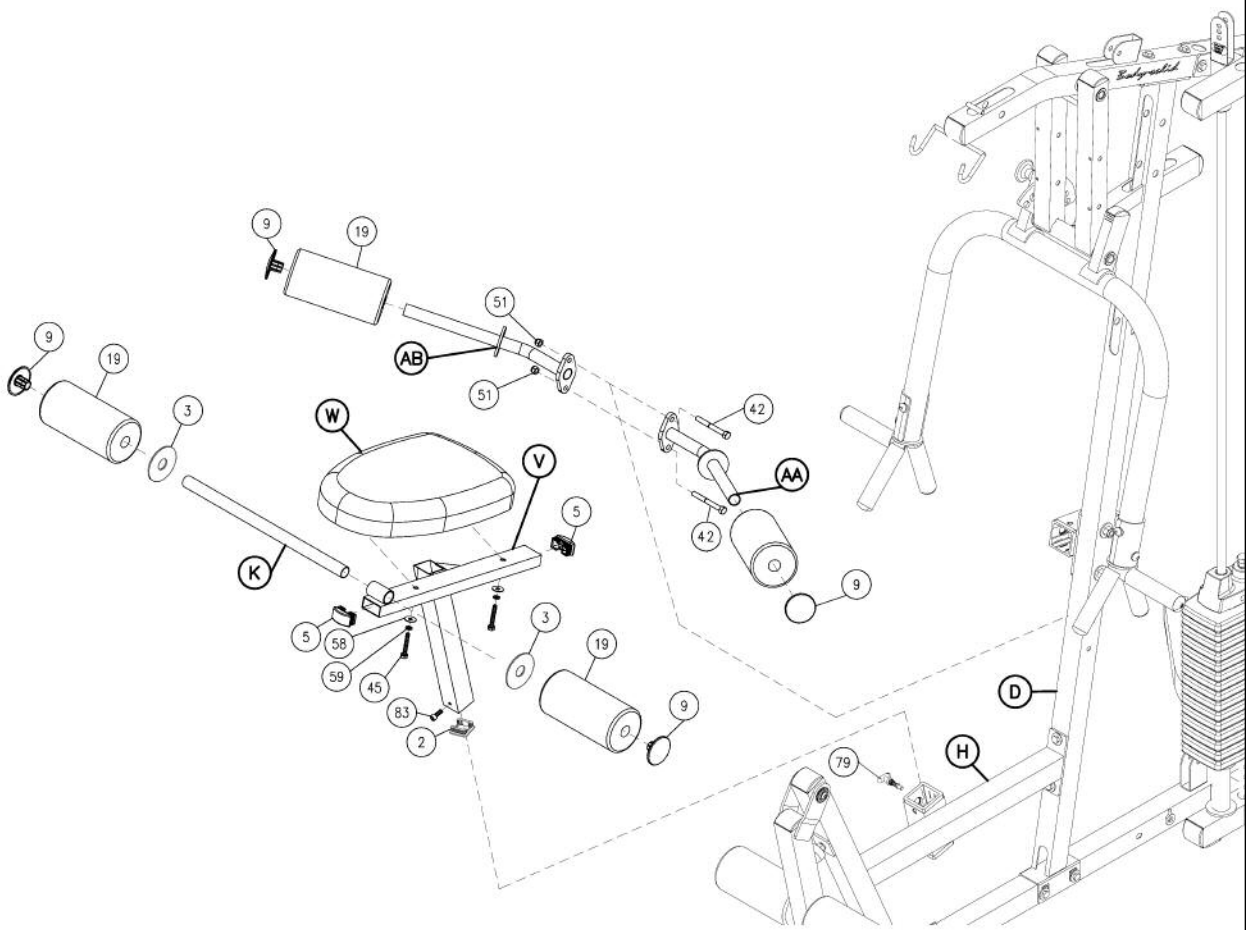
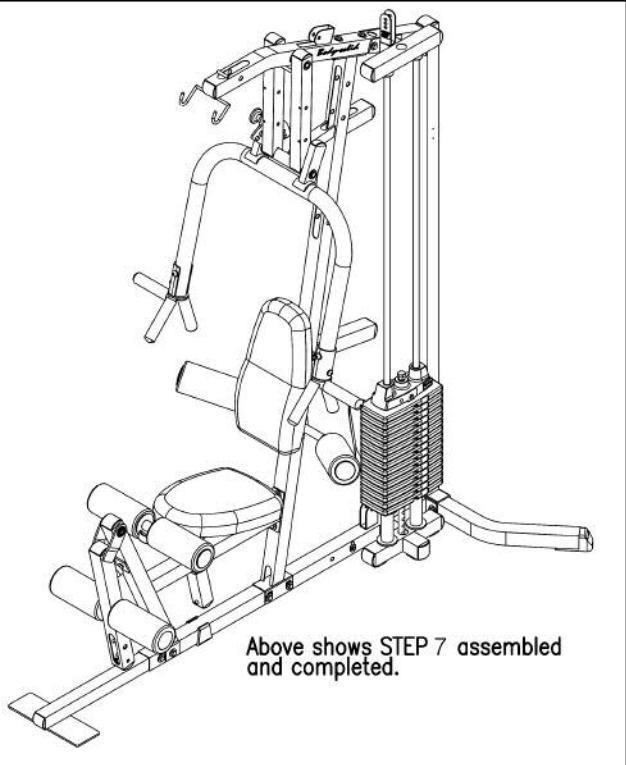
**STEP****7**

**Be careful to assemble all components in the sequence they are presented.**

- A. Attach Flat End Cap (2) to the bottom of the Adjustable Seat Pad Frame (V).  
Attach two End Caps (5) to the front and back of the Adjustable Seat Pad Frame (V).
- B. Attach Seat Pad (W) to the Adjustable Seat Pad Frame (V) using:  
**Two 45 (5/16" x 1 3/4" hex head bolt)\***  
**Two 59 (5/16" spring lock washer)**  
**Two 58 (5/16" washer)**  
**\*Do NOT over-tighten these bolts. Tighten these bolts until spring lock washer is flat.**  
**Over - tightening these bolts will cause T - nuts in pads to strip out.**
- C. Slide Adjustable Seat Pad Frame (V) into Seat Pad Frame (H), and hold in place with Pop Pin (79).
- D. Attach two Foam Rollers (19) to the front of the Adjustable Seat Pad Frame (V) using Foam Roller Shaft (K) and two 1" Round End Cap (9) as shown.
- E. Attach Left Leg Hold Down (AA) and Right Leg Hold Down (AB) to Angled Vertical Frame (D) using:  
**Two 42 (3/8" x 3" hex head bolt)\***  
**Two 51 (3/8" nylon lock nut)**  
**\*Tighten these two 3/8" bolts.**
- F. Attach two Foam Rollers (19) to Left Leg Hold Down (AA) and Right Leg Hold Down (AB) and hold on with 1" Round End Cap (9) as shown.



**STEP**  
**7**



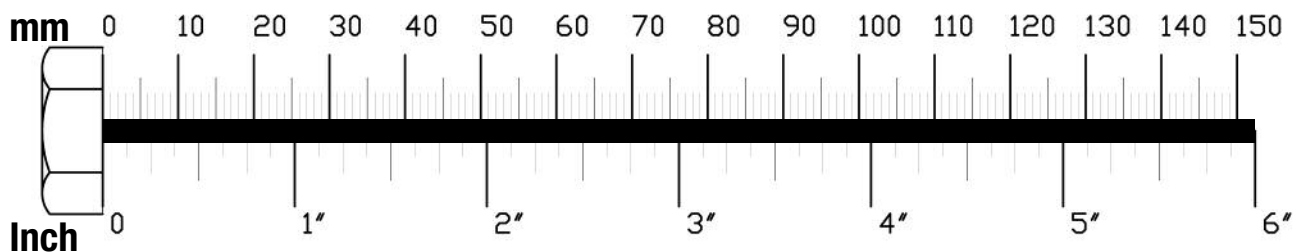
**STEP****8**

**Be careful to assemble all components in the sequence they are presented.**

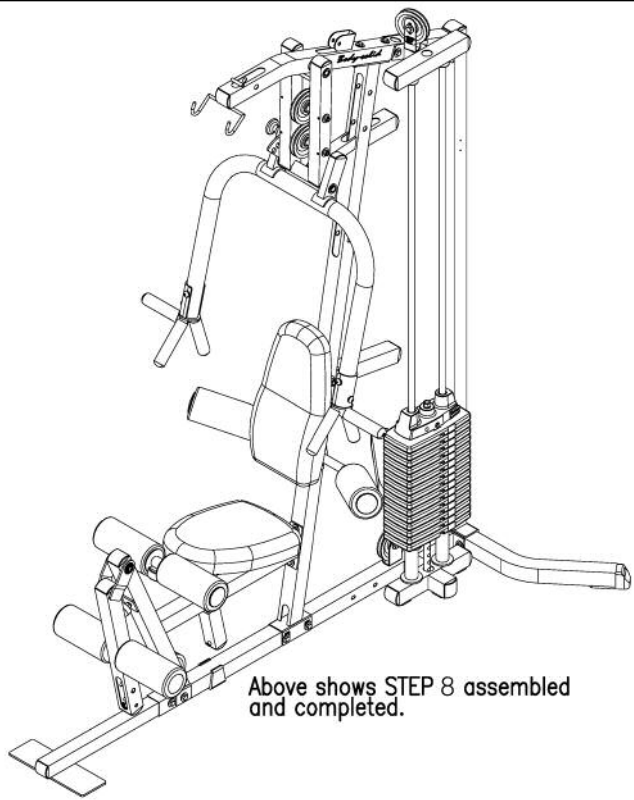
**NOTE:**

**Leave all pulley bolts hand tight until step 13**

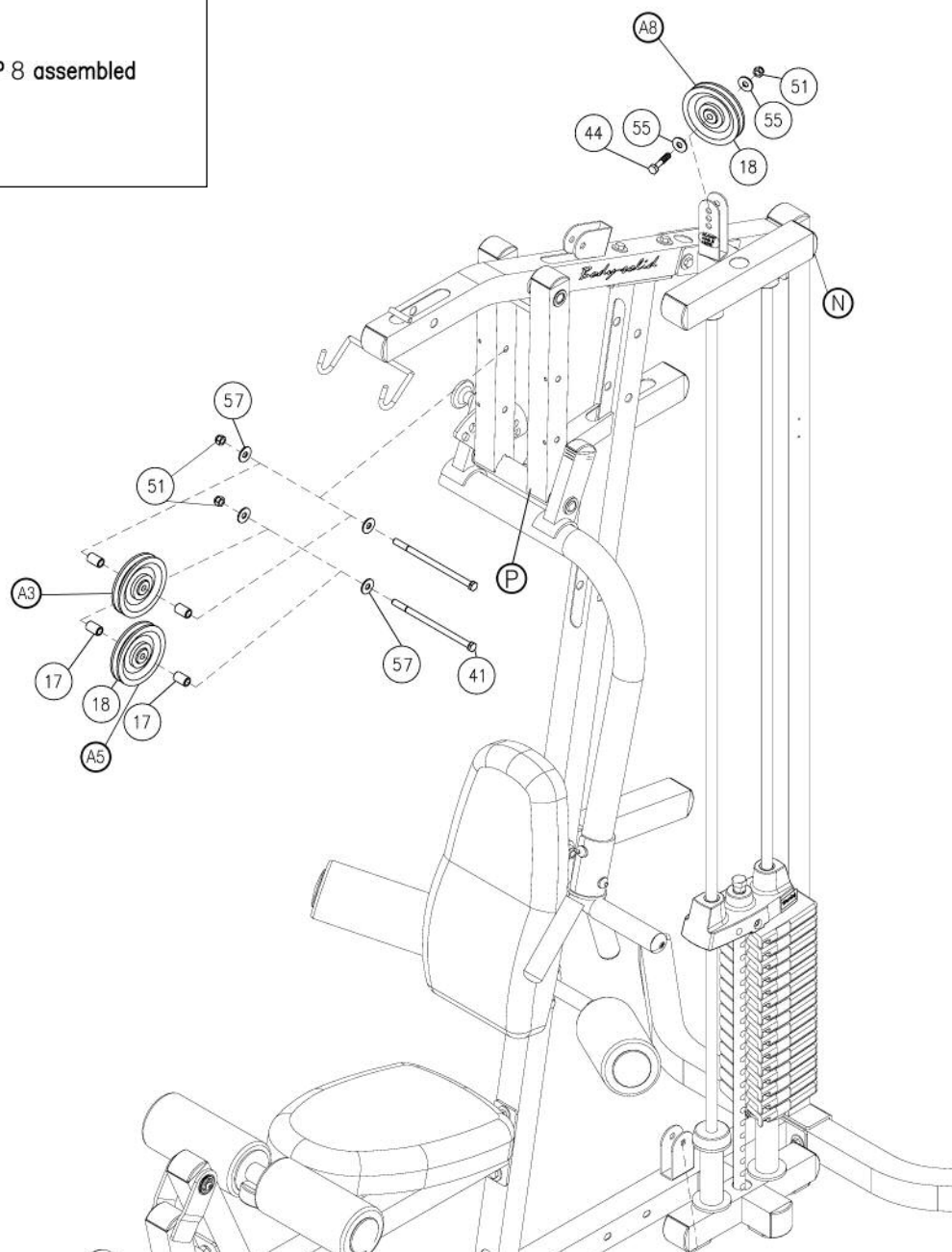
- A. Install Pulley (A3) into Seated Press Arm Support (P) as shown using:  
**One 41 (3/8" x 7" hex head bolt)**  
**Two 57 (3/8" washer x 3/4" o.d.)**  
**Two 17 (spacer sleeve)**  
**One 51 (3/8" nylon lock nut)**
- B. Install Pulley (A5) into Seated Press Arm Support (P) as shown using:  
**One 41 (3/8" x 7" hex head bolt)**  
**Two 57 (3/8" washer x 3/4" o.d.)**  
**Two 17 (spacer sleeve)**  
**One 51 (3/8" nylon lock nut)**
- C. Install Pulley (A8) into the pulley flange on Top Weight Stack Frame (N) as shown using:  
**One 44 (3/8" x 1 3/4" hex head bolt)**  
**Two 55 (3/8" washer)**  
**One 51 (3/8" nylon lock nut)**





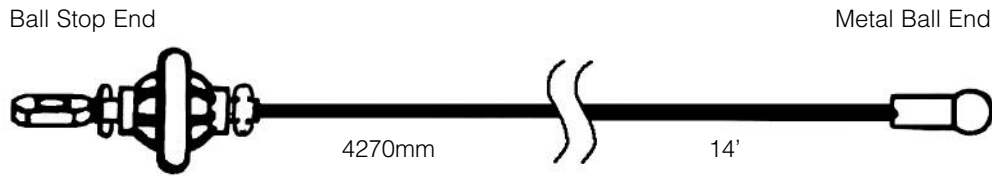


Above shows STEP 8 assembled and completed.



**Be careful to assemble all components in the sequence they are presented.**

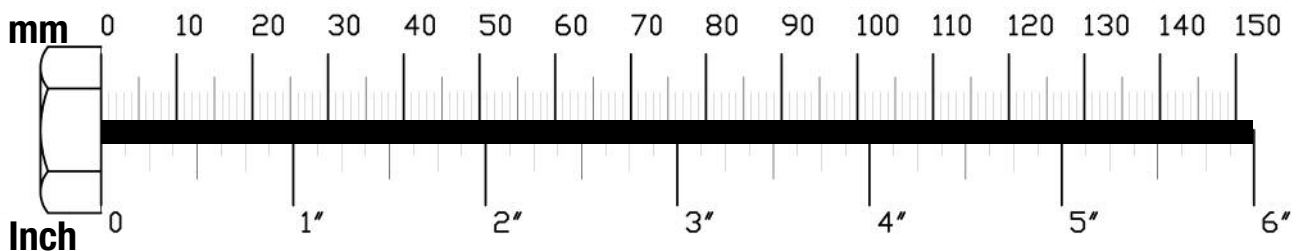
### **High Pulley Cable (66)**



**Note:**

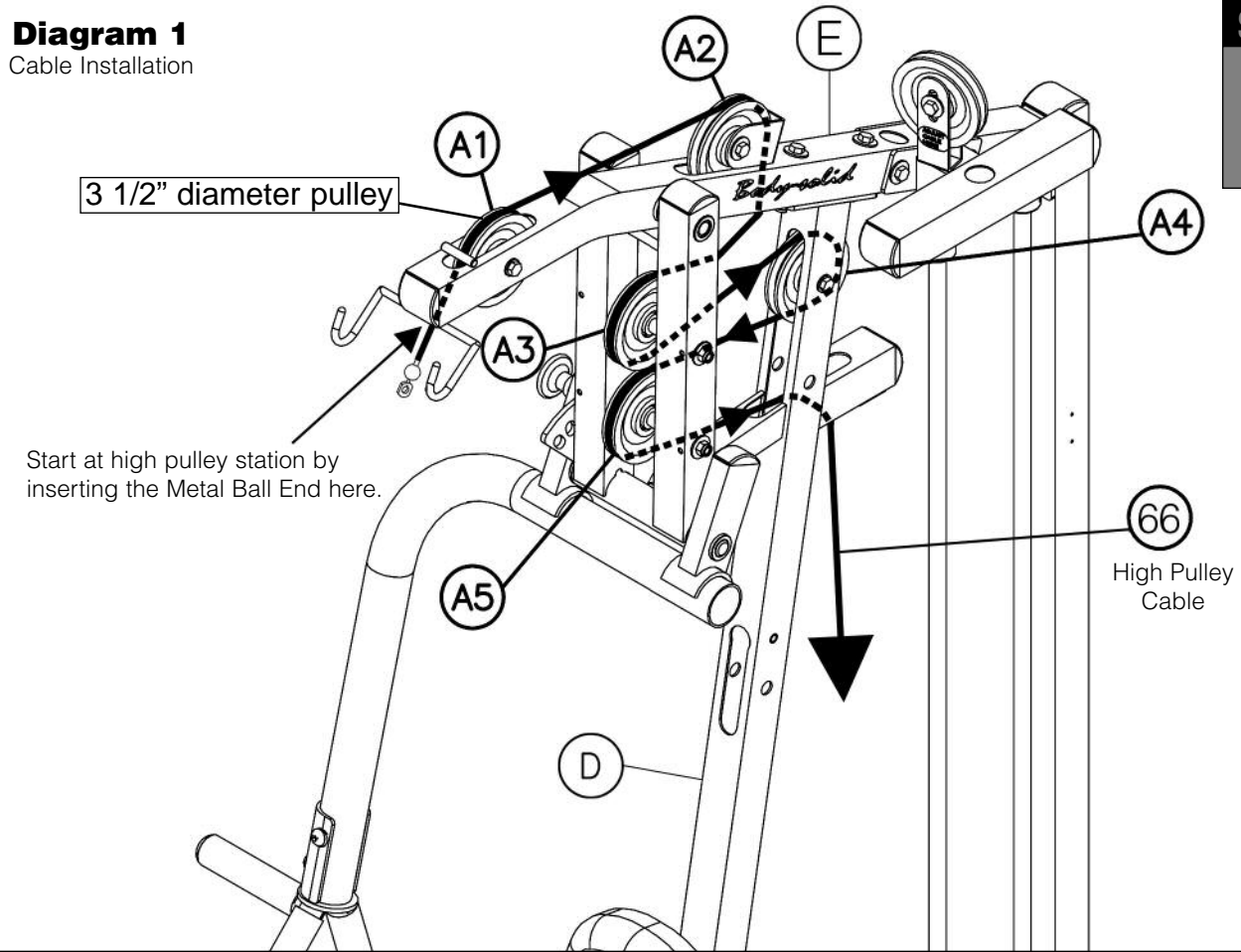
**All Pulleys in this step are 4 1/4" diameter, except where noted in step 8B. Leave all pulley bolts hand tight until step 13 is completed.**

- A. See diagram 1. Begin at the high pulley station. Route the metal ball end of the High Pulley Cable (66) up and through the opening where Pulley (A1) will be installed and then down through the next opening where Pulley (A2) will be installed.
- B. See diagram 2. Install 3 1/2" diameter Pulley (A1) under Cable (66) and into Top Frame (E) as shown using:  
**One 43 (3/8" x 2 3/4" hex head bolt)**  
**Two 15 (pulley spacer)**  
**One 51 (3/8" nylon lock nut)**
- C. See diagram 2. Install Pulley (A2) under Cable (66) and into Top Frame (E) as shown using:  
**One 44 (3/8" x 1 3/4" hex head bolt)**  
**Two 55 (3/8" washer)**  
**One 51 (3/8" nylon lock nut)**
- D. See diagram 1. Route Cable (66) over the top and around pre-installed Pulley (A3) as shown. Route Cable (66) over the top and around Pulley (A4) and install Pulley (A4) into Angled Vertical Frame (D) as shown in diagram 2 using:  
**One 43 (3/8" x 2 3/4" hex head bolt)**  
**Two 15 (pulley spacer)**  
**One 51 (3/8" nylon lock nut)**
- E. See diagram 1. Route Cable (66) between Pulley (A3) and pre-installed Pulley (A5). Route Cable (66) over the top and around Pulley (A5) and back through Angled Vertical Frame (D). Route Cable (66) down through the small arm sticking out of the Angled Vertical Frame (D). And pull entire length of Cable through.
- F. See Diagram 3. Attach Seated Press Shroud (Z) to Seated Press Arm Support (P) using:  
**Four 73 (1/8" x 3/8" screw)**



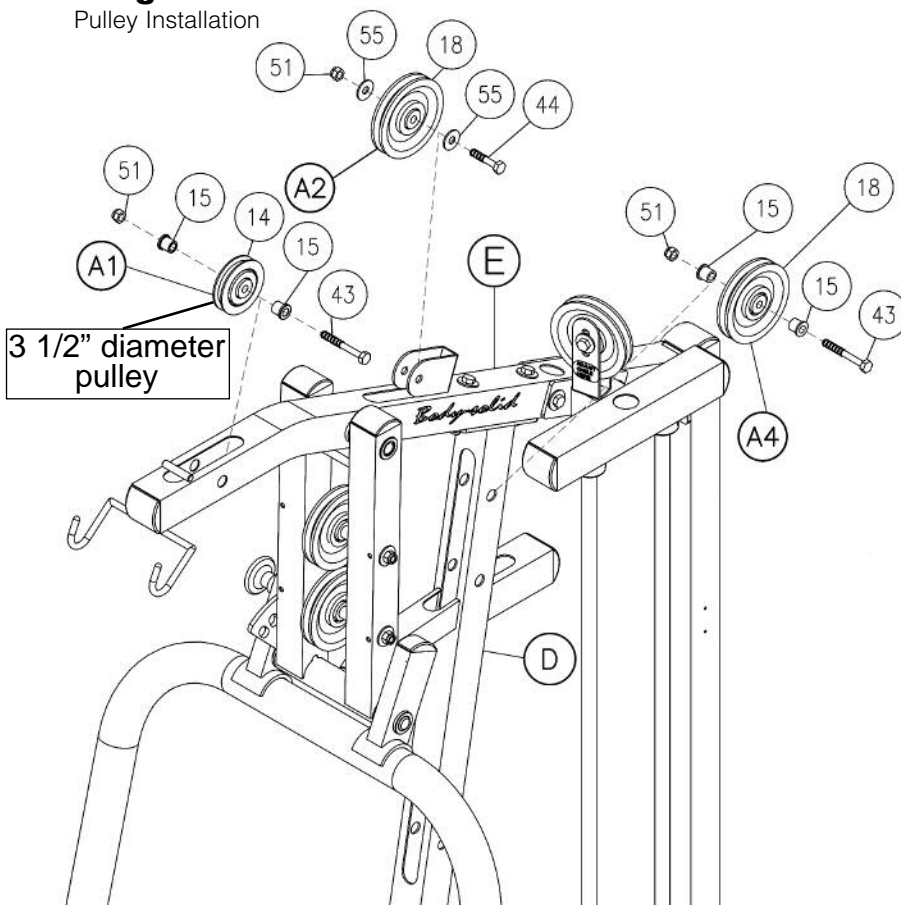
**Diagram 1**

Cable Installation



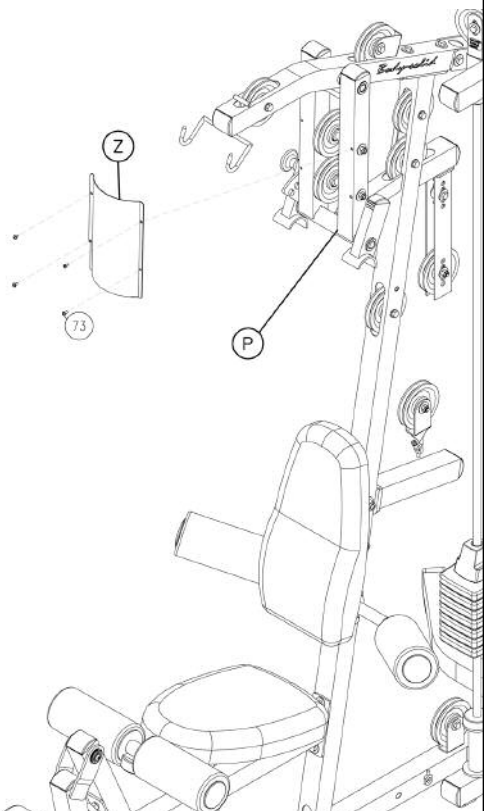
**Diagram 2**

Pulley Installation



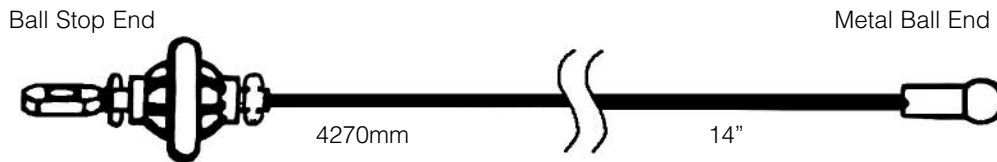
**Diagram 3**

Shroud Installation



**Be careful to assemble all components in the sequence they are presented.**

### **High Pulley Cable (66)**



**Note:**

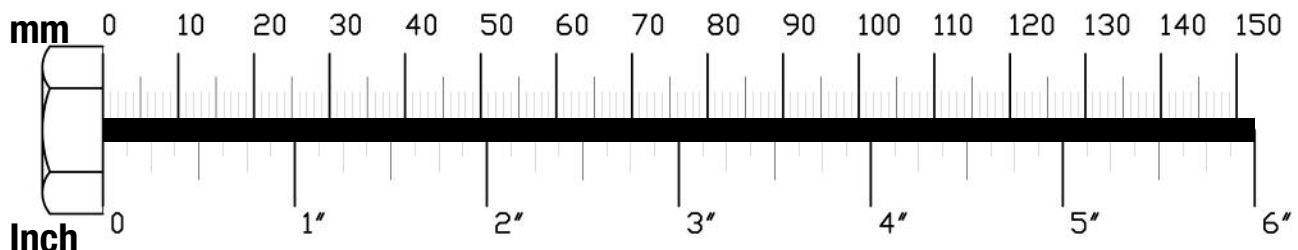
**All Pulleys in this step are 4 1/4" diameter.**

**Leave all pulley bolts hand tight until step 13 is completed.**

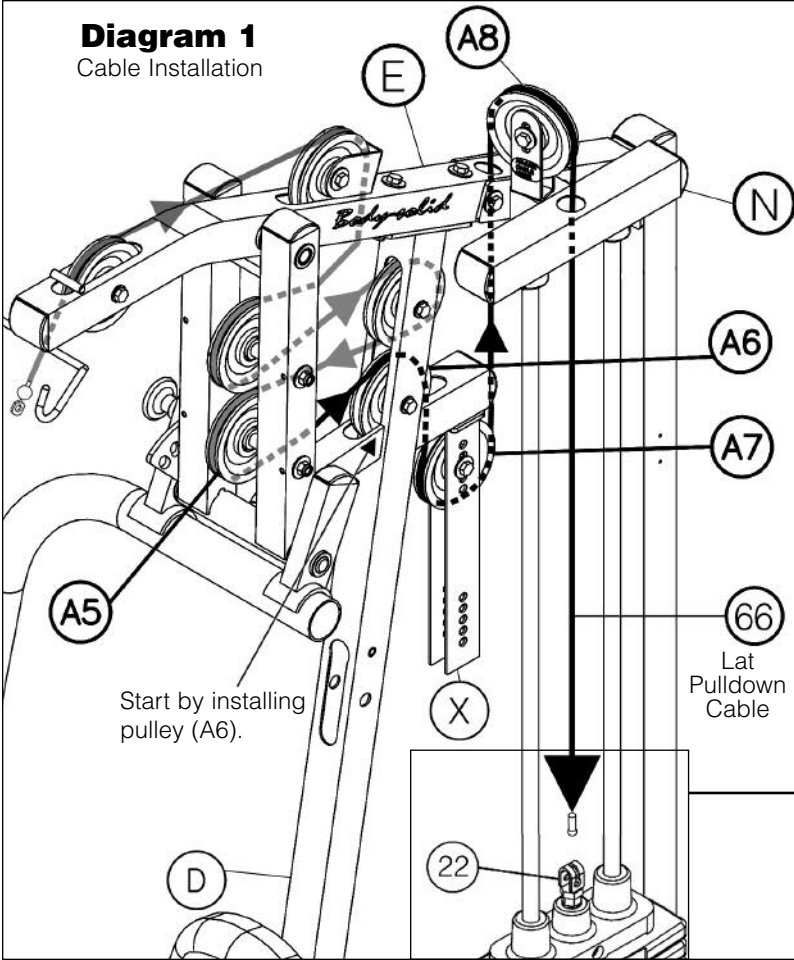
- A. See Diagram 2. Install Pulley (A6) under Cable (66) and into Angled Vertical Frame (D) using:  
**One 43 (3/8" x 2 3/4" hex head bolt)**  
**Two 15 (pulley spacer)**  
**One 51 (3/8" nylon lock nut)**  
 Cable (66) should be hanging down through the small arm sticking out of the Angled Vertical Frame (D).
- B. See Diagram 1. Route Cable (66) through the top of the Double Pulley Holder (X). Install Pulley (A7) using:  
**One 44 (3/8" x 1 3/4" hex head bolt)**  
**One 51 (3/8" nylon lock nut)**
- C. See Diagram 1. Route Cable (66) up through the hole in Top Frame (E), over pre-installed Pulley (A8), and down through Top Weight Stack Frame (N) and toward weight stack.
- D. See Diagram 1A. The Metal Ball End of Cable (66) should be hanging just above the weight stack. Remove Bolt (23) from Selector Rod Top Bolt (22), slide Metal Ball End of Cable (66) through Selector Rod Top Bolt (22). Attach Cable End Shaft (38) and securely tighten Allen Screw (39). Pull Cable (66) tight, so Cable End Shaft (38) fits securely inside Selector Rod Top Bolt (22). Reinstall Bolt (23) in Selector Rod Top Bolt (22).

**NOTE:**

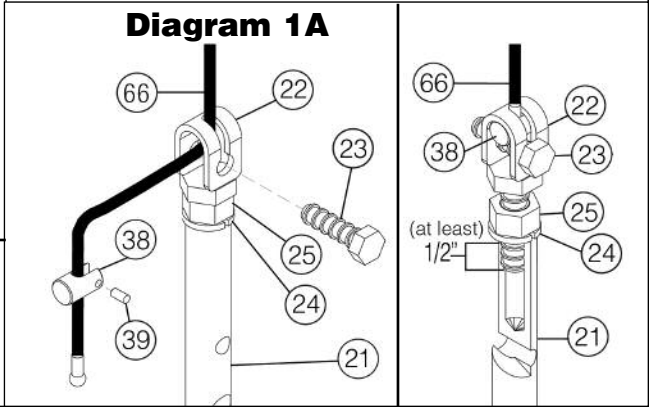
**Make sure the Selector Rod Top Bolt (22) is threaded inside Selector Rod (21) at least one half inch. Make sure Spring Lock Washer (24) is in place and wrench tighten Jam Nut (25).**



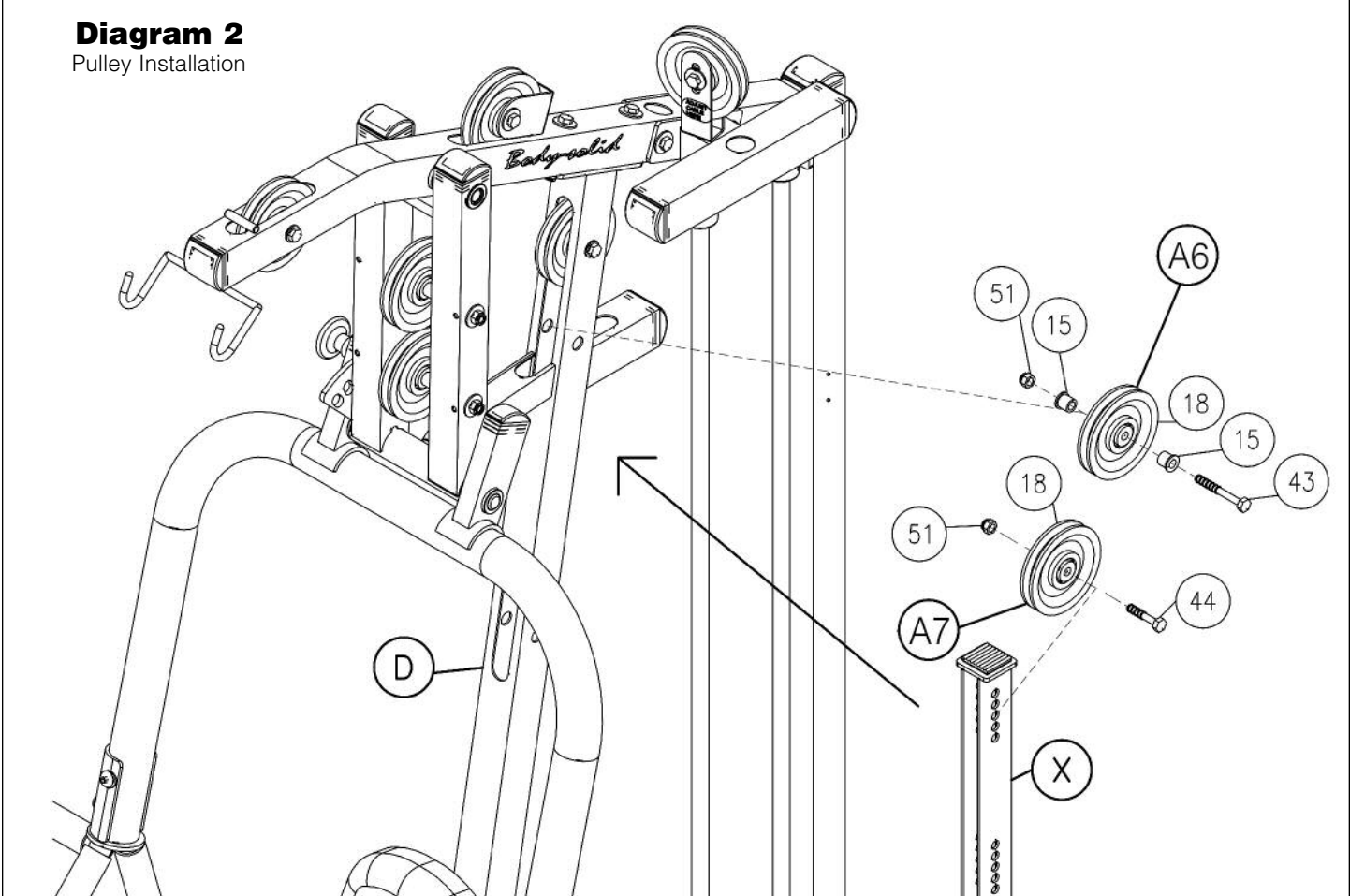
**Diagram 1**  
Cable Installation



**⚠ WARNING ⚠**  
Selector Rod Top Bolt (22) must be threaded a minimum of 1/2" into the Selector Rod (21), and Jam Nut (25) tightened securely against spring lock washer (24) to ensure proper connection. Check the Jam Nut (25) once a week to make sure it is tight.



**Diagram 2**  
Pulley Installation



**Be careful to assemble all components in the sequence they are presented.**

### **Low Pulley Cable (67)**

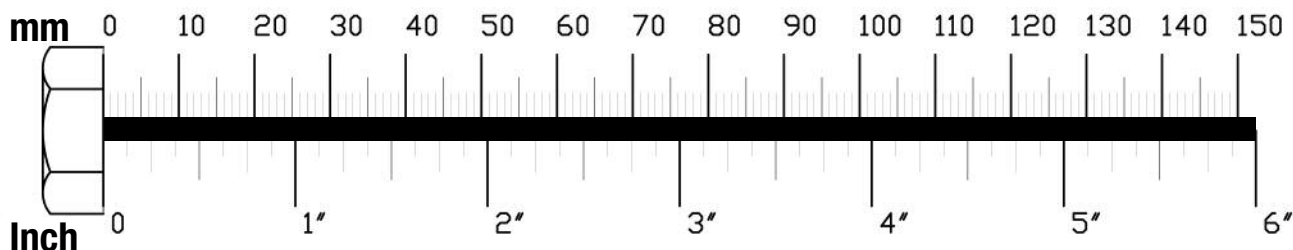


**Note:**

**All Pulleys in this step are 4 1/4" diameter, except where noted in step 10B.**

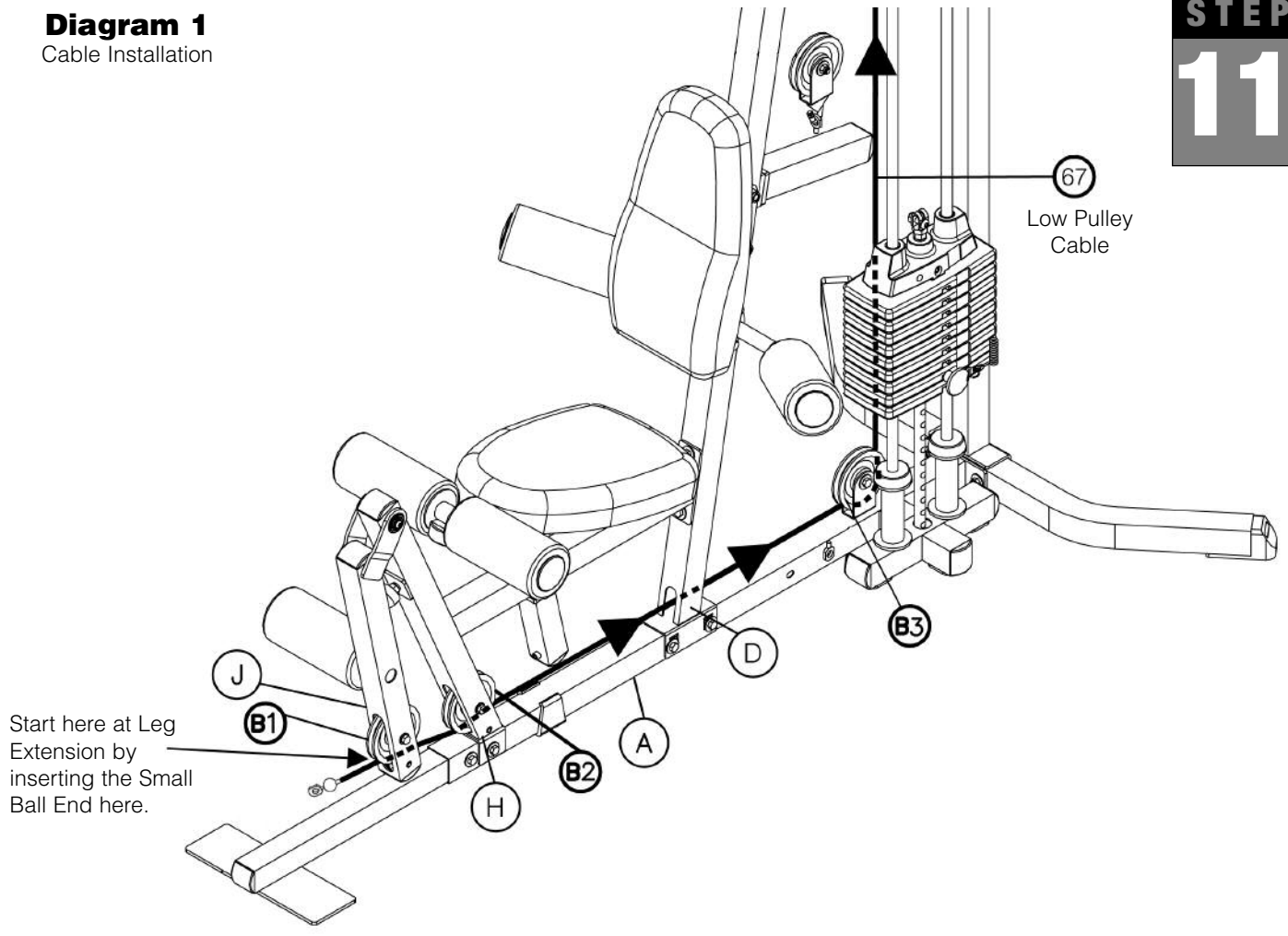
**Leave all pulley bolts hand tight until step 13 is completed.**

- A. See Diagram 1. Insert small ball end of Low Pulley Cable (67) into the opening in Leg Extension (J), where pulley (B1) will be installed. Insert Cable (67) into and through Seat Frame (H). Insert Cable (67) into and through Angled Vertical Frame (D) and pull entire length of Cable (67) through.
- B. See Diagram 2. Install 3 1/2" diameter Pulley (B1), over Cable (67) and into Leg Extension (J) as shown using:  
**One 43 (3/8" x 2 3/4" hex head bolt)**  
**Two 15 (pulley spacer)**  
**One 51 (3/8" nylon lock nut)**
- C. See Diagram 2. Install Pulley (B2), over Cable (67) and into Seat Frame (H) as shown using:  
**One 43 (3/8" x 2 3/4" hex head bolt)**  
**Two 15 (pulley spacer)**  
**One 51 (3/8" nylon lock nut)**
- D. See Diagram 1. Route Cable (67) through the pulley holder mounted on Main Base Frame (A).
- E. See Diagram 2. Install Pulley (B3), over Cable (67) and into the pulley holder mounted on Main Base Frame (A) using:  
**One 44 (3/8" x 1 3/4" hex head bolt)**  
**Two 55 (3/8" washer)**  
**One 51 (3/8" nylon lock nut)**



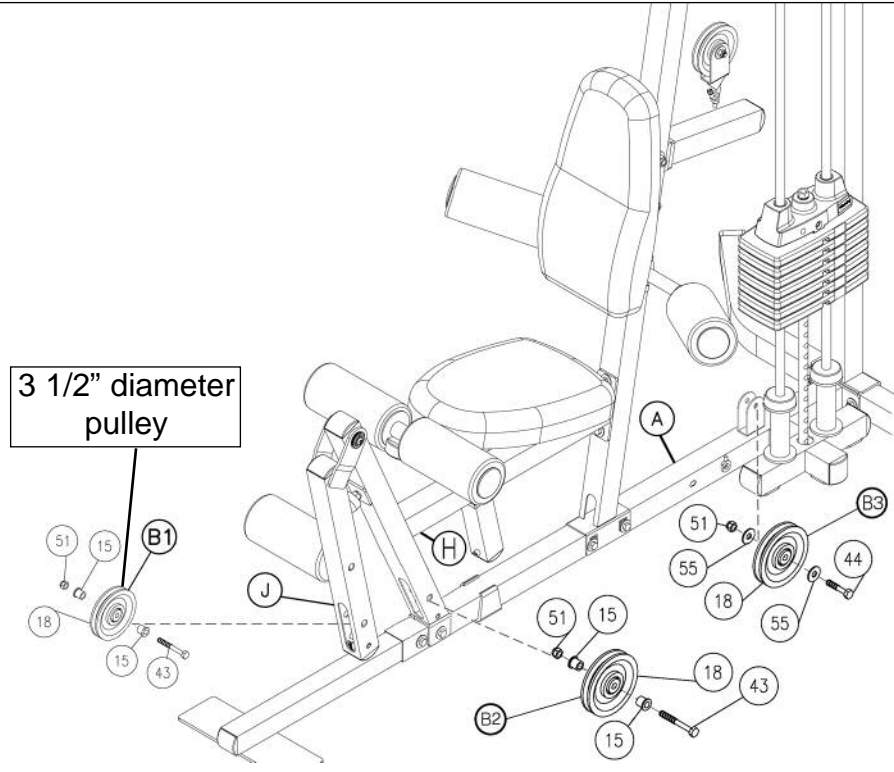
**Diagram 1**

Cable Installation



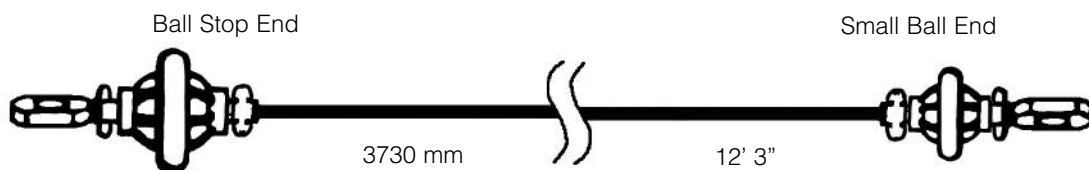
**Diagram 2**

Pulley Installation



**Be careful to assemble all components in the sequence they are presented.**

### **Low Pulley Cable (67)**



### **Short Cable (68)**

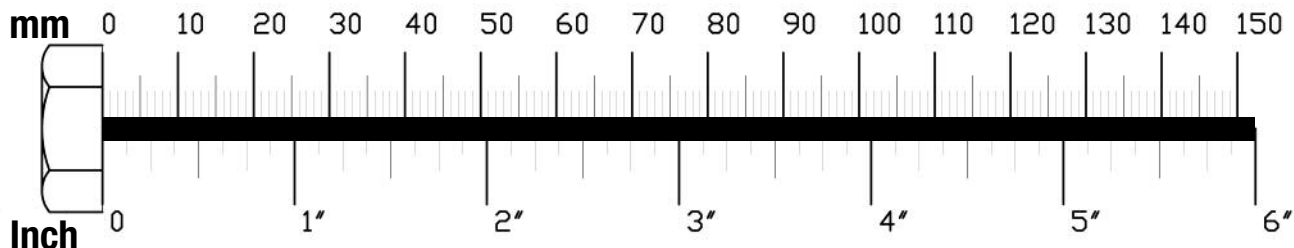


**Note:**

**All Pulleys in this step are 4 1/4" diameter.**

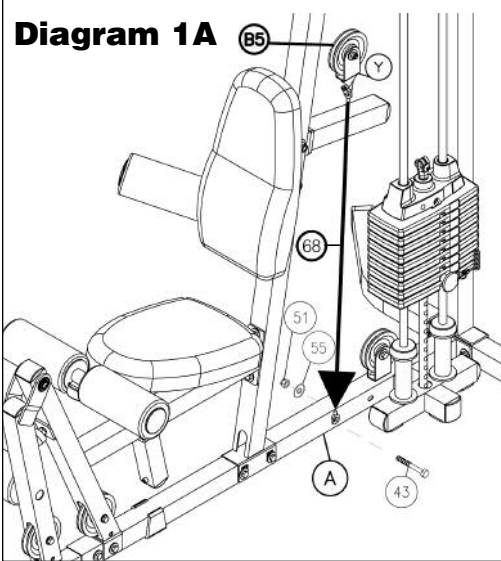
**Leave all pulley bolts hand tight until step 13 is completed.**

- A. See Diagram 1. Route Cable (67) up and through Double Pulley Holder (X). Route Cable (67) around Pulley (B4) and install Pulley (B4) using:  
**One 44 (3/8" x 1 1/2" hex head bolt)**  
**One 51 (3/8" nylon lock nut)**
- B. See Diagram 1. Route Cable (67) through Pulley Holder (Y). Route Cable (67) around Pulley (B5) and install Pulley (B5) using:  
**One 44 (3/8" x 1 1/2" hex head bolt)**  
**One 51 (3/8" nylon lock nut)**
- C. Insert Cable (67) through Angled Vertical Frame (D) and install Pulley (B6) under Cable (67) as shown using:  
**One 43 (3/8" x 2 3/4" hex head bolt)**  
**Two 15 (nylon bushing)**  
**One 51 (3/8" nylon lock nut)**
- D. See Diagram 1A. Attach Short Cable (68) to Main Base Frame (A) using:  
**One 43 (3/8" x 2 3/4" hex head bolt)**  
**One 55 (3/8" washer)**  
**One 51 (3/8" nylon lock nut)**
- F. See Diagram 1A. Attach the other end of Cable (68) to the hook on the bottom of Pulley Holder (Y).



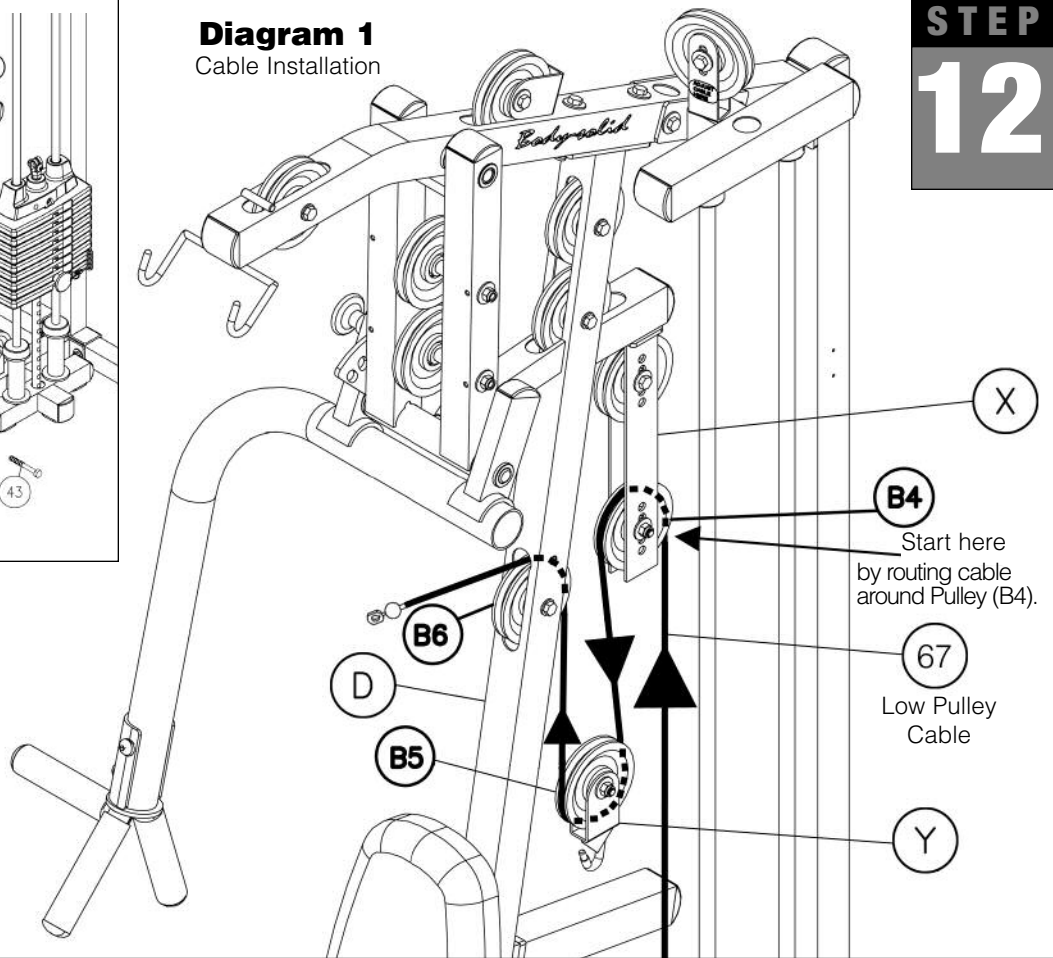


**Diagram 1A**

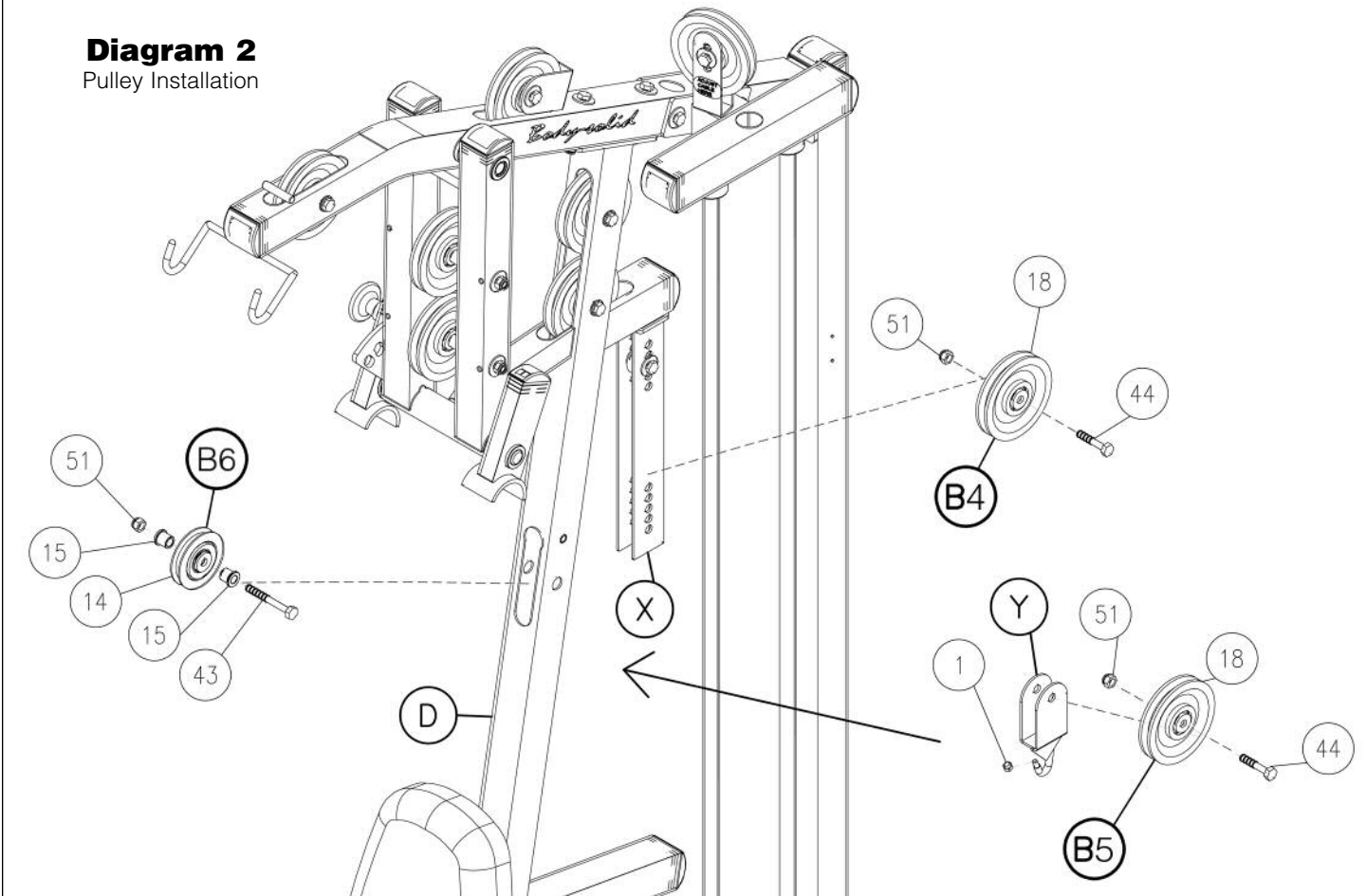


**Diagram 1**  
Cable Installation

**STEP**  
**12**



**Diagram 2**  
Pulley Installation



**Be careful to assemble all components in the sequence they are presented.**

**NOW IS THE TIME TO MAKE ALL NECESSARY CABLE ADJUSTMENTS**

After cable installation is complete you must check all cables for proper tension. Obvious signs that cable tension problems exist include:

- Top Plate (20) does not rest directly on the top Weight Stack Plate (26).
- The holes in the Selector Rod (21) do not line up with holes in the Weight Stack Plates (26).
- Cable(s) are sloppy and there is no resistance from the weight stack for the first few inches of the exercise.

There are Five areas for cable adjustment on the G3S:

- A. Selector Rod Top Bolt (22)
- B. Two adjustments in Double Pulley Holder (X).
- C. Two Rubber Stops (85) one on Angled Vertical Frame (D) and one on Seat Frame (H).

**SEE NOTE 1 ON PAGE 27**

If there is too much tension, and the Top Plate (20) is not resting directly on top of the weight stack plates:

- 1st. -Tighten Rubber Stop (85).
- 2nd. -Move Pulley (B4) down to a lower hole in Double Pulley Holder (X), or move Pulley (A7) up to a higher hole in Double Pulley Holder (X).

If there is too much play or excessive slack;

- 1st. -Loosen Rubber Stop (85).
- 2nd. -Move Pulley (B4) up to a higher hole in Double Pulley Holder (X), or move Pulley (A7) down to a lower hole in Double Pulley Holder (X).
- 3rd. -Screw the Selector Rod Top Bolt (22) farther into the Selector Rod (21) of the weight stack.

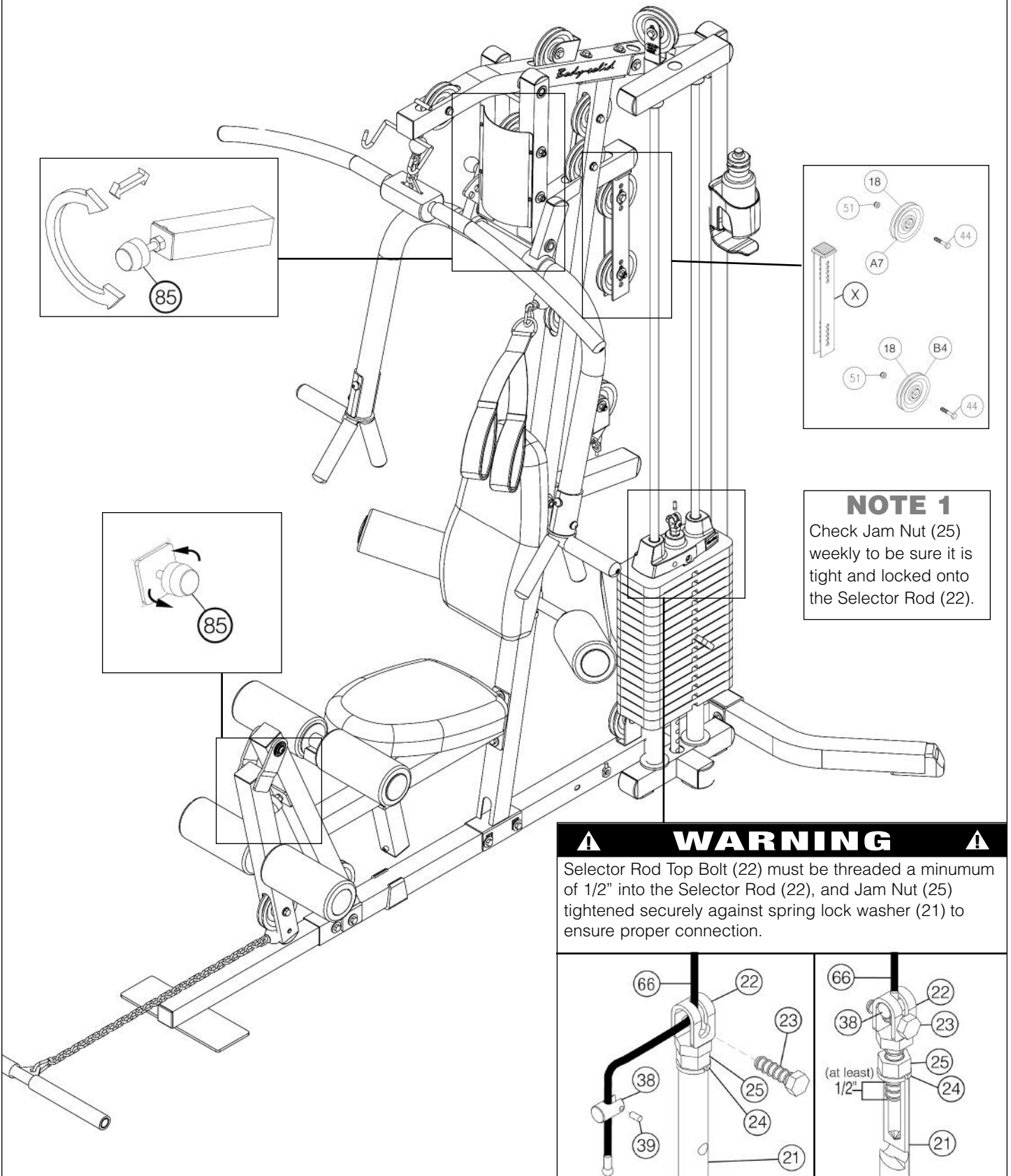
**NOTE:**

**Cables should be inspected daily and adjusted periodically to ensure safe and smooth operation.**

**NOTE:**

**After cable adjustment is complete, you should now wrench tighten all bolts. Do NOT re-tighten any pad bolts.**

# STEP 13

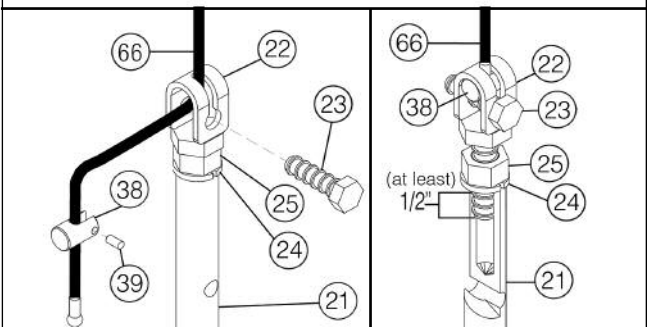


### NOTE 1

Check Jam Nut (25) weekly to be sure it is tight and locked onto the Selector Rod (22).

## ⚠ WARNING ⚠

Selector Rod Top Bolt (22) must be threaded a minimum of 1/2" into the Selector Rod (22), and Jam Nut (25) tightened securely against spring lock washer (21) to ensure proper connection.



## G 3 S Mainframe Parts List

<b>KEY#</b>	<b>QTY</b>	<b>PART#</b>	<b>DESCRIPTION</b>
A	1	G3SMBF-A	MAIN BASE FRAME
B	1	G3SRBF-B	REAR BASE FRAME
C	1	G3SRVF-C	REAR VERTICAL FRAME
D	1	G3SAVF-D	ANGLED VERTICAL FRAME
E	1	G3STF-E	TOP FRAME
F	1	G3SFF-F	FRONT FRAME
G	1	G3SBPA-G	BACK PAD ADJUSTER
H	1	G3SSF-H	SEAT FRAME
J	1	G3SLE-J	LEG EXTENSION
K	2	G3SFRB-K	FOAM ROLLER BAR
L	1	G3SLSPH-L	LEFT SEATED PRESS HANDLE
M	2	G3SCGR-M	CHROME GUIDE ROD
N	1	G3STWSF-N	TOP WEIGHT STACK FRAME
P	1	G3SSPAS-P	SEATED PRESS ARM SUPPORT
Q	1	G3SSPA-Q	SEATED PRESS ARM
R	1	G3SRSPH-R	RIGHT SEATED PRESS HANDLE
S	1	G3SBPF-S	BACK PAD FRAME
T	1	G3SABPF-T	ADJUSTABLE BACK PAD FRAME
V	1	G3SSPF-V	SEAT PAD FRAME
X	1	G3SDPH-X	DOUBLE PULLEY HOLDER
Y	1	G3SPH-Y	PULLEY HOLDER
Z	1	G3SSPS-Z	SEATED PRESS SHROUD
AA	1	G3SLLHD-AA	LEFT LEG HOLD DOWN
AB	1	G3SRLHD-AB	RIGHT LEG HOLD DOWN

**Part numbers are required when ordering parts.**

# G 3 S Hardware List

KEY#	QTY	PART#	DESCRIPTION
1	1	JACN.19	ACORN CAP NUT 3/16" ID -PREINSTALLED
2	4	JFEC1.75	FLAT END CAP 1 3/4" x 1 3/4"
3	2	JPW3	PLASTIC WASHER 3"
4	5	JCEC1.8	2" X 2" X 1.8" CONVEX END CAP
5	6	JCEC12	1" X 2" CONVEX END CAP
6	2	JFC22	FOOT CAP 2" X 2"
7	2	JNB22	NYLON BUSHING 2" X 2"
8	1	JFL22	FRAME LEVELER 2" X 2"
9	6	JFREC2.5	FOAM ROLLER END CAP 2.5" OD X 1" ID
10	1	JRP2450	RUBBER PAD 1 1/2" X 1 1/2"
11	2	JRD2.5	RUBBER DONUT 2 1/2"
12	3	JWSS22	WEIGHT STACK SHIM 2" X 2"
13	2	JSC1.37X.75	SHAFT COLLAR 1 3/8" OD 3/4 ID 1.5" L
14	3	JPP3.5W.75	PLASTIC PULLEY 3 1/2" X 3/4"
15	12	JPB.56X.37	PULLEY SPACER 9/16" OD X 3/8" ID X 5/8" L (15mm X 9mm X 17mm)
16	4	JSNAP3	SNAP LINK 3 1/4"
17	4	JSB.5	SPACER SLEEVE 1/2" OD X 7/16" ID X 7/8" L
18	11	JPP4.25W.75	PLASTIC PULLEY 4 1/4" X 3/4"
19	6	JFOAM48	FOAM ROLLER 4" X 8"
20	1	JTP10	TOP PLATE (10 lbs.)
21	1	JSR20	SELECTOR ROD (20 selector holes)
22	1	JSRTB.5	SELECTOR ROD TOP BOLT 1/2" X 2" FULL THREAD
23	1	JHEX.37X.87FTB	HEX HEAD BOLT 3/8" X 7/8" FULL THREAD
24	1	JWSW.5	SPRING LOCK WASHER 1/2"
25	1	JJN.5	JAM NUT 1/2"
26	15	JSP10	WEIGHT PLATE 10lbs
27	2	JWSR4.87	WEIGHT STACK RISER 4 7/8"L
28	6	JREC1.25	ROUND END CAP 1"
29	1	JSH3X.5	SHAFT 3" X 1/2"
30	2	JRAB.25X.56FTB	ROUND ALLEN BOLT 1/4" X 9/16" FULL THREAD
31	2	JWSW.25X.62	WASHER 1/4" ID X 5/8" OD
32	2	JRR1.37X1.125	RETAINING RING 1 3/8" OD X 1 1/8" ID
33	2	JB1.25X.5	BUSHING 1 1/4" OD X 1/2" ID
35	1	JWB	WATER BOTTLE
36	1	JWBH	WATER BOTTLE HOLDER
37	1	JWBB	WATER BOTTLE BRACKET
38	1	JAS.125X.25	ALLEN SCREW 1/8" X 1/4"
39	1	JCES.75	CABLE END SHAFT 3/4" L

**Continued on next page**



**Part numbers are required when ordering parts.**

## G 3 S Hardware (continued)

KEY#	QTY	PART#	DESCRIPTION
40	2	JHEX.5X3PTB	HEX HEAD BOLT 1/2" X 3" PARTIAL THREAD
41	2	JHEX.37X7PTB	HEX HEAD BOLT 3/8" X 7" PARTIAL THREAD
42	8	JHEX.37X3PTB	HEX HEAD BOLT 3/8" X 3" PARTIAL THREAD
43	12	JHEX.37X2.75PTB	HEX HEAD BOLT 3/8" X 2 3/4" PARTIAL THREAD
44	6	JHEX.37X1.5PTB	HEX HEAD BOLT 3/8" X 1 1/2" PARTIAL THREAD
45	4	JHEX.31X1.75PTB	HEX HEAD BOLT 5/16" X 1 3/4" PARTIAL THREAD
46	1	JSHB.37X1.5FTB	SOCKET HEAD BOLT 3/8" X 1 1/2" FULL THREAD
47	1	JWSW.43	SPRING LOCK WASHER 7/16"
50	2	JNLN.5	NYLON LOCK NUT 1/2"
51	31	JNLN.37	NYLON LOCK NUT 3/8"
54	2	JWFLT.5	WASHER 1/2"
55	14	JWFLT.37	WASHER 3/8"
56	6	JWC.37	CURVED WASHER 3/8"
57	5	JWFLT.37X.75	WASHER 3/8" X 3/4" O.D.
58	4	JWFLT.31	WASHER 5/16"
59	4	JWSW.31	SPRING LOCK WASHER 5/16"
60	1	JPIN4.25	WEIGHT STACK PIN 5 1/2"L
61	1	JSCH.18	STEEL CHAIN 3/16"
62	3	JHEX.37X2.5PTB	HEX HEAD BOLT 3/8" X 2 1/2" PARTIAL THREAD
63	2	JCB.37X2.75PTB	CARRIAGE BOLT 3/8" X 2 3/4" PARTIAL THREAD
64	2	JTNB2X2	THICK NYLON BUSHING 2" X 2"
65	1	JFP2X4	FLAT PLATE 2" X 4"
70	3	JFP2X5.5	FLAT PLATE 2" X 5 1/2"
71	1	JSH.75X6.5	SHAFT 3/4" X 6 1/2"
72	1	JSH.75X9.5	SHAFT 3/4" X 9 1/2"
73	6	JS.125X.37	SCREW 1/8" X 3/8" FULL THREAD
74	2	JOB1.37X.75	OILITE BUSHING 1 3/8" OD X 3/4" ID 5/8" L -PREINSTALLED
75	2	JPB1.5X.75	PLASTIC BUSHING 1 1/2" OD X 3/4" ID 1" L -PREINSTALLED
76	5	JAS.31X.31	ALLEN SCREW 5/16" X 5/16" FULL THREAD
77	1	JBHPP3.75	FLAT POP PIN 3 3/4"L
78	1	JBHPP6.5	FLAT POP PIN 6 1/2"L
79	2	JTSP3	T-SHAPED POP PIN 3"L
80	7	JRAH.37X.62FTB	ROUND ALLEN HEAD 3/8" X 5/8" FULL THREAD
81	2	JFAH.31X.37FTB	SOCKET HEAD BOLT 5/16" X 3/8" FULL THREAD
82	2	JOB.75X.5	OILITE BUSHING 3/4" OD X 1/2" ID 1/2" L -PREINSTALLED
83	1	JFAH.37X.5FTB	SOCKET HEAD BOLT 3/8" X 1/2" FULL THREAD
84	2	JJN.31	JAM NUT 5/16"
85	2	JRS2.5	RUBBER STOP 2 1/2"L
93	2	JWFLT.125	WASHER 1/8"
94	1	JWSPLY	WEIGHT STACK PIN LANYARD
99	1	JSH.5X3	SHAFT 1/2" X 3"
100	4	REC1.5	ROUND END CAP 1 1/2"

**Part numbers are required when ordering parts.**

## **P a d s L i s t**

<b>KEY#</b>	<b>QTY</b>	<b>PART#</b>	<b>DESCRIPTION</b>
U	1	G3SBP-U	BACK PAD
W	1	G3SSP-W	SEAT PAD

## **C a b l e L i s t**

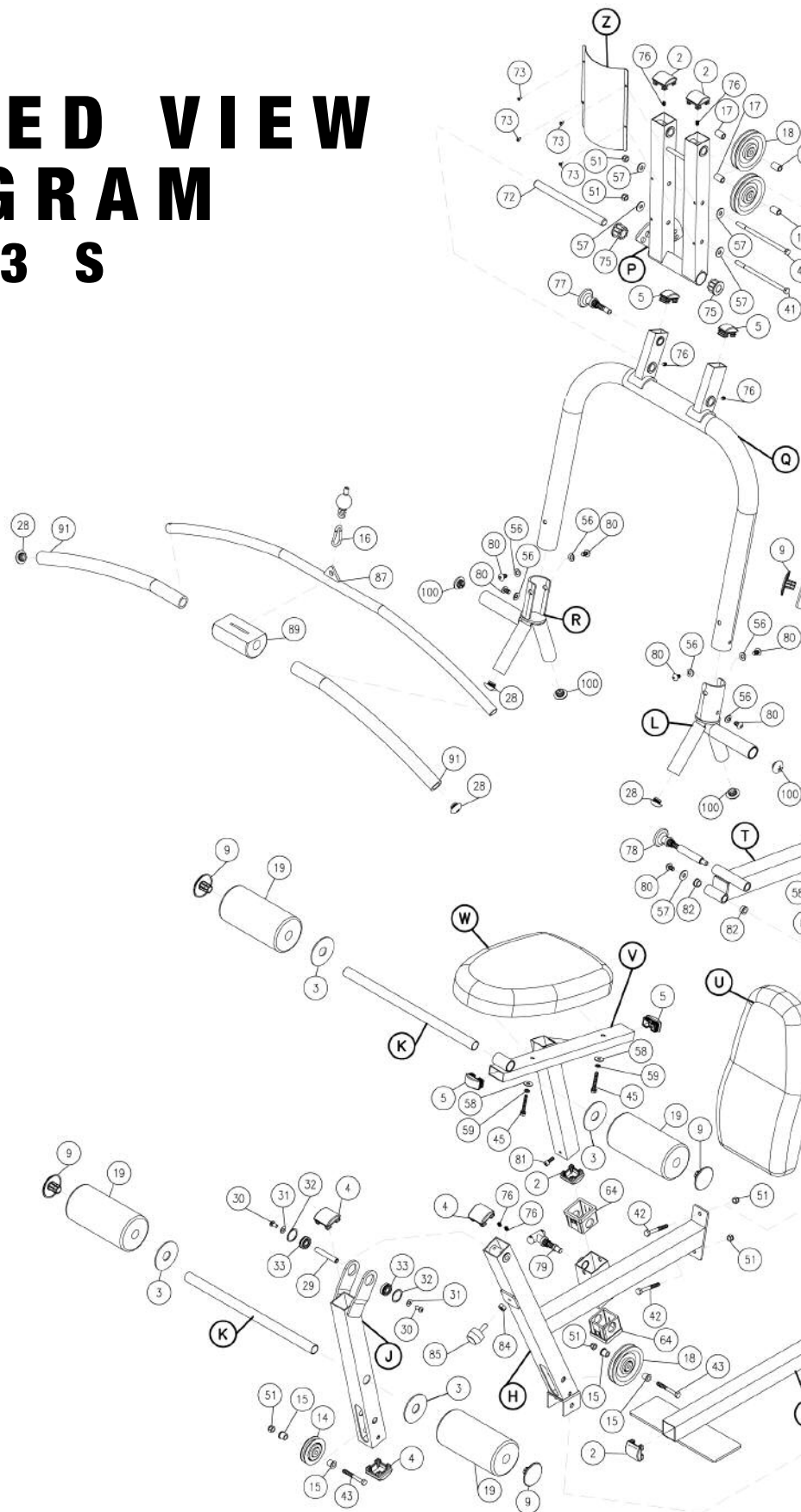
<b>KEY#</b>	<b>QTY</b>	<b>PART#</b>	<b>DESCRIPTION</b>
66	1	JHPC4155	HIGH PULLEY CABLE 4270 mm (14')
67	1	JLPC4030	LOW PULLEY CABLE 3730 mm (12' 3")
68	1	JSC595	SHORT CABLE 757mm (2' 6")

## **A c c e s s o r i e s L i s t**

<b>KEY#</b>	<b>QTY</b>	<b>PART#</b>	<b>DESCRIPTION</b>
86	1	JG3SACH	AB CRUNCH HARNESS
87	1	JG3SLB	LAT BAR
88	1	JG3SLRB	LOW ROW BAR
89	1	JG3SLBP	LAT BAR PAD
90	2	JFG8.5	FOAM GRIP 1 1/2" OD X 8 1/2" L
91	2	JFG20.5	FOAM GRIP 1 1/2" OD X 20 1/2" L
92	6	JFG5.5	FOAM GRIP 1 1/2" OD X 5 1/2" L
95	1	JG3SAS	ANKLE STRAP

**Part numbers are required when ordering parts.**

# EXPLODED VIEW DIAGRAM G 3 S



© Copyright 2003. Body-Solid. All rights reserved. Body-Solid reserves the right to change design and specifications when we feel it will improve the product. Body-Solid machines maintain several patented and patent pending features and designs. All rights reserved on all design patents and utility patents.



