

Body-Solid

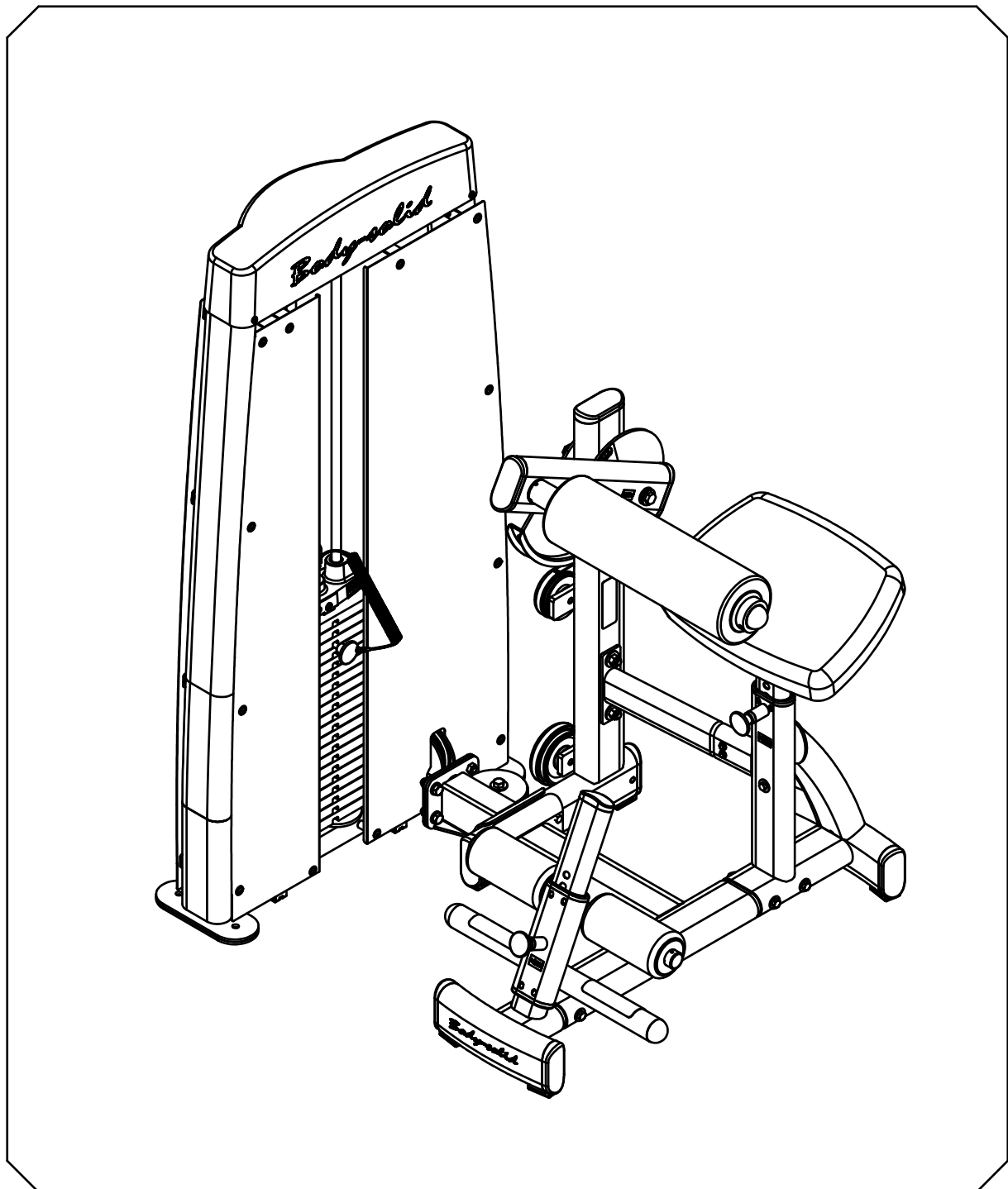

BODY-SOLID, Inc.
1900 S. Des Plaines Ave.
Forest Park, IL 60130 USA
Phone: (708) 427-3555
Fax: (708) 427-3556
www.bodysolid.com

DABB.2 OWNER'S MANUAL

DABB ASSEMBLY INSTRUCTIONS

HARDWARW ILLUSTRATION

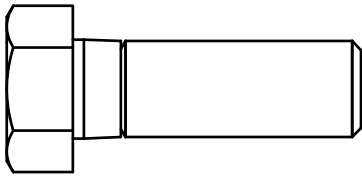

(A1)HEX BOLT 1/2"X1-1/2"L PARTIAL QTY.3

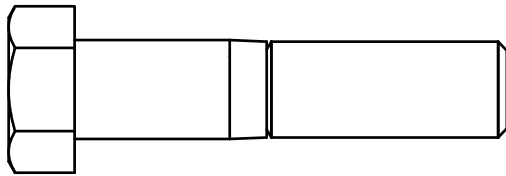

(A2)HEX BOLT 1/2"X2-1/4"L PARTIAL QTY.1

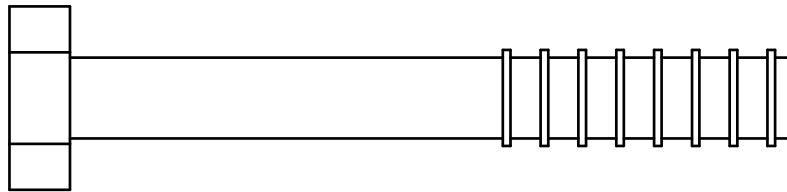

(A3)HEX BOLT 1/2"X3-3/4"L PARTIAL QTY.2

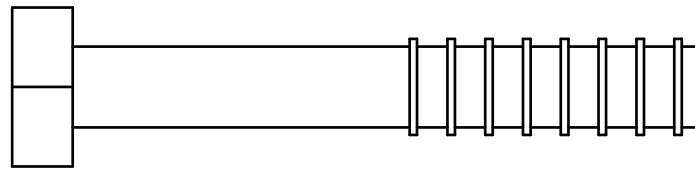

(A4)HEX BOLT 3/8"X3-1/4"L PARTIAL QTY.3

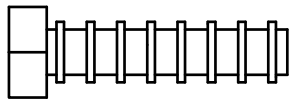

(A5)HEX BOLT 5/16"X1-1/4"L PARTIAL QTY.4

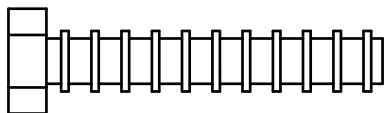

(A6)HEX BOLT 5/16"X1-3/4"L PARTIAL QTY.1

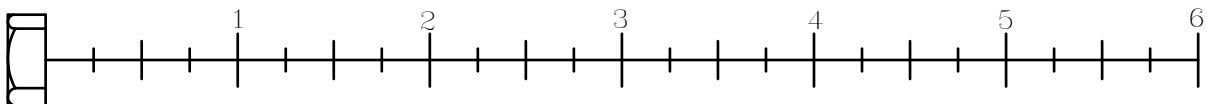

DABB ASSEMBLY INSTRUCTIONS

HARDWARW ILLUSTRATION

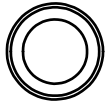

(A7)STEEL BUSHING $\text{Ø}1/2\text{''} \times \text{Ø}8.5 \times 21\text{L}$ QTY.1

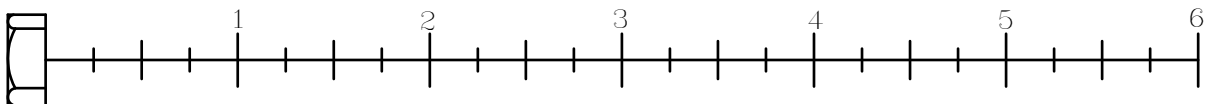

DABB ASSEMBLY INSTRUCTIONS

HARDWARW ILLUSTRATION

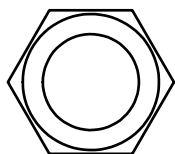
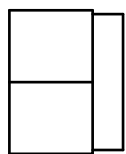

(B1) NYLON LOCK NUT 1/2" QTY.6

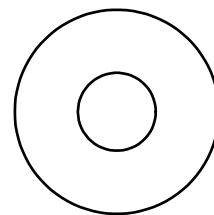

(C3) 3/8" (I.D.) FLAT WASHER Ø27 QTY.6

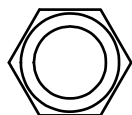
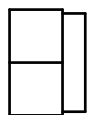

(B2) NYLON LOCK NUT 3/8" QTY.3

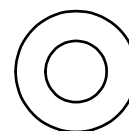

(C4) 5/16" (I.D.) FLAT WASHER Ø16 QTY.2

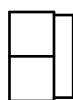

(B3) NYLON LOCK NUT 5/16" QTY.1

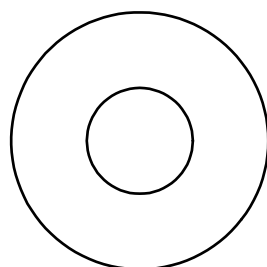
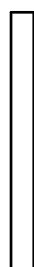

(C1) 1/2" (I.D.) FLAT WASHER Ø34 QTY.6

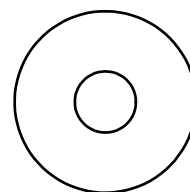

(C5) 5/16" (I.D.) FLAT WASHER Ø24 QTY.4

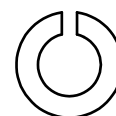

(C6) SPRING WASHER 5/16" QTY.4

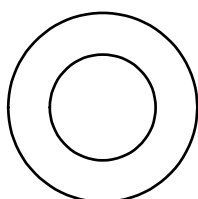

(C2) 1/2" (I.D.) FLAT WASHER Ø25 QTY.6

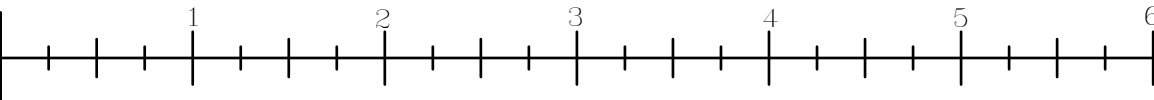

DABB ASSEMBLY INSTRUCTIONS

HARDWARW ILLUSTRATION

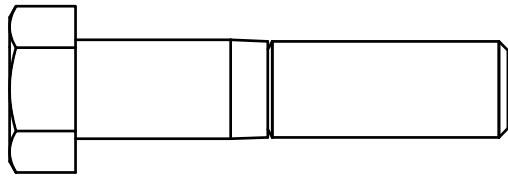

(AA2)HEX BOLT 1/2"X2-1/4"L PARTIAL QTY.3

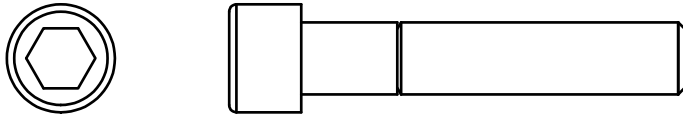

(AA4)ROUND INNER HEAD 3/8"X2"L PARTIAL QTY.1

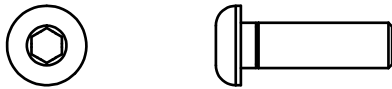

(AA5)ROUND INNER HEX SCREW M6X20L PARTIAL QTY.20



(AA6)ROUND CROSS SCREW 5/32"X1/4"L PARTIAL QTY.4

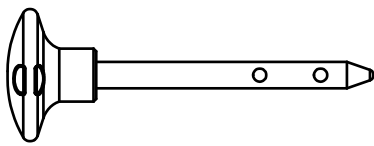

(AA7)10LB PIN(8250-071) QTY.1

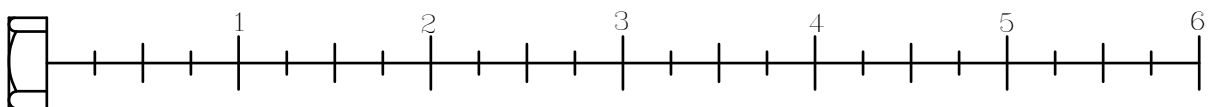

DABB ASSEMBLY INSTRUCTIONS

HARDWARW ILLUSTRATION

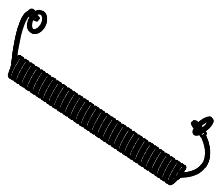

(AA8)ELASTIC BOLT QTY.1

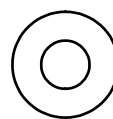

(CC2)M6(I.D.)FLAT WASHER Ø13 QTY.20

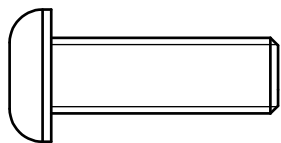
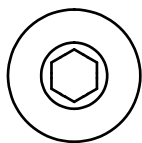

(AA10)ROUND INNER HEX SCREW
M10X30L PARTIAL QTY.1

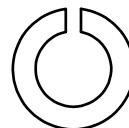

(CC5)SPRING WASHER 3/8" QTY.1

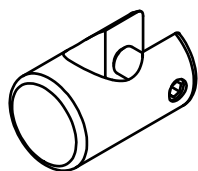

(AA11)FIRM SHEATH(8890-046) QTY.1

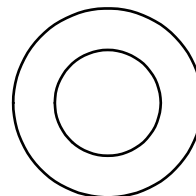
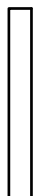

(CC6)1/2"(I.D.)FLAT WASHER Ø25 QTY.2

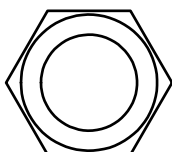
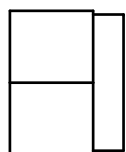

(BB2)NYLON LOCK NUT1/2" QTY.3

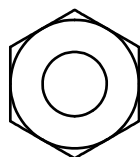
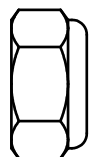

(BB3)NYLON LOCK NUT M10 QTY.1

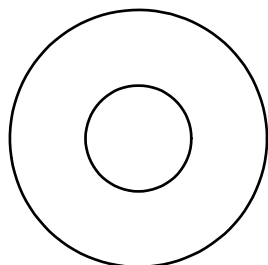

(CC1)1/2"(I.D.)FLAT WASHER Ø34 QTY.4

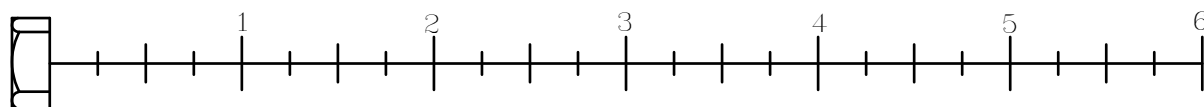

DABB ASSEMBLY INSTRUCTIONS

HARDWARW ILLUSTRATION

		(D1) $\phi 3/4$ " X 13.5 X 8L STEEL BUSHING (8110-014) ----- [2PCS]
		(D2) $\phi 38$ " X $\phi 25.2$ X 27L STEEL BUSHING (8130-159) ----- [1PCS]
		(D3) $\phi 30$ " X $\phi 20$ X 1.5t CU WASHER (8520-007) ----- [1PCS]
		(D4) $\phi 38$ " X $\phi 26$ X 1.5t CU WASHER (8520-008) ----- [1PCS]
		(D5) 95 X 140L RUBBER PAD (9310-035) ----- [2PCS]
		(D6) $\phi 50$ ROUND END CAP (9211-074) ----- [3PCS]
		(D7) 50 X 100 NYLON BUSHING (9211-107) ----- [2PCS]
		(D8) 58 X 116 X 2.5t FOOT CAP (9211-108) ----- [6PCS]
		(D9) 58 X 116 X 2.5t END CAP (9211-112) ----- [3PCS]
		(D10) 40 X 80 X 2t END CAP (9211-113) ----- [1PCS]
		(D11) $\phi 4$ " PULLEY (9213-017A) ----- [2PCS]
		(D12) $\phi 4$ 1/2" PULLEY (9213-010B) ----- [5PCS]
		(D13) $\phi 75$ X 3t X $\phi 26$ NYLON WASHER (9214-008) ----- [4PCS]
		(D14) $\phi 90$ X $\phi 51$ X 3t NYLON WASHER (9214-022) ----- [2PCS]
		(D15) 207 X 105 X 23 PULLEY CAP (9211-115) ----- [1PCS]
		(D16) $\phi 131$ X 30 PULLEY CAP (9211-116) ----- [1PCS]
		(D17) 3425mm STEEL CABLE (FDABBA) ----- [1PCS]
		(D18) $\phi 3/4$ " SHAFT COLLAR (9211-046) ----- [2PCS]
		(D19) $\phi 4$ " RUBBER DOUNT (9310-017) ----- [2PCS]
		(D20) TOP PLATE (8400-006) ----- [1PCS]
		(D22) 95 X 250 RUBBER PAD (9310-060) ----- [2PCS]
		(D23) DABB FOR DGYM STEEL CABLE (FDABBB) ----- [1PCS]
		(D24) WEIGHT SELECTOR BAR (8210-042B) ----- [1PCS]

D1



D2



D3



D4

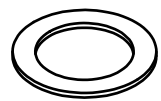

D5



D6



D7

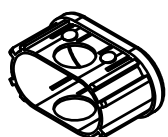

D8



D9

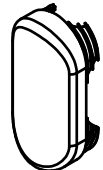

D10



D11



D12

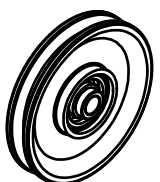

D13



D14



D15

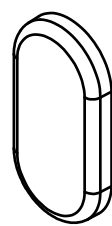

D16



D17

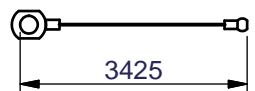

D18



D19



D20

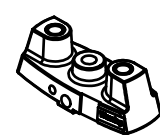

D22



D24

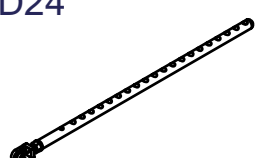

DABB ASSEMBLY INSTRUCTIONS

PARTS ILLUSTRATION

A [1PCS]

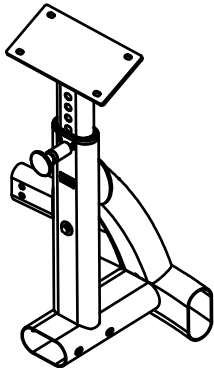

B1 [1PCS]



C [1PCS]

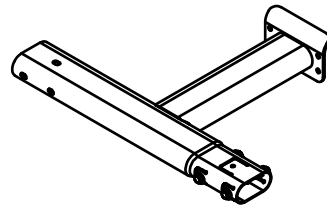

D [1PCS]

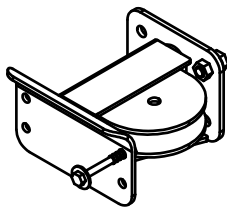

E1 [1PCS]

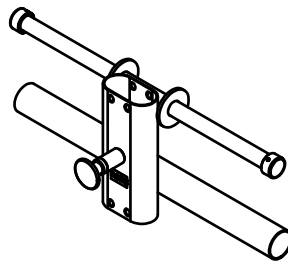

F [1PCS]

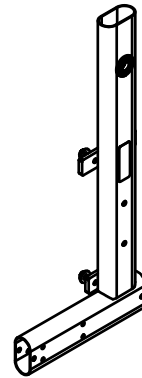

H [1PCS]

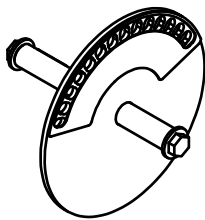

I [1PCS]

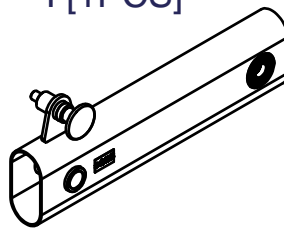

J [1PCS]

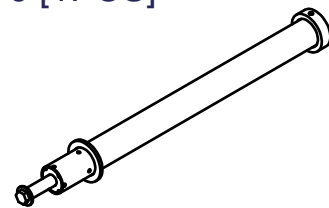

K [1PCS]



L [1PCS]

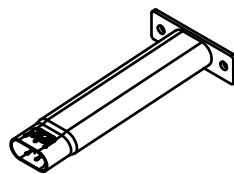

M [1PCS]
8321-091

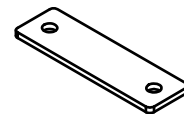

N [1PCS]
9122-039

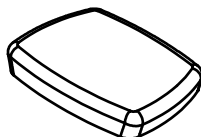

O [1PCS]
9161-047

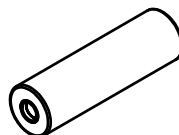

P [2PCS]
9161-032

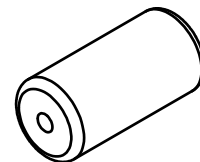

Q [1PCS]
9440-163

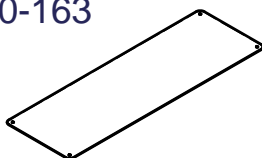

DABB ASSEMBLY INSTRUCTIONS

PARTS ILLUSTRATION

AA[1PCS]
6610-002

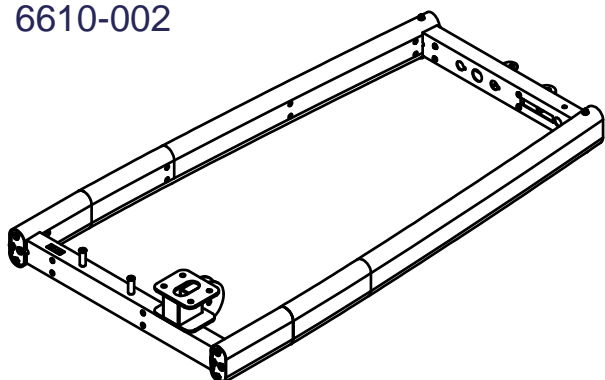

AB[1PCS]
8380-046

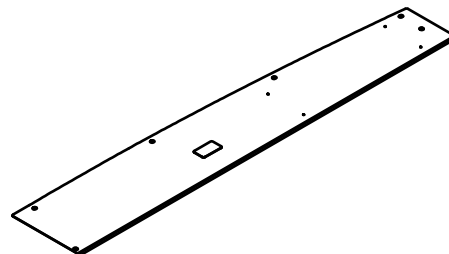

AC[1PCS]
8380-047

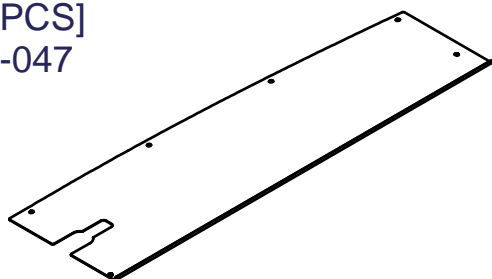

AD[1PCS]
8380-048

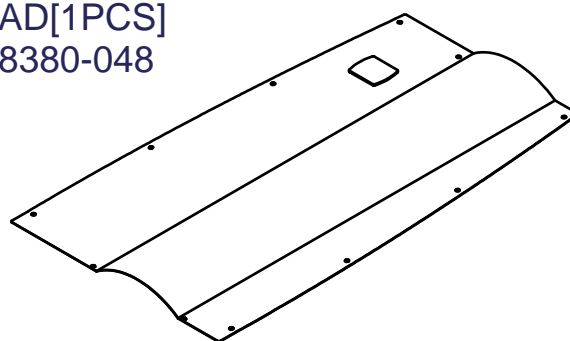

AE[2PCS]
260158A \varnothing 3/4"X1.6tX1407L



AK1PCS]
9211-111A

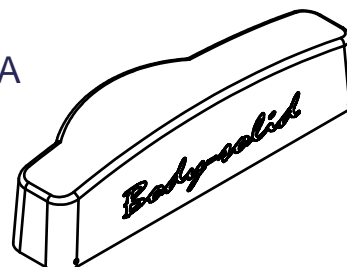

AG[2PCS]
8313-144

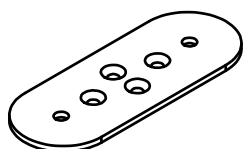

AH[9PCS]
8321-040

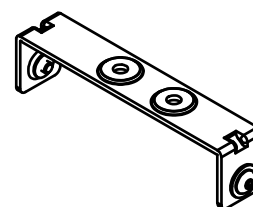
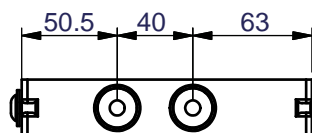

AI[1PCS]
8321-040

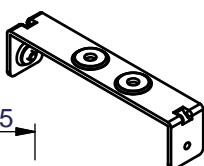
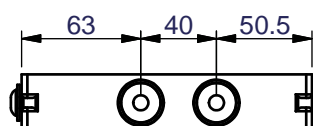

AJ[2PCS]
8321-040

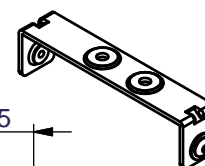
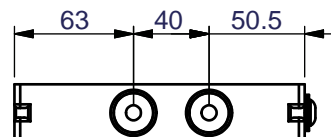

DABB ASSEMBLY INSTRUCTIONS

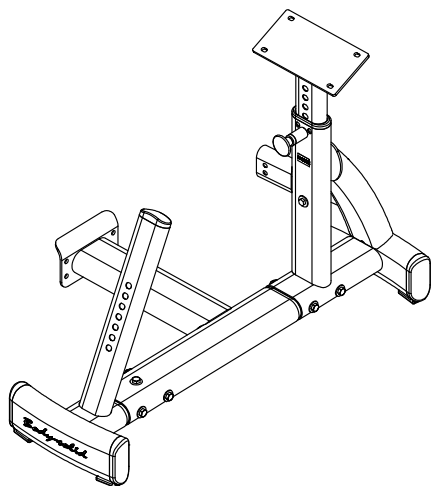

Above shows STEP 1
assembled and completed

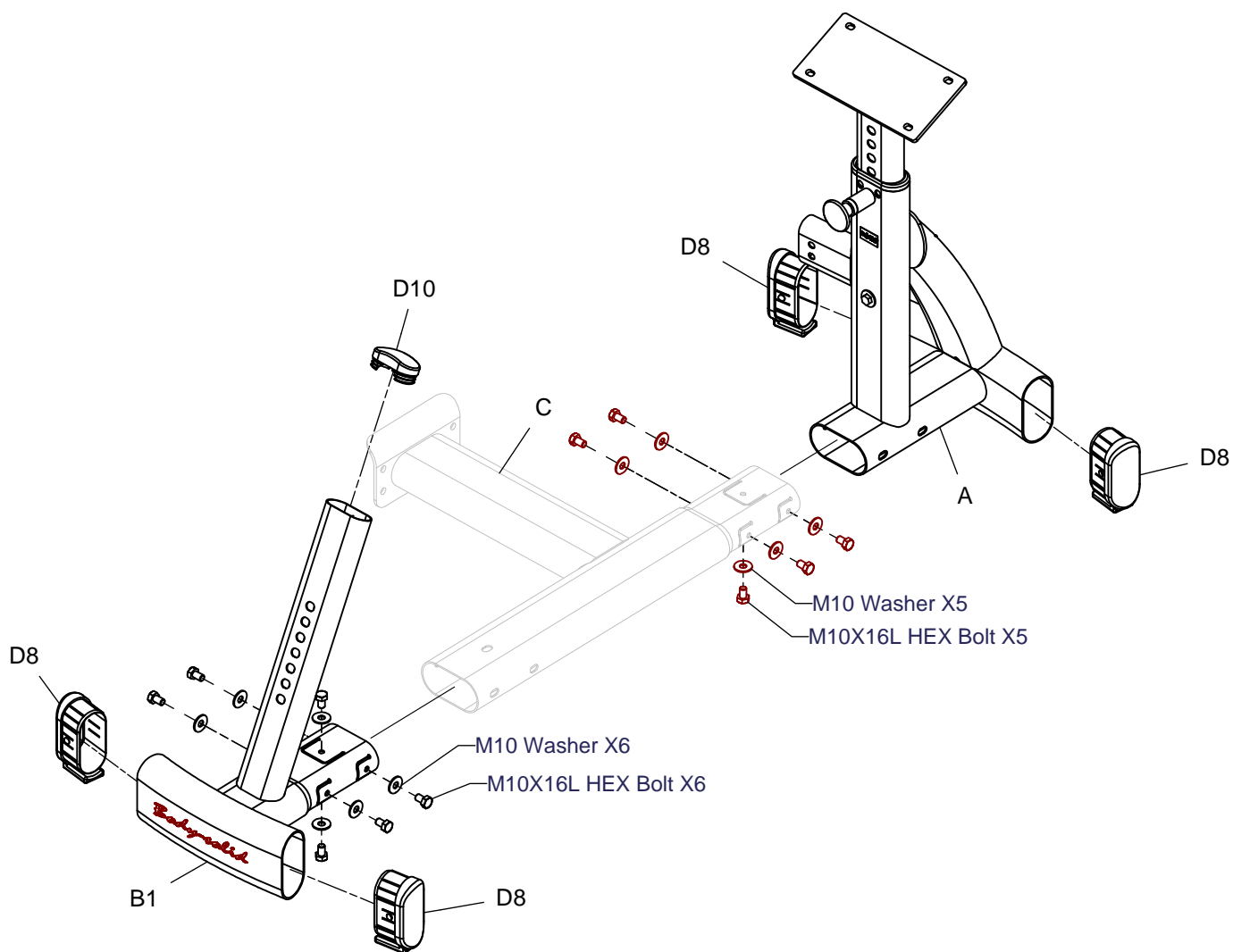

DABB ASSEMBLY INSTRUCTIONS

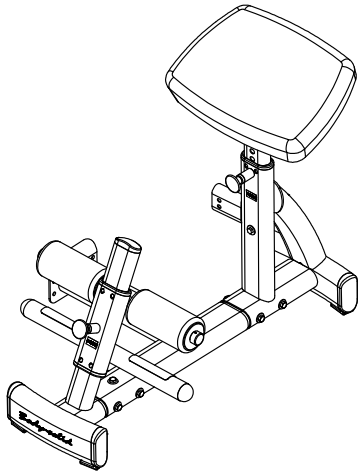

Above shows STEP 2
assembled and completed

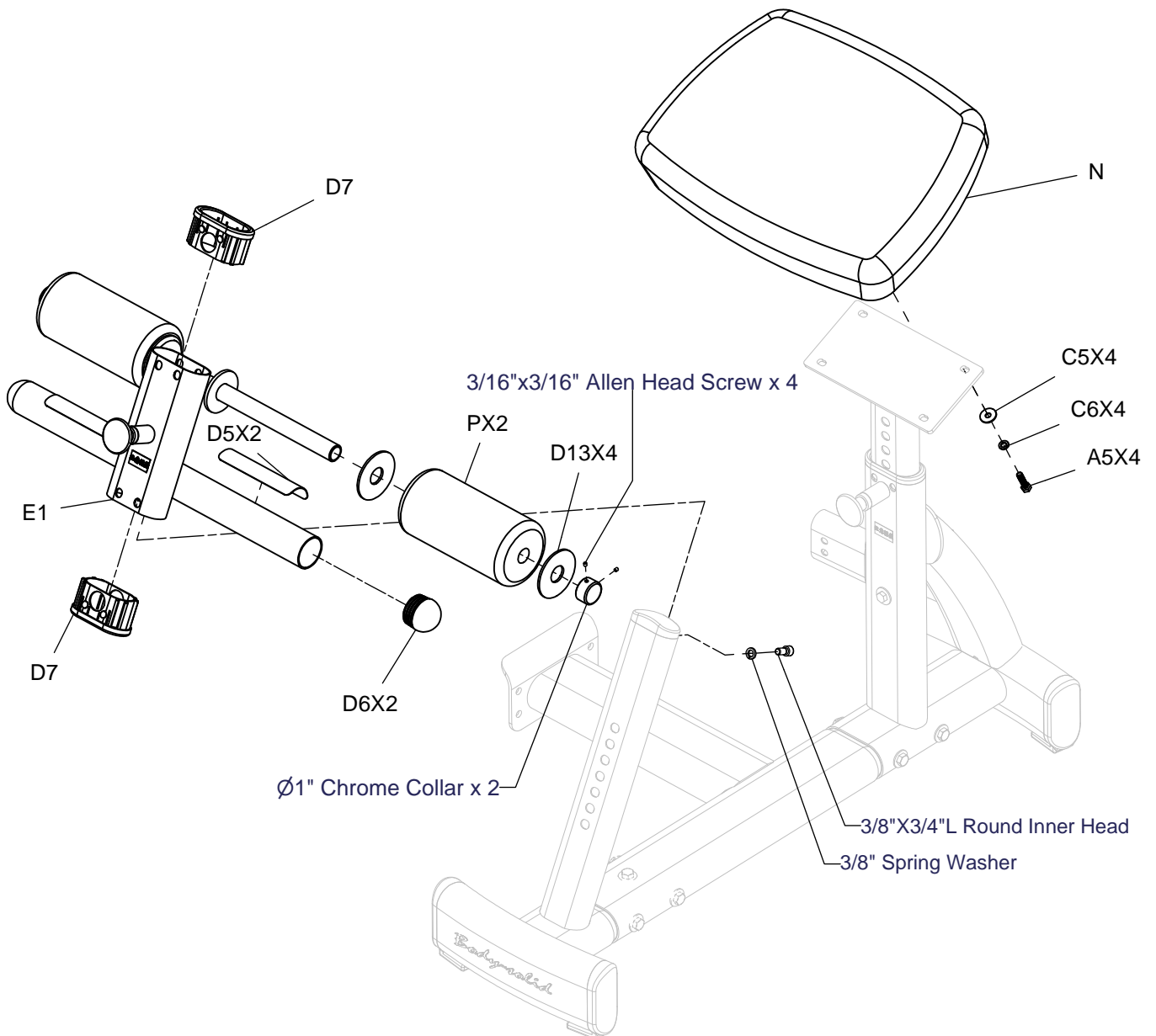

DABB ASSEMBLY INSTRUCTIONS

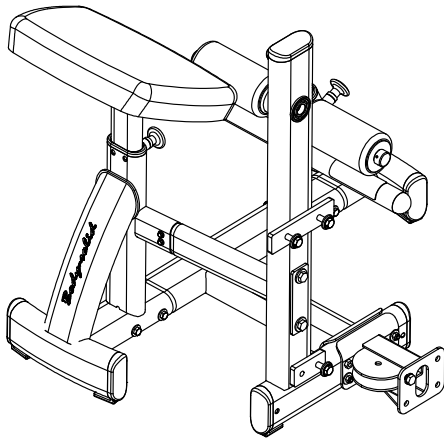

Above shows STEP 3
assembled and completed

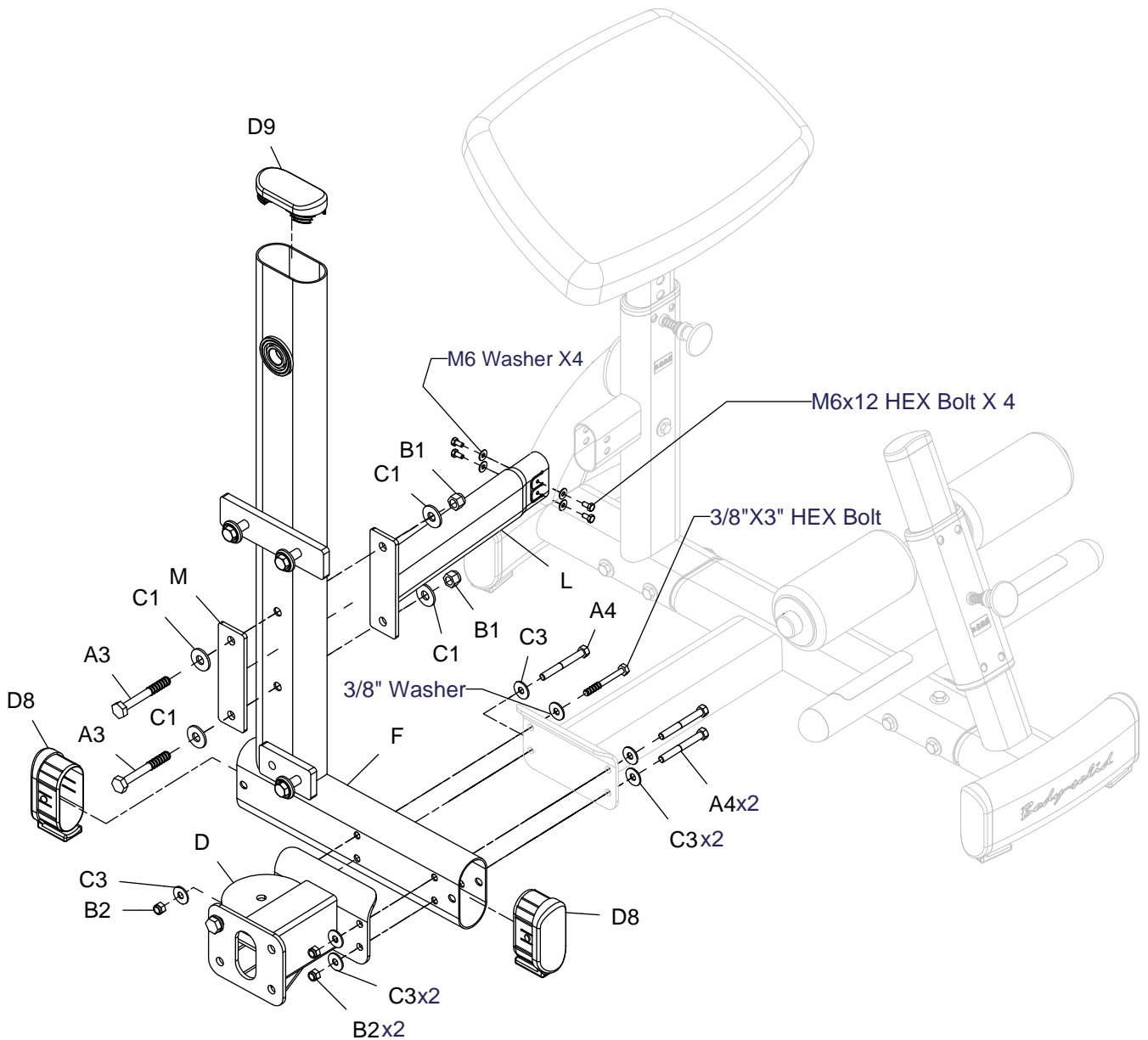

DABB ASSEMBLY INSTRUCTIONS

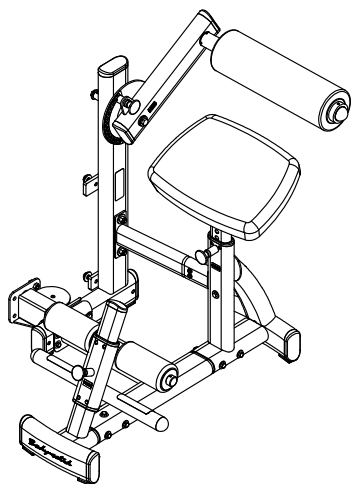

Above shows STEP 4 assembled and completed

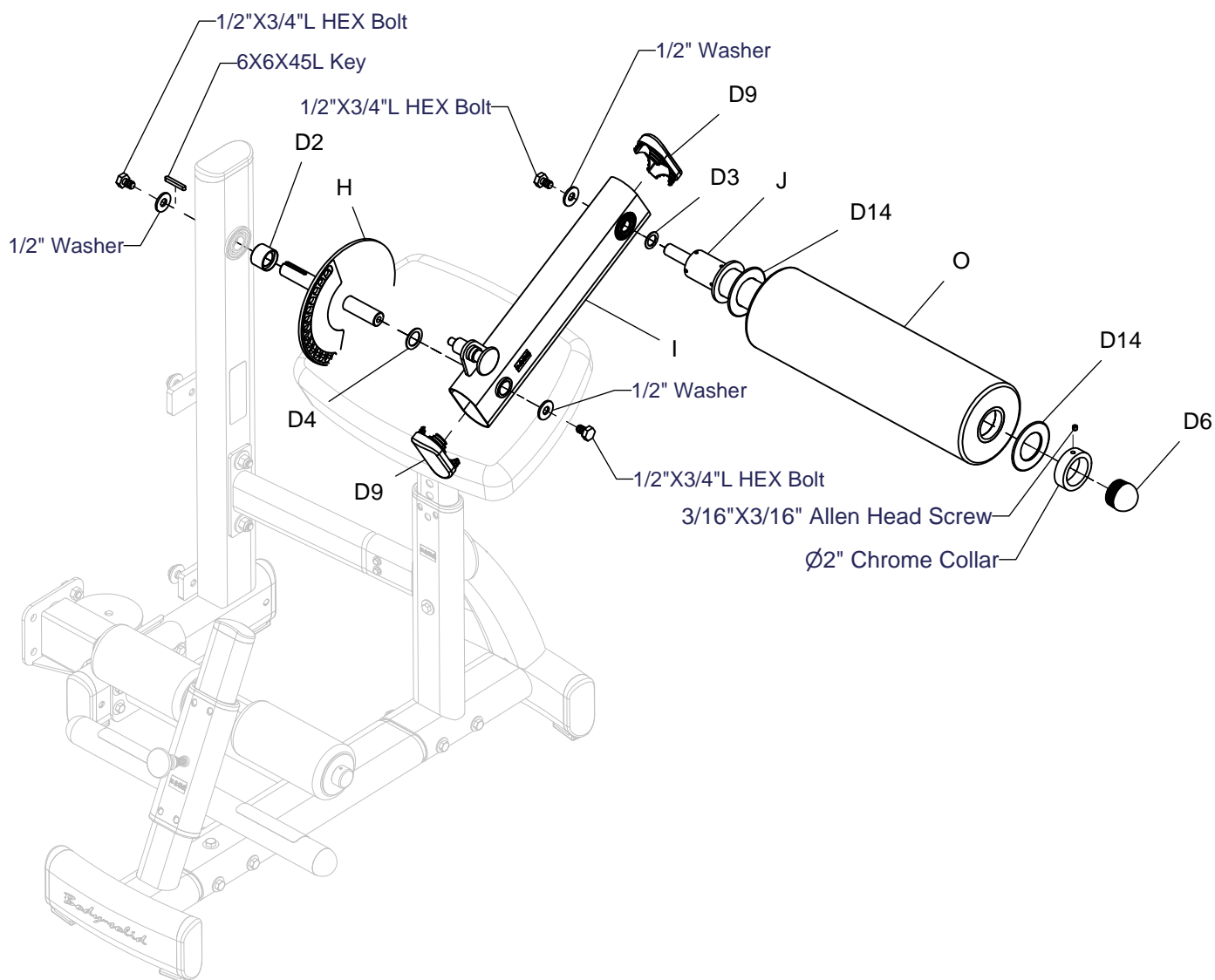

DABB ASSEMBLY INSTRUCTIONS

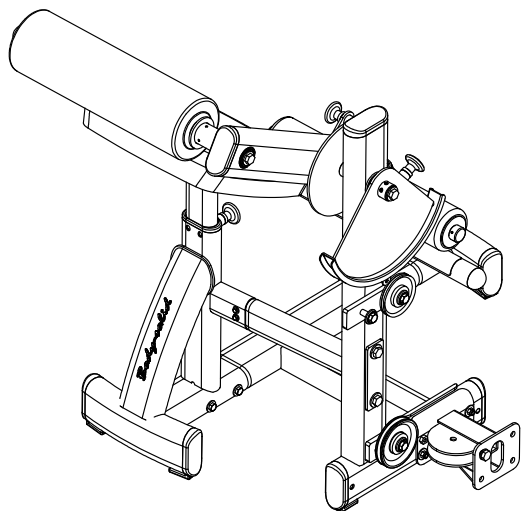

Above shows STEP 5
assembled and completed

Detail View

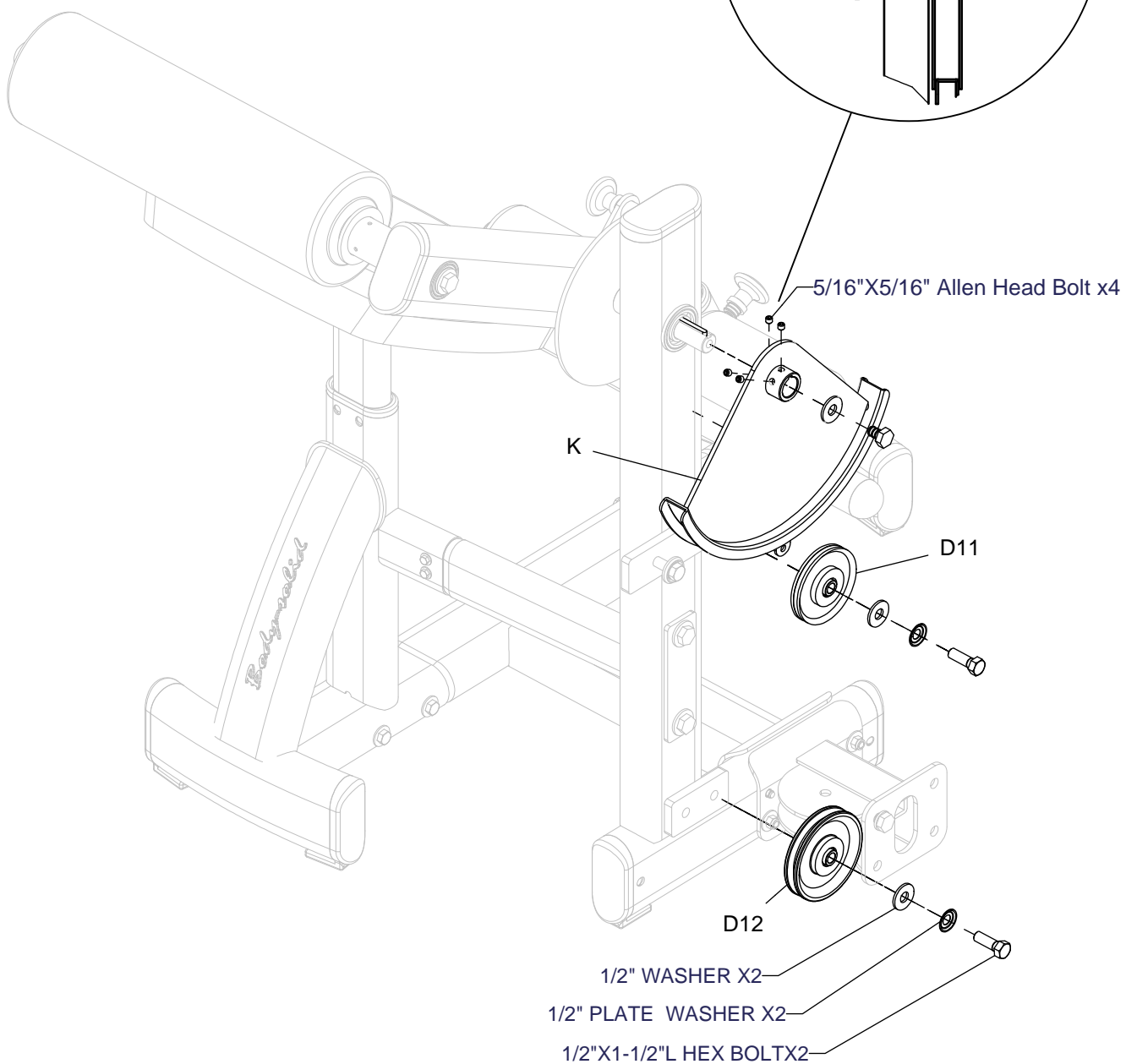
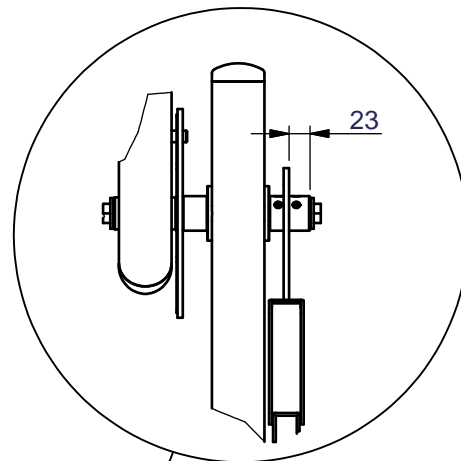

DABB ASSEMBLY INSTRUCTIONS

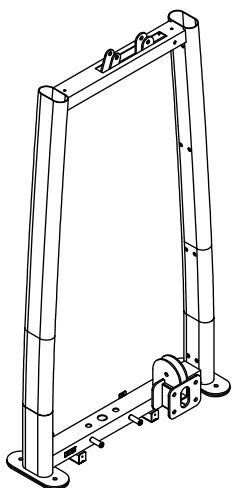

Above shows STEP 6
assembled and completed

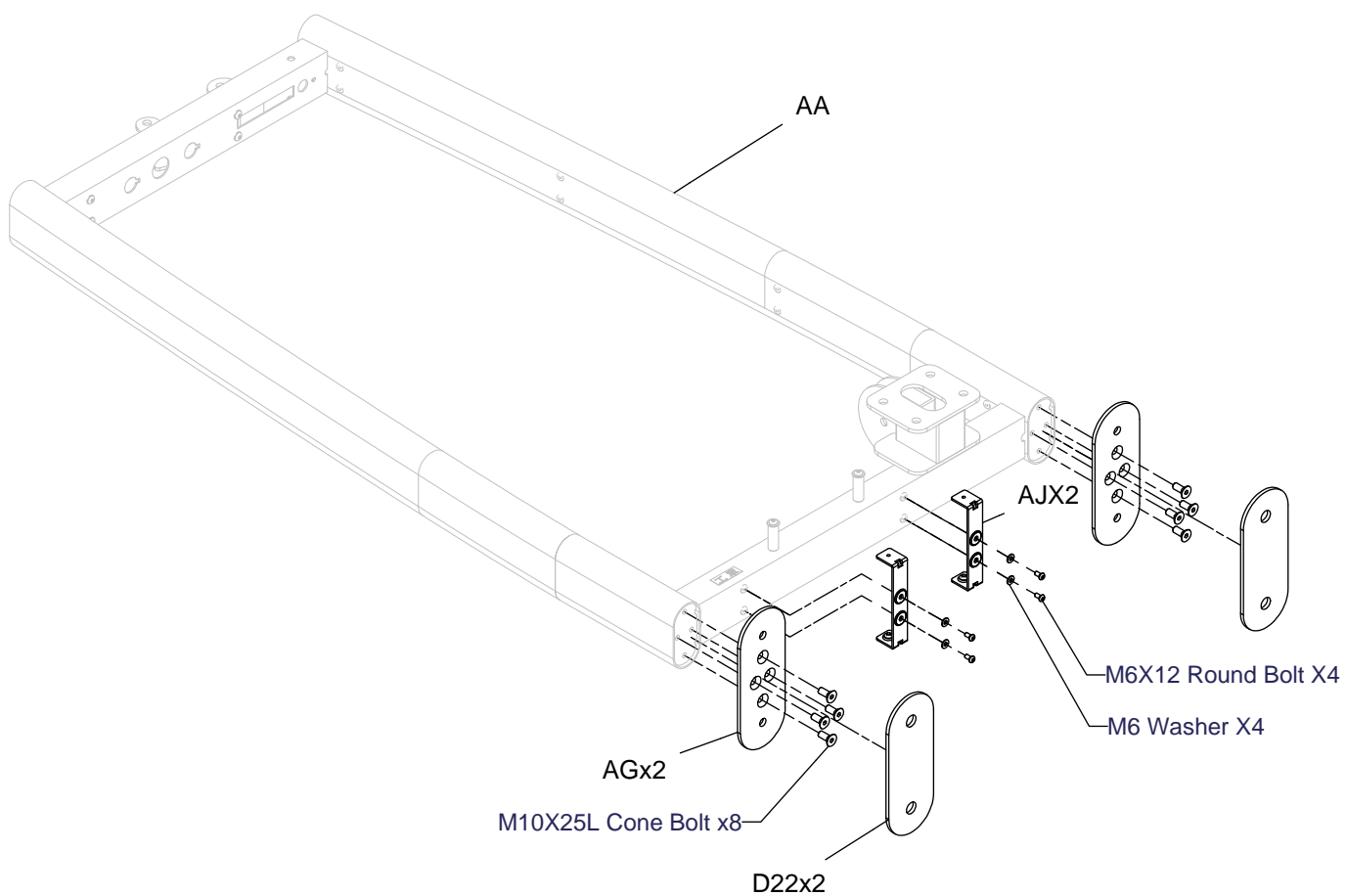

DABB ASSEMBLY INSTRUCTIONS

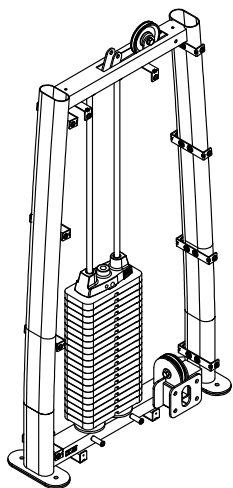

Above shows STEP 7
assembled and completed

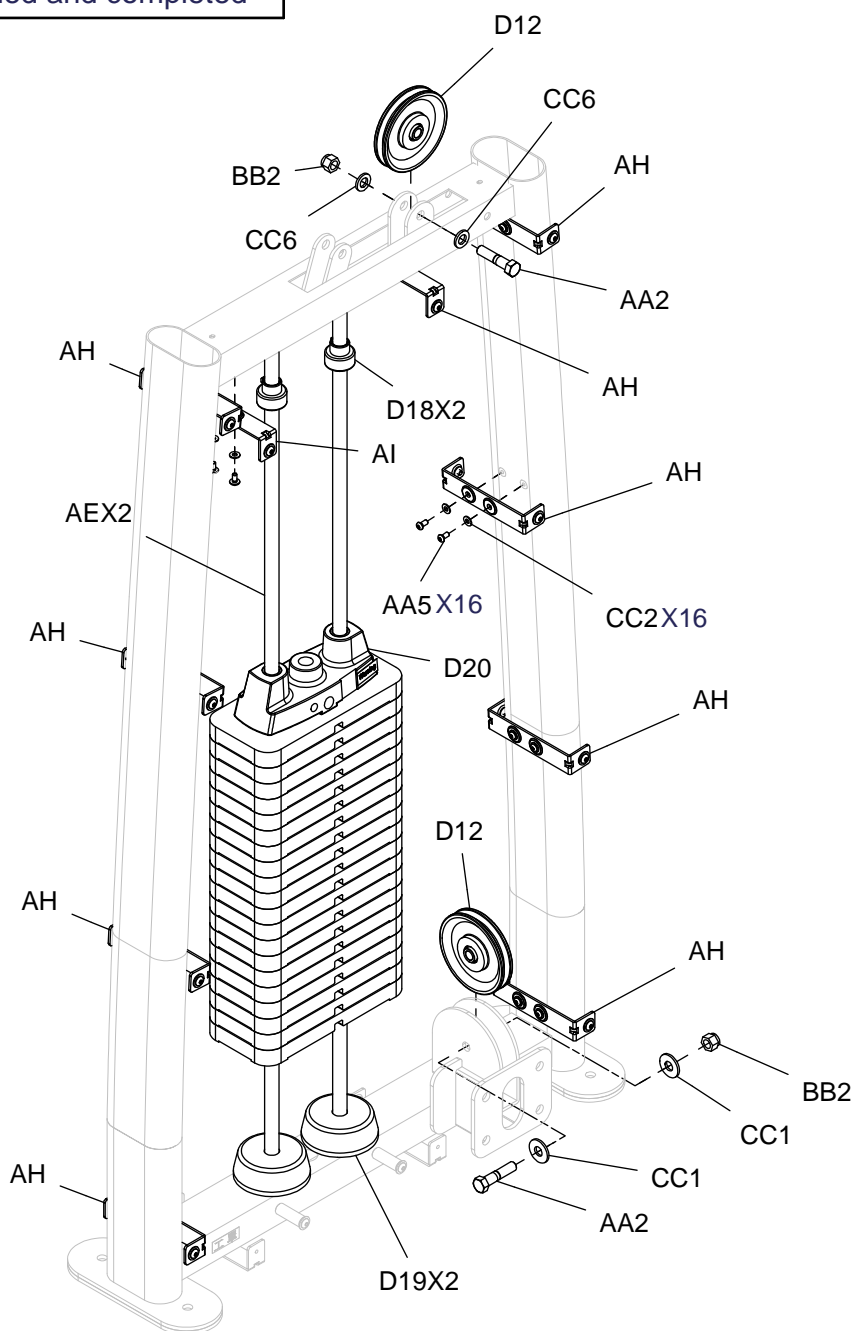

DABB ASSEMBLY INSTRUCTIONS

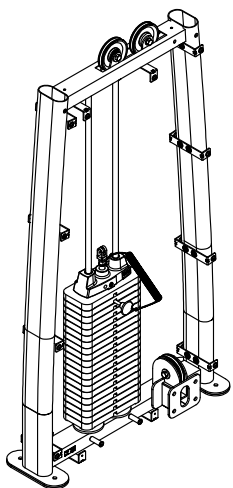

Above shows STEP 8
assembled and completed

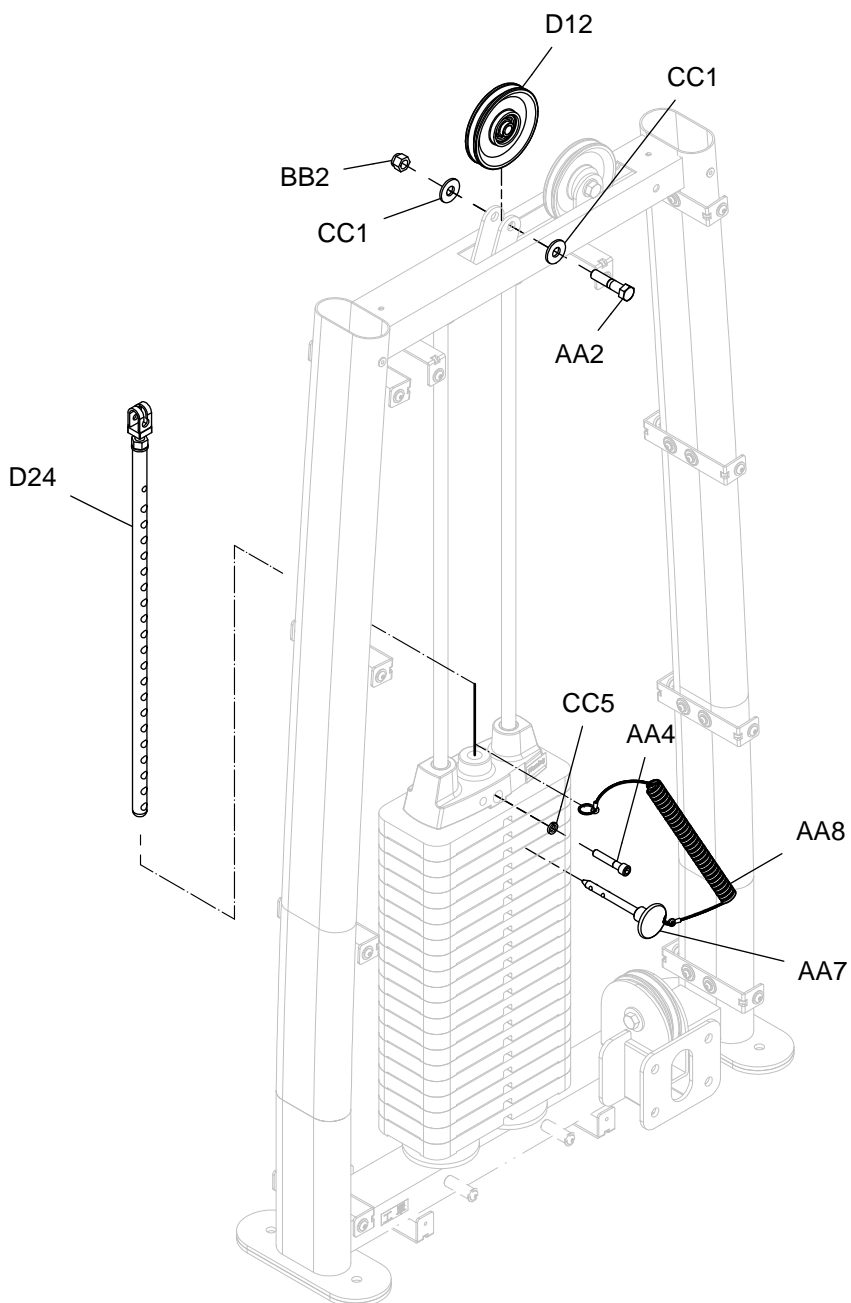

DABB ASSEMBLY INSTRUCTIONS

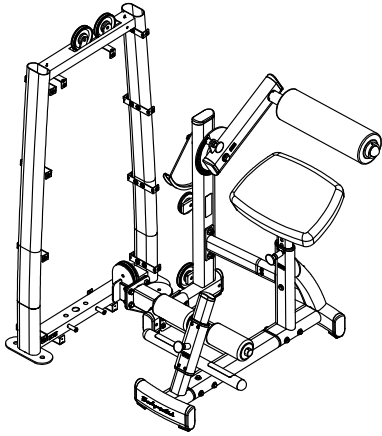

Above shows STEP 9
assembled and completed

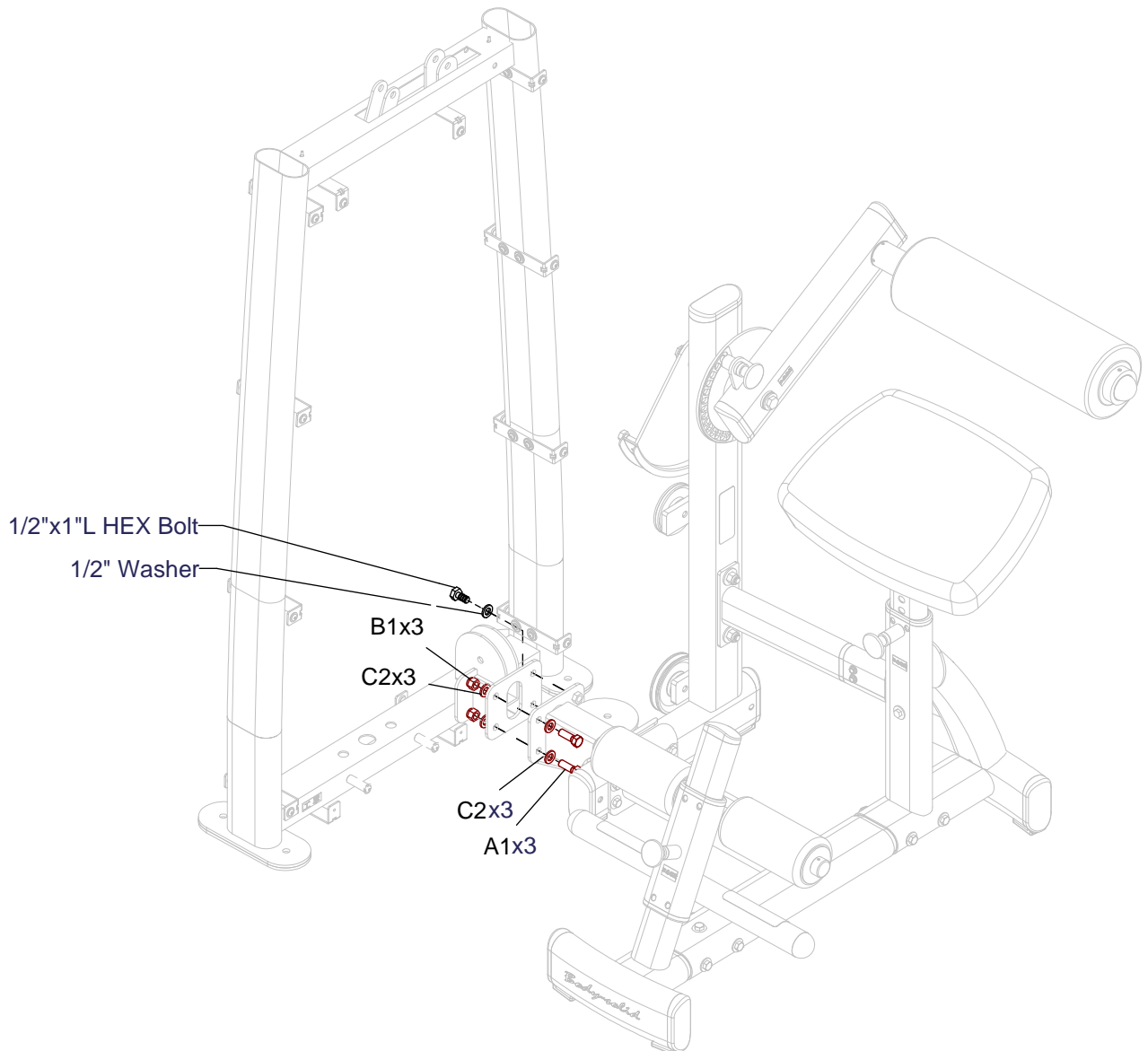

DABB ASSEMBLY INSTRUCTIONS

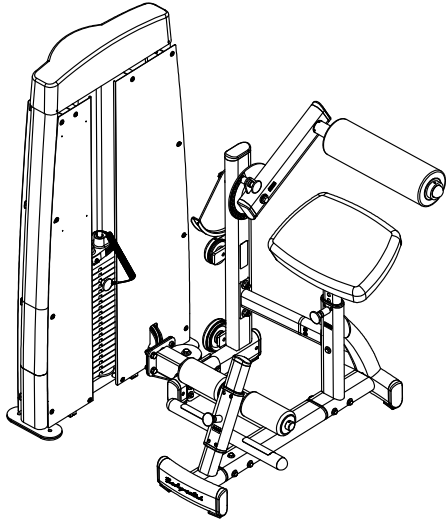

Above shows STEP 10 assembled and completed

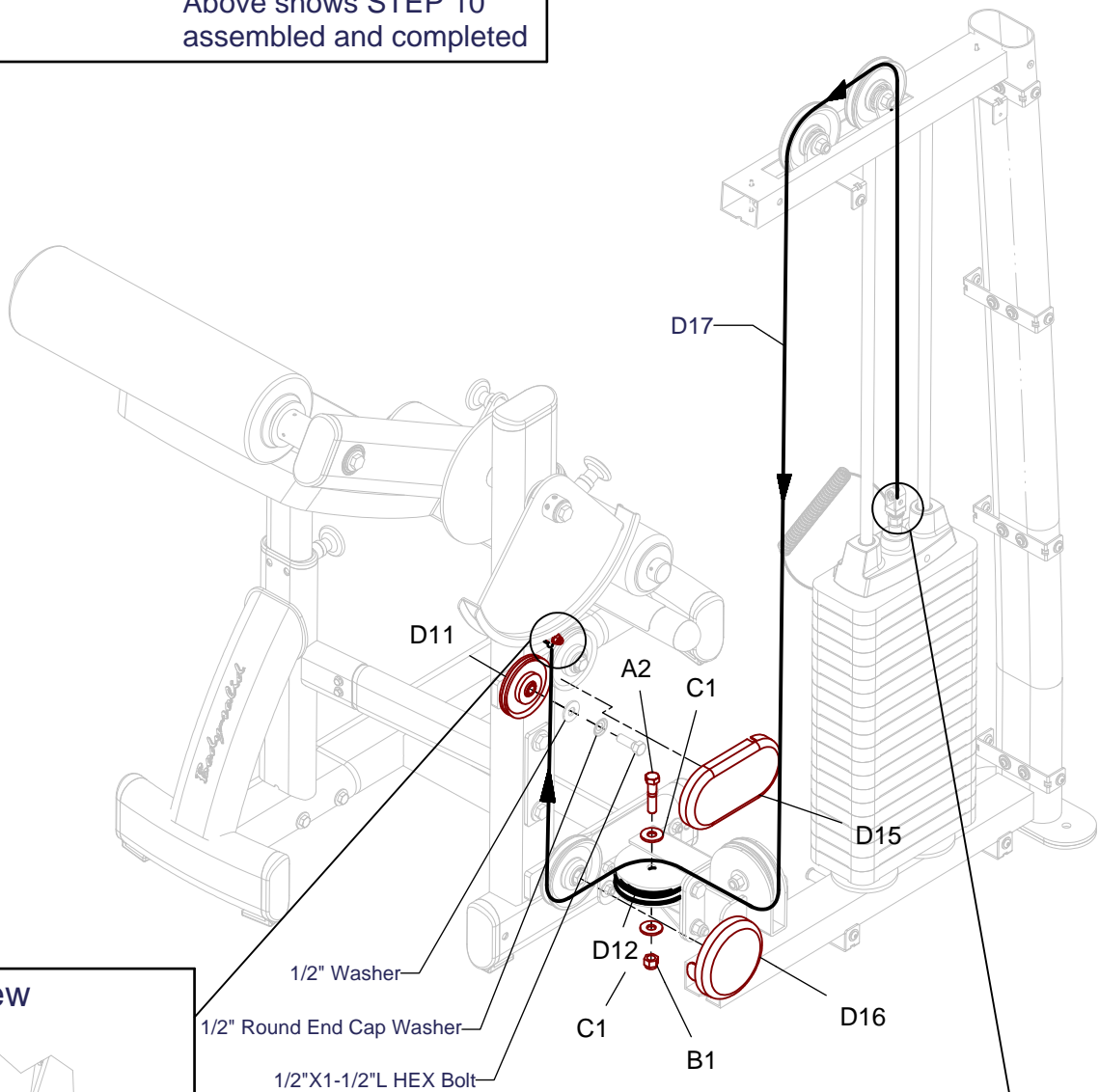

Detail View

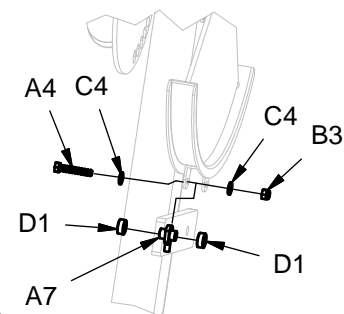

1/2" Washer
 1/2" Round End Cap Washer
 1/2"X1-1/2"L HEX Bolt

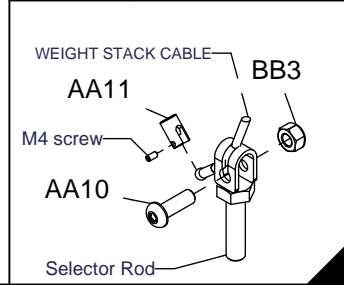
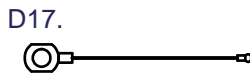

DABB ASSEMBLY INSTRUCTIONS

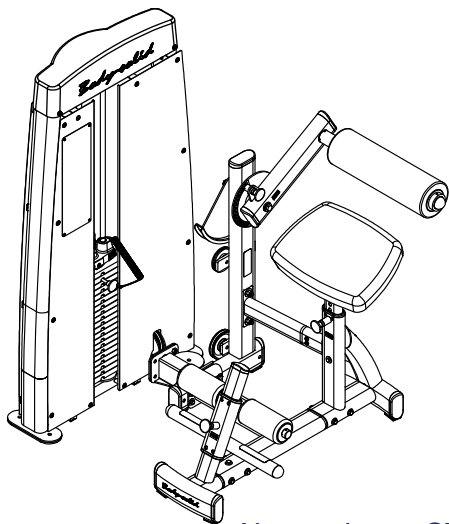

Above shows STEP 11
assembled and completed

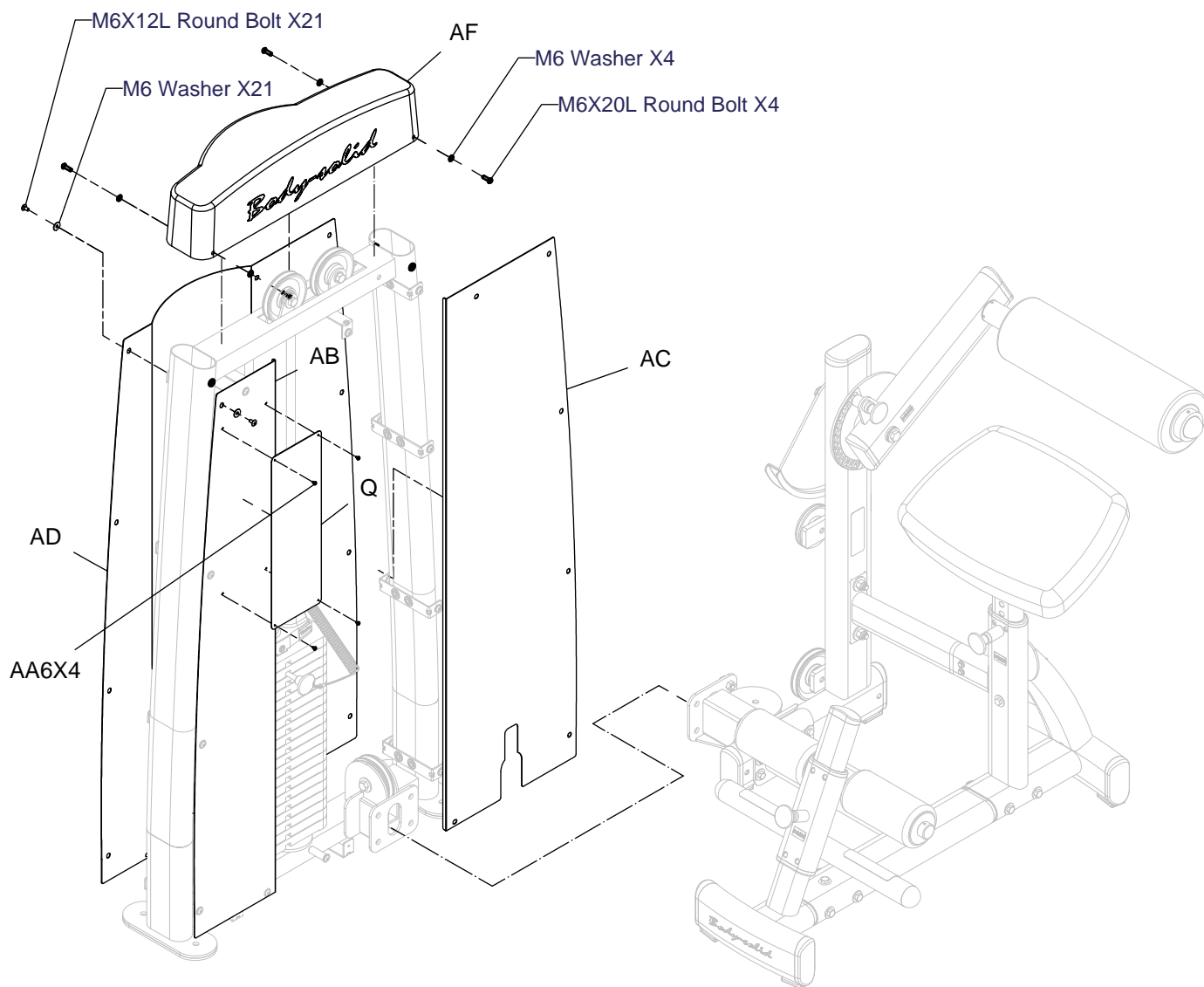

DABB ASSEMBLY INSTRUCTIONS

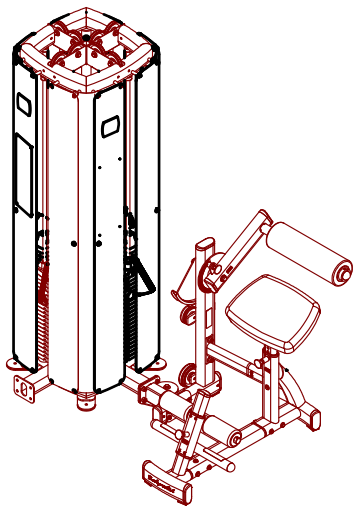

Above shows STEP 12
assembled and completed

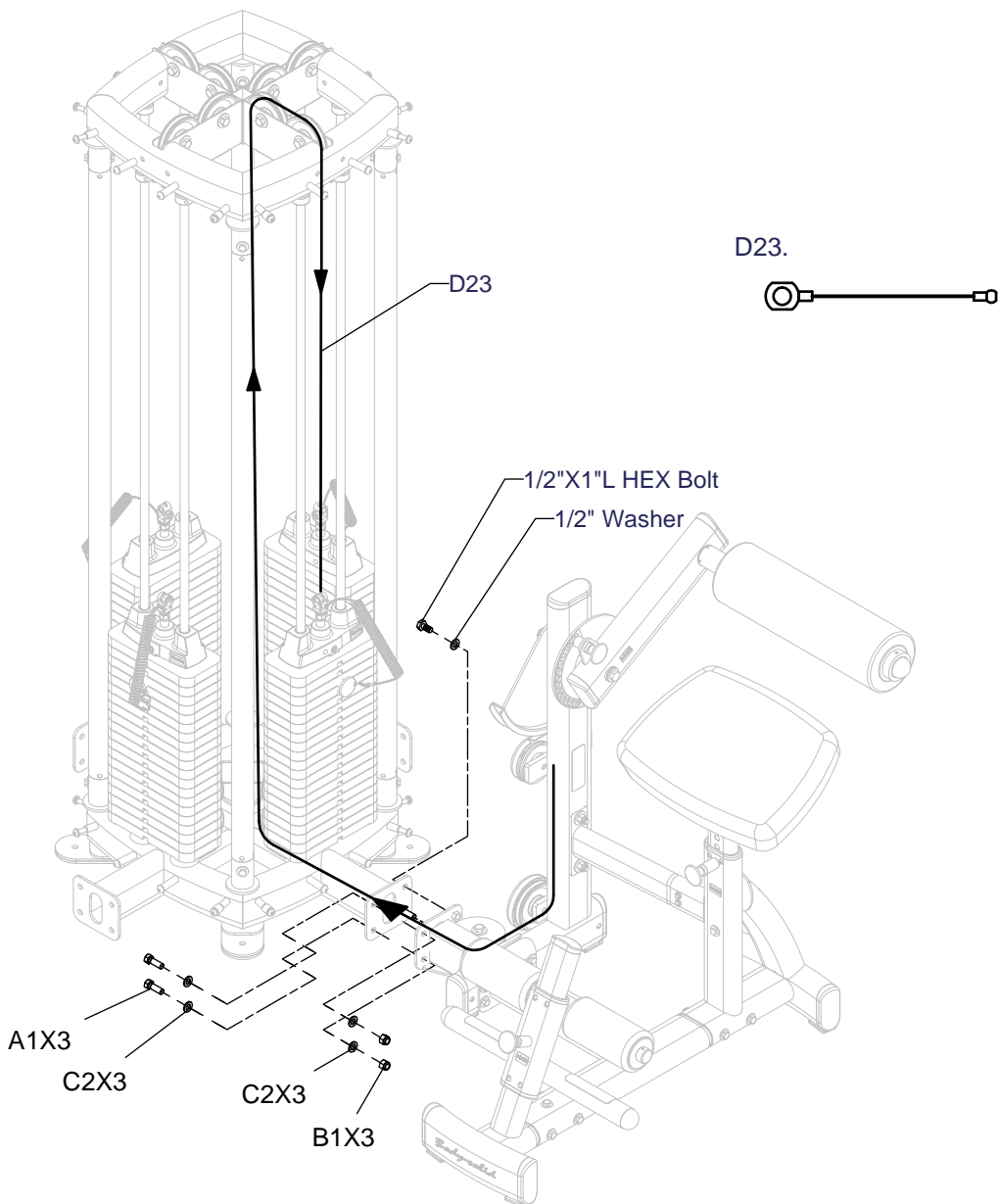

DABB ASSEMBLY INSTRUCTIONS

