

TERRABLOOM®

COPYRIGHT 2020 TERRABLOOM, LLC. ALL RIGHTS RESERVED

No part of this user manual including graphics, text and logos may be copied, reproduced, translated to any electronic or machine readable form, in whole or in part, without written permission from Terrabloom, LLC.

TERRABLOOM®

# TERRABLOOM EC FANS

USER MANUAL

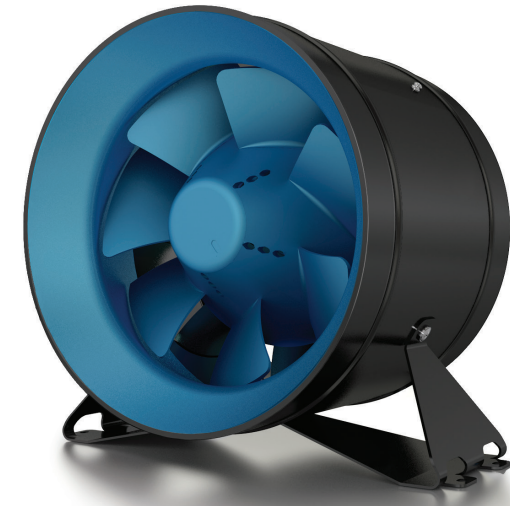

MODELS: ECMF-100, 150, 200, 250, 315

## GREETINGS FROM TERRABLOOM

Thank you for choosing TerraBloom fans for your ventilation needs. This ECMF series fan is built with a new generation EC motor which creates powerful, high-pressure airflow while saving energy. A wide range of compatible speed controllers allow you to adjust the output of this unit to fit your application.

We do our best to ensure customer satisfaction. If you have any suggestions, questions or comments, please contact us directly at [support@terra-bloom.com](mailto:support@terra-bloom.com) or through our contact form at [www.terra-bloom.com](http://www.terra-bloom.com). We are located in sunny Southern California and reply to your messages Monday-Friday, 9am-5pm PST.

## FAN APPLICATIONS

ECMF series fans generate powerful directional airflow required for a variety of commercial and residential applications. Our fans can be used in, but not limited to:

- Indoor temperature and humidity management in rooms, attics, crawl spaces
- Boosting airflow in AC and heating ducts to reach remote rooms
- Indoor farms and hydroponics
- Drying applications
- Air filtration, VOC and airborne pathogen control (when used with a matching carbon filter)
- Creating negative pressure environments
- Wind simulation
- Art installations
- Any application requiring strong directional air movement

## PRODUCT CONTENTS



- Duct fan
- Digital speed controller for 8 pre-set levels (0-10V)
- Variable dial speed controller for granular speed selection (potentiometer)
- 1ft DIY speed controller cable
- 16ft speed controller cable (TRRS 3.5mm jacks)
- Mounting hardware

## FAN COMPONENTS

- Intake wind circle
- Mixed flow fan blade
- EC fan motor (brushless DC type)
- Stator blade
- Power control board (PCB) with PWM and 0-10V support
- Metal case with IPX4 ingress rating
- Mounting bracket

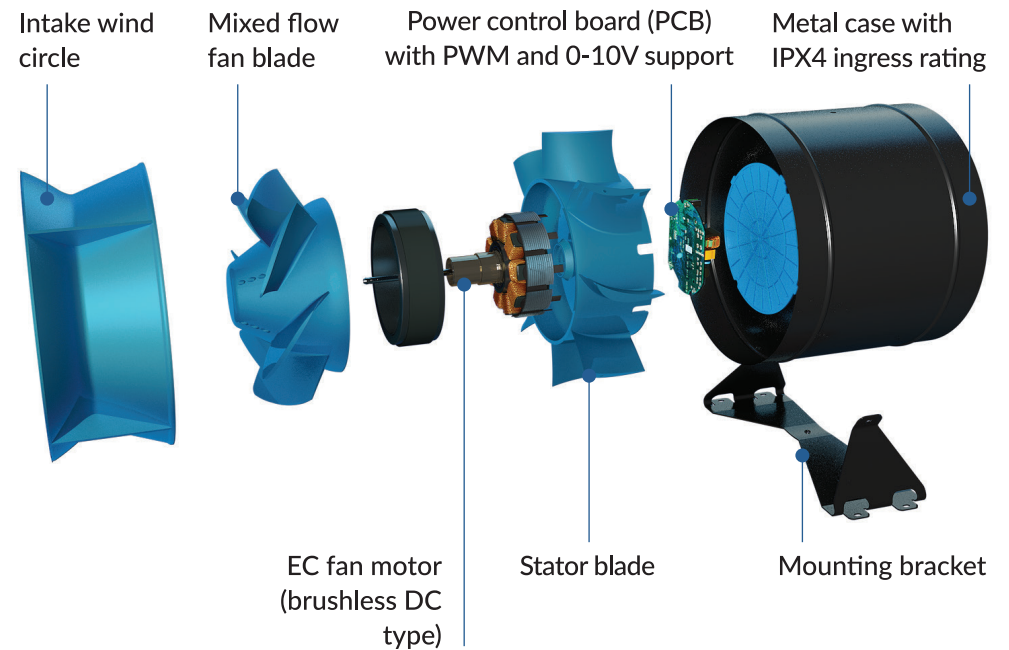

## OPERATING ENVIRONMENT REQUIREMENTS

- This fan is intended and rated for indoor use only.
- Operating temperature range: -5°F - 140°F (-20°C - 60°C). Humidity range: 0-90%.
- Not suitable for applications in close proximity to open flame (wood or gas burning) furnaces. Temperatures over 140°F can cause permanent damage to electronic components.
- Not suitable for environments with flammable or hazardous substances, explosive gases or chemical dust.
- In environments with high dust or debris content, use a pre-filter to prevent dust, grease and other foreign substances from building up on the fan blades. Debris buildup leads to mechanical damage, increased vibration and noise.

## INSTALLATION

- Inspect fan for shipping damage before installation. Ensure that the fan blade rotates freely without touching the housing.
- Securely attach the fan to a hard surface using the pre-installed mounting bracket and screws designed for the surface type in your application.
- Do not install on hollow drywall. Mount to hard surfaces (i.e. wood, concrete, metal).
- If used with securely installed carbon filters, it is acceptable to install the fan on top of the filter's duct collar. Secure the connection with a duct clamp.
- In grow tent application, it is acceptable to have the fan securely suspended from the tent's metal frame. To suspend the fan, use ratchet hangers or heavy-duty zip-ties.

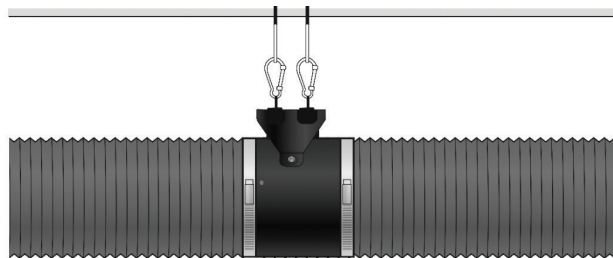

## APPLICATION TIPS

- The ducting has a strong effect on the air flow, noise and energy use of the fan. Use the shortest, straightest duct routing possible for best performance, and avoid installing the fan with smaller ducts than recommended. Insulation around the ducts can reduce energy loss and inhibit mold growth. Fans installed with existing ducts may not achieve their rated airflow.
- A duct of matching size with the fan inlet and exhaust is recommended for best performance. Ensure duct joints and exterior penetrations are sealed with caulk or other similar material to create an air-tight path and to minimize building heat loss and gain and reduce the potential for condensation. Place/wrap insulation around duct and/or fan to in order to minimize possible condensation buildup within the duct, as well as minimize building heat loss and gain.
- When installed vertically and connected to the outdoors via a duct, use a vent cap with a loaded damper to protect the fan and duct from the outdoor elements.
- Install the fan at least 6ft above the floor to keep it out of reach of children and pets. For added safety, use metal grills/guards to keep the fan's moving parts from the reach of children and pets.
- After installation, perform a test run to confirm that the fan operates as intended. A speed controller must be connected to the fan before power up.
- Once powered on, the fan blade should rotate freely and accelerate gradually.
- If excessive noise is present, verify that there are no foreign objects (duct pieces, screws, etc.) touching the fan blade. Secure installation to a hard and stable surface is key to avoiding vibration and excessive noise.
- This fan can be installed in a horizontal or vertical position.

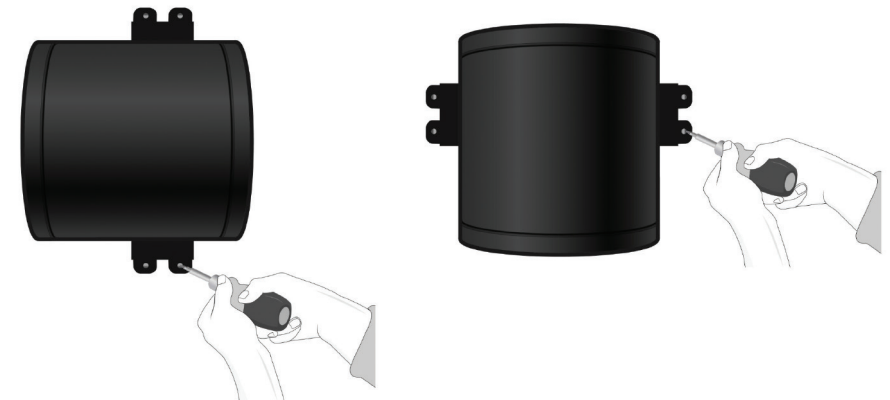

## FAN OPERATION WITH SPEED CONTROLLER

- You must use a speed controller in order to operate this fan. The fan will not start if it is not connected to a compatible speed controller.
- Your purchase includes two speed controllers in addition to the fan. Only one speed controller can be used with the fan at a time. Multiple speed controllers cannot be connected simultaneously.
- **Controller 1 – 8 speed digital speed controller.** Each press of a button on the controller increases the speed by 1 level or 12.5%. Speed level 1 = 12.5% of maximum speed, Level 2 = 25%, Level 3 = 37.5%, Level 4 = 50%, Level 5 = 62.5%, Level 6 = 75%, Level 7 = 87.5%, Level 8 = 100% (maximum speed).
- **Controller 2 – Granular variable speed controller.** Variable dial speed controller is a potentiometer type speed controller which allows for granular speed adjustment. To increase the fan’s speed turn the dial clockwise, to reduce the speed, turn the dial counter-clockwise.

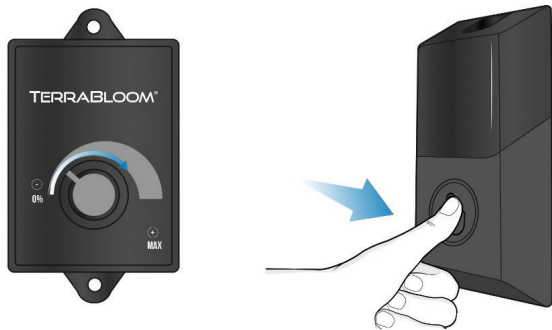

- To prepare fan for operation, attach your preferred speed controller to the fan before power on.

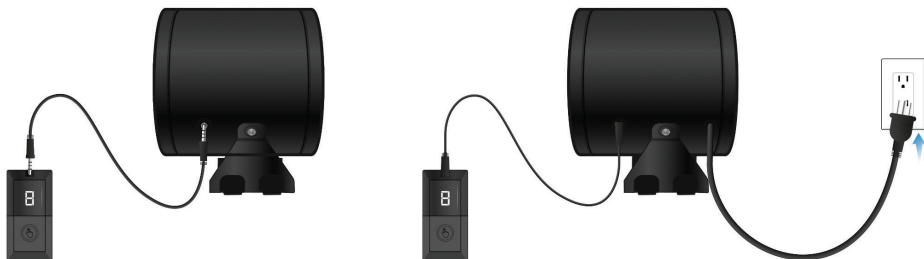

- This fan is rated for continuous use and can be operated 24/7.

## OPTIONAL SPEED CONTROLLERS

- TerraBloom offers a programmable thermostat speed controller with a temperature probe (Model: SC-ECMF) and a wireless remote speed controller (Model: ECMF-WR).
- PWM controllers (Arduino, Raspberry PI, etc.) use the frequency range of 15-32kHz and voltage range of 10-12V.
- If used with a third party speed controller, use the provided TRRS 3.5mm connection wire or a DIY speed controller wire with pin outputs to connect the fan with the controller
- Refer to the illustration below for a description of pin outputs on the DIY speed controller wire.

## DIY SPEED CONTROL WIRING DIAGRAM

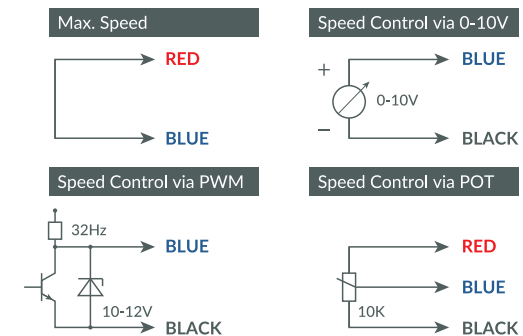

## DIY SPEED CONTROL OUTPUT PINS

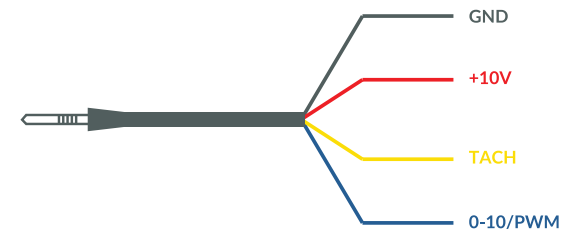

## NOTE ON FAN OUTPUT AND STATIC PRESSURE

- The CFM rate stated on the fan is a “nominal” airflow rate and is applicable only when no additional equipment is attached to the fan.

MODEL	DUCT DIAMETER	POWER USE @ 0” W.G	MAX AIRFLOW	MAX PRESSURE	MAX SPEED
ECMF-100	4” (OD 98mm)	18W	160 CFM	1.34” W.G.	5000 RPM
ECMF-150	6” (OD 150mm)	40W	350 CFM	2.01” W.G.	5000 RPM
ECMF-200	8” (OD 200mm)	75W	710 CFM	2.09” W.G.	3200 RPM
ECMF-250	10” (OD 250mm)	126W	946 CFM	1.65” W.G.	3200 RPM
ECMF-315	12.3” (OD 312mm)	268W	1662 CFM	1.86” W.G.	2800 RPM

- When you attach any equipment to the fan (ducts, vent caps, filters, splitters, elbows, etc.) you are introducing static pressure, an obstacle in the path of the airflow. This will cause the final amount of airflow delivered by the fan to be lower than the nominal airflow.
- Each duct fan has a maximum pressure rating which equals to the maximum static pressure it can counteract in order to move a certain volume of air.
- To achieve optimal results, you must take static pressure into consideration when choosing the inline duct fan to use in your application.
- A pressure drop is the amount of static pressure introduced by a filter or any equipment attached to the fan.
- To find the precise value of airflow produced by a fan in a particular application, refer to our web-site for the pressure curve of your fan model. The pressure curve shows the CFM output of the fan at different pressure levels. Once you calculate the amount of pressure created by all of the equipment attached to the fan, locate that pressure level on the pressure curve to pinpoint the corresponding CFM output.
- If the pressure drop and/or pressure curves are not available, assume that the carbon filter will reduce the amount of airflow by 30-40% from the nominal airflow rate stated on the fan. The thicker the carbon bed, the higher the pressure drop. When using ducts to connect the fan and filter, please factor an additional airflow reduction of 3% (smooth metal duct) to 7% (flexible ribbed duct) for every 25ft of duct. 90° turns in ducting cause an additional 1%-4% reduction in airflow.

## FAN MAINTENANCE

- Use a damp cloth to remove dust and debris build up from the fan’s components every 6-12 months.
- To avoid mechanical damage, do not apply pressure to the fan blades.

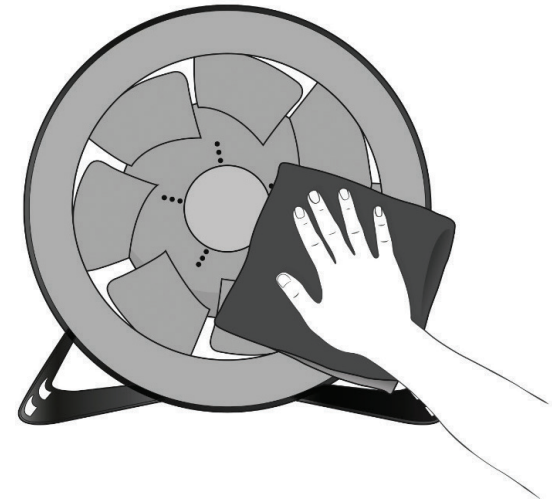

## WARRANTY

ECMF series fans are covered by a 2 year warranty from the date of purchase against any defects in workmanship or materials. Under warranty, the fan will be either replaced or repaired and must be accompanied by proof of purchase. The warranty doesn’t apply to any damage caused by excess heat or humidity, misuse in harsh industrial environments, physical damage or normal wear and tear of the unit.

## CONSIDER THE FOLLOWING TERRABLOOM ACCESSORIES FOR USE WITH ECMF FANS

(PRODUCTS SOLD SEPARATELY)



### CARBON FILTERS

Odor, airborne debris and dust filtration in indoor growing applications.



### LIGHTPROOF FLEXIBLE AIR DUCTING

Quick and easy way to connect your ventilation equipment.



### SMART SPEED CONTROLLER

Manage speeds of up to 4 TerraBloom EC fans simultaneously. Supports manual and programmable auto modes. Comes with thermal probe for accurate monitoring of the surrounding environment.



### WIRELESS REMOTE WITH RECEIVER

Allows you to control your TerraBloom EC fan wirelessly. 6 pre-set speed levels (15-100% output). 50ft signal range, which works through walls, floors and ceilings. Ideal for fans installed in hard to reach places.