

THIS TAG IS NOT TO BE REMOVED EXCEPT BY THE CONSUMER

WARNING

Seat belts should never be attached to the seat unless the vehicle manufacturer clearly indicates that the seats and seat mounting systems have been specifically designed to withstand seat belt assembly loads. Always use factory installation points when available. Electric seat belt systems will not work with these seat belts.

This seat belt assembly is for replacing factory seat belts in 1974-77 Chevrolet Corvettes.

The information presented in these instructions is not intended to conflict with the information found in Federal Motor Vehicle Safety Standards FMVSS 209, 210, and 302.

Install seat belts per SAE Recommended Practice J800c and Vehicle Manufacturer's Instructions.

Installation Guidelines

1. Mount the buckle side of the seat belt (A) at the inboard side of the seat to the factory anchor point.
2. Mount the lap belt retractor (B) to the factory mounting point underneath the seat.
3. Install the D-Ring (C) on the b-pillar, and the retractor (D) in the factory mounting point behind the seat with

the buckle side of the seat belt fed around the outboard side of the seat (Figure 2). Repeat these steps for the passenger side.

Figure 1

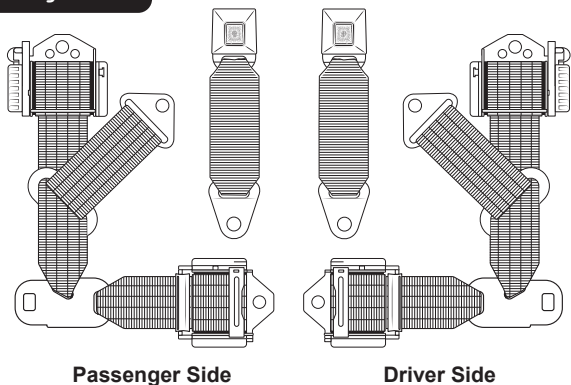
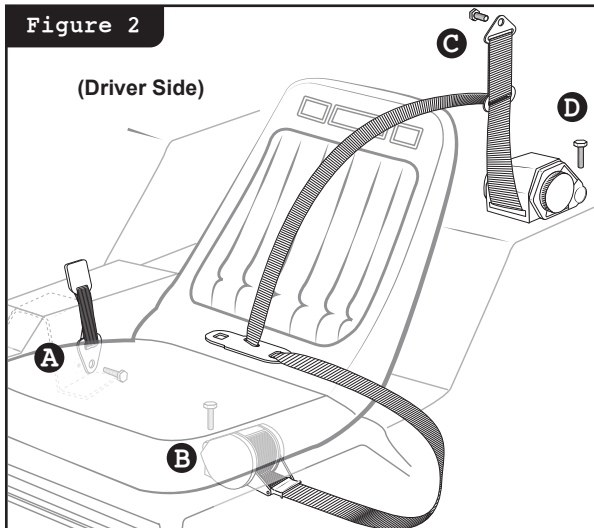

Figure 2



Factory Mounting Locations: A = Seat Belt Buckle, B = Lap Belt Retractor, C = D-Ring, D = Shoulder Belt Retractor



www.RetroBelt.com

Figure 3

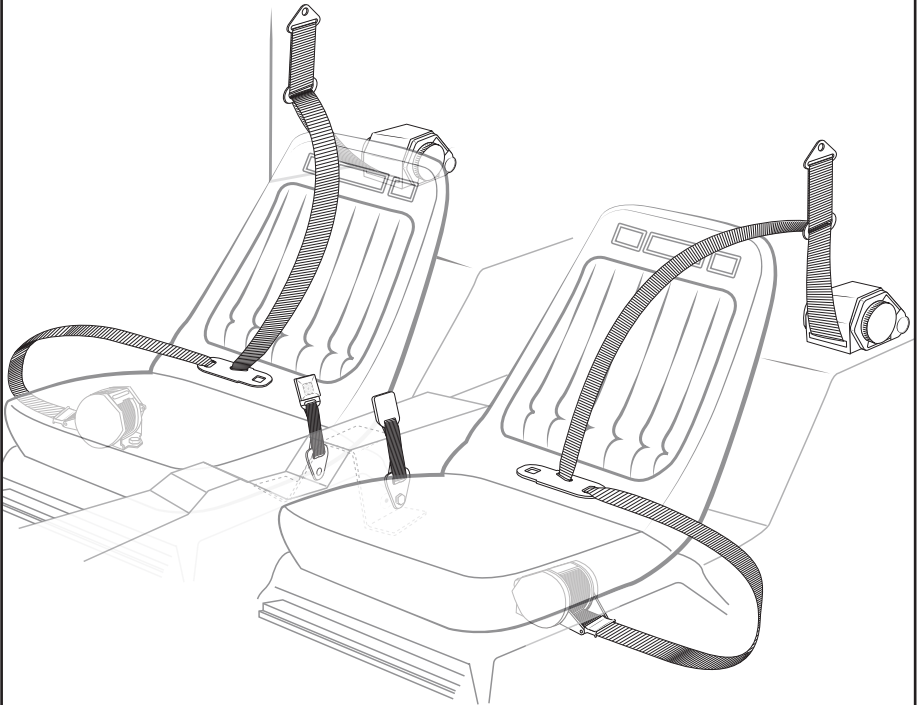

Finished Installation



Modern Safety for Your Classic

www.RetroBelt.com