

VERONA SERIES

V-560

Modular Refractory Pizza Oven Kit

| Professional COMMERCIAL Wood Fired Oven

| Made in USA Since 2005

INSTLATION MANUAL FOR VERONA 560 OVEN BY: CALIFORNO, THE BETTER PIZZA OVEN!

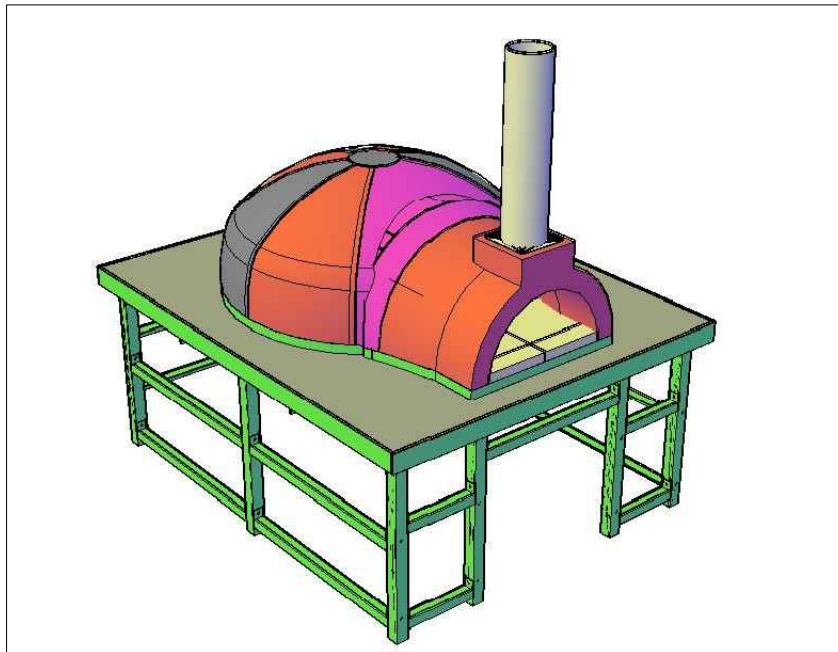

EXTREMELY IMPORTANT:
YOU MUST FOLLOW OUR OVEN CURING
INSTRUCTIONS TO AVOID CRACKS IN YOUR OVEN!!!

SEE NEXT PAGE AND ALSO LAST PAGE AS A
REMINDER

VERONA 560 installation

www.californo.co | 855.55.forno (36766) | info@californo.co
209 NW 4th Ave. Hallandale Beach, Florida 33309

CALIFORNO

THE BETTER PIZZA OVEN

© 2016 V 1.8

Curing Your Oven Instructions for Curing Your Pizza Oven

Follow these instructions to cure your pizza oven. Curing your oven is critical to your pizza oven's performance. **Failure to follow these instructions can result in damage up to and including cracking the dome**, severely impacting heat retention.

NOTE: For ovens with Gas burner, there are shortcuts to the curing process you can find in the Installation Manual. A Californo technician can be made available through our contact form to help walk you through some tricks to make this easier.

1. Why is proper curing so important?

Like with any concrete items there is always excess water that is evaporating overtime from product to the outside air. In a conventional concrete products it can take up to 360 days to get the very inside of the concrete 100 cure. Curing your oven components will get it to the maximum strength when done properly. However, fast curing will cause the all amount of water to escape simultaneously and may result in cracking the dome. Also, after you've complete your oven installation, there is still a great deal of moisture in the mortars, hearth concrete, vermiculite, and the oven chamber and manifold. Each of these oven components was produced in our facility and got dry by air only. Simply letting the oven stand for a week or month will not cure the moisture out of the oven.

2. Can I cure the oven dome without installing the insulation and decorative facade?

Technically you can, but it is not recommended for a few reasons:

- Without insulation, it can present a fire and safety hazard;
- After curing, your oven will reach higher temperatures than before it was cured. It will reach 1000 deg F, that mean if you cure your oven at first and later do your stucco, there will be water that try to escape the stucco which will crack it.

3. When can I start my curing process?

Before you start the curing process, let the complete oven sit for 5 days. Regardless if it was raining or not during that time rain will help strengthening your oven. If you purchased a fully assembled pizza oven from Californo, you may start the curing process of your oven without waiting the 5 days, as naturally 5 days has passed from the day we completed the assembly until you received the oven so that mean you may start the curing of your assembled oven the day you received it.

4. How do we cure the oven? *Important Note:*

It is critical for proper curing and avoiding damage that you do not go above these temperatures shown below during the first two days.

It is important that you cure your pizza oven slowly over a 5 day period. You build a series of five increasingly larger fires, starting with a low temperature (see below). The first-day fire is no more than kindling and thin strips of wood.

Curing Your Oven Instructions for Curing Your Pizza Oven

1st Day: 300° F for 5 hours minimum.

Start and maintain the fire in the center of the dome, not on the perimeter of the oven. **You don't want the fire to get too high and touch the dome.** You should leave the door partly open allowing about 2" gap once the fire is lit that will help direct the smoke up the vent as temperature is relatively low and smoke is than heavier. You should look at the analog temperature gauge if you purchased and installed one. The temperature gauge reads the oven's air temperature. For a more accurate temperature reading of the oven refractory surfaces, which can be use for many types of cooking, you can use the optional Digital Infrared Thermometer, which can be purchased in the Californo Store. You want to measure the temperature at the dome of the oven, not the side wall or floor. This will be the hottest point of the oven. The temperature can vary slightly, but try not to exceed the temperature for that day's cure schedule by more than a few degrees, better to be 20 degrees cooler than hotter. Especially on day one and two.

Close the oven door every evening to preserve dryness and heat.

2nd Day: Repeat process at 350° F (177 Celsius)

3rd Day: Repeat process at 400° F (204 Celsius)

4th Day: Repeat process at 450° F (232 Celsius)

5th Day: Repeat process at 500° F (260 Celsius)

Important Notes:

- Use solid wood fuels only.
- DO NOT use charcoal, pressure treated lumber, chipped wood products, sappy wood such as pine, laminated wood or any material other than dry medium or hard firewood.
- DO NOT USE liquid fuel (firelighter fluid, gasoline, lantern oil, kerosene or similar liquids) to start or maintain a fire.
- You can start the fire with an acetylene torch if you have one handy.
- Food grade fire starters are considered acceptable aids when starting a fire.
- Do not use products not specified for use with this oven.
- Never use water to lower the temperature inside the oven, or to extinguish the fire. This will increase wear and tear on your oven and can lead to spalling, pitting and cracking your cooking surface.
- There must be a period of time between completing the masonry work and beginning the actual firing cure.
- Longer is better than shorter, particularly for the actual dome cement.
- The cement and mortar must cure first and this process is actually improved by keeping the cement moist and not letting it dry out. (when installing the dome components, it is a good practice to cover the dome by plastic sheet to avoid the fast escape of humidity in hot climates until you apply the insulation blankets)) Space heaters should not be used to cure an oven. It will produce a high amount of steam in the oven and can become a safety hazard so it is not recommended.

VERONA SERIES

V-560

Modular Refractory Pizza Oven Kit | Professional COMMERCIAL Wood Fired Oven | Made in USA Since 2005

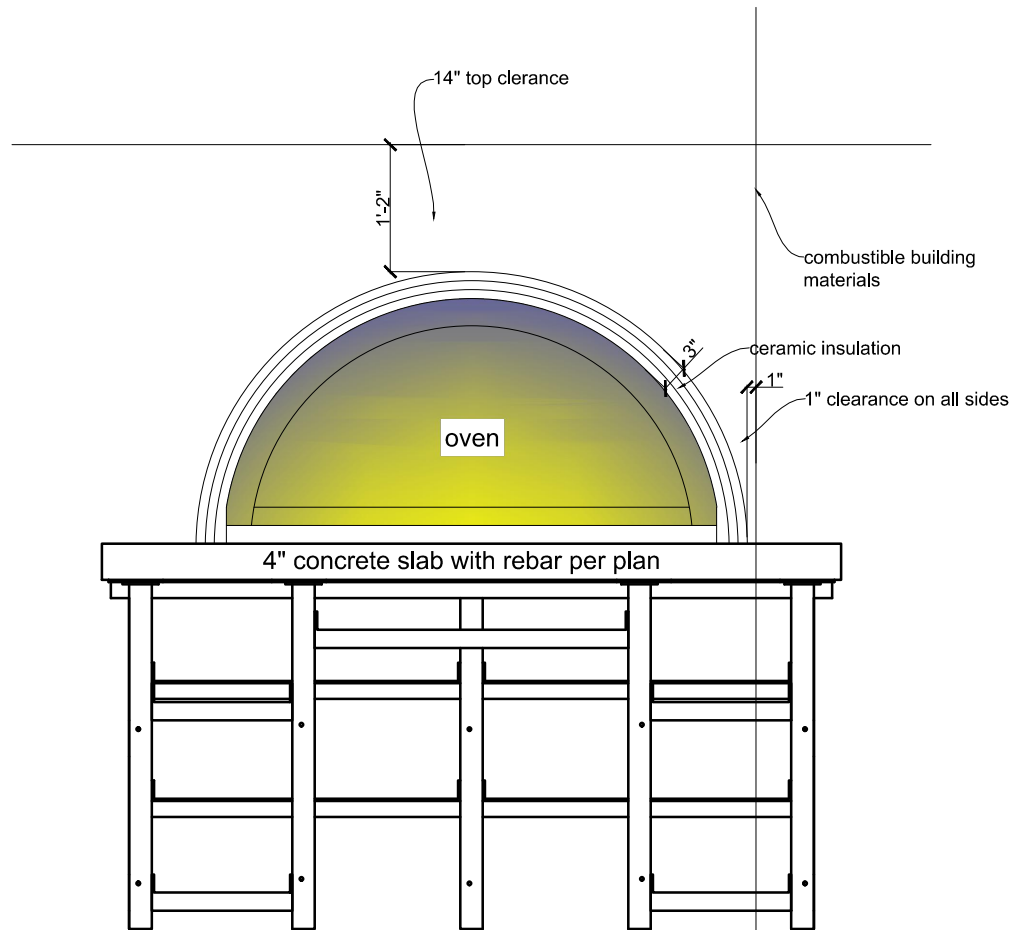

VERONA 560 installation

www.californo.co | 855.55.forno (36766) | info@californo.co
209 NW 4th Ave. Hallandale Beach, Florida 33309

© 2016 V 1.8

CALIFORNO

THE BETTER PIZZA OVEN

VERONA SERIES

V-560

Modular Refractory Pizza Oven Kit | Professional COMMERCIAL Wood Fired Oven | Made in USA Since 2005

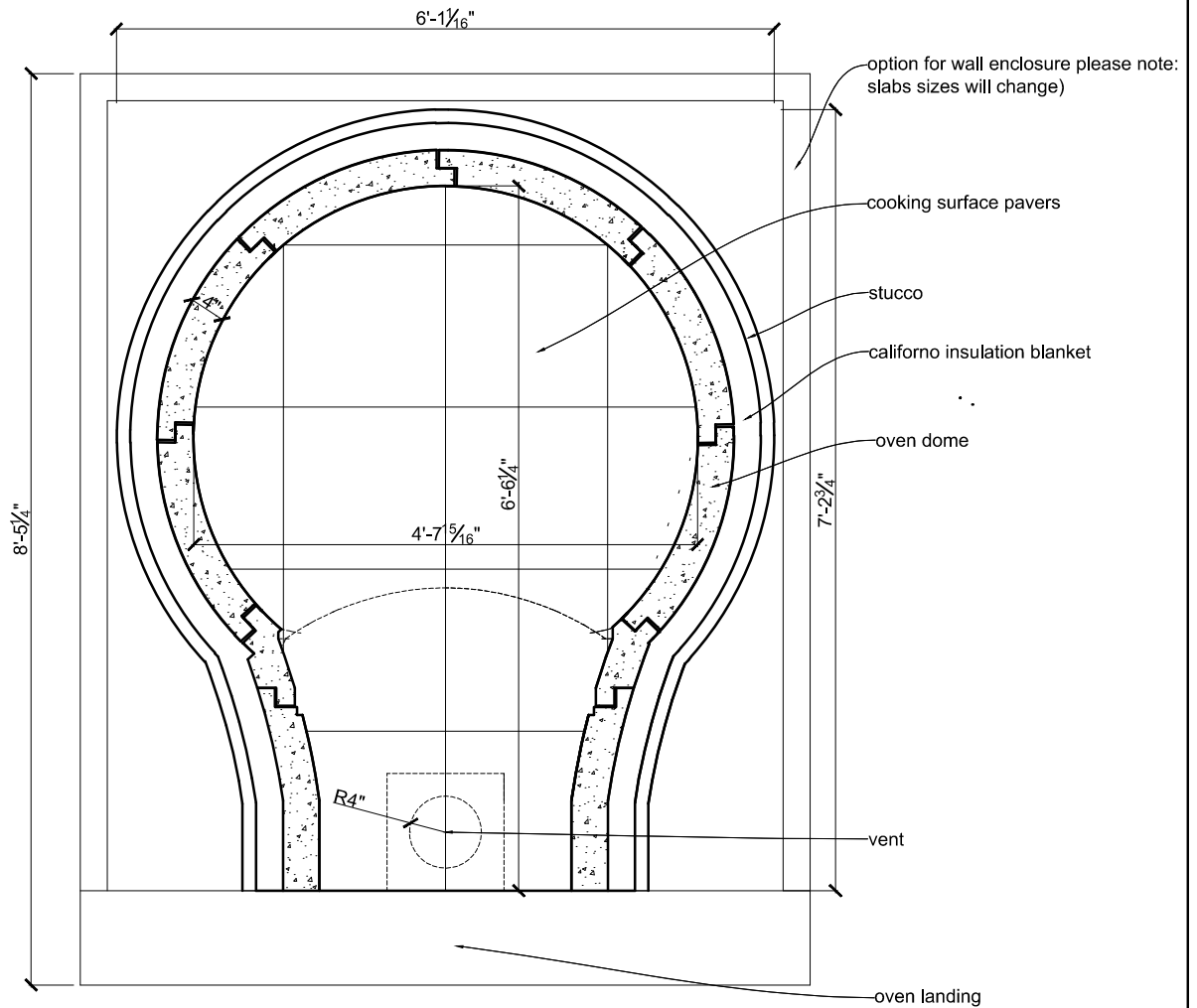

VERONA 560 installation

www.californo.co | 855.55.forno (36766) | info@californo.co
209 NW 4th Ave. Hallandale Beach, Florida 33309

© 2016 V 1.8

CALIFORNO

THE BETTER PIZZA OVEN

VERONA SERIES

V-560

Modular Refractory Pizza Oven Kit | Professional COMMERCIAL Wood Fired Oven | Made in USA Since 2005

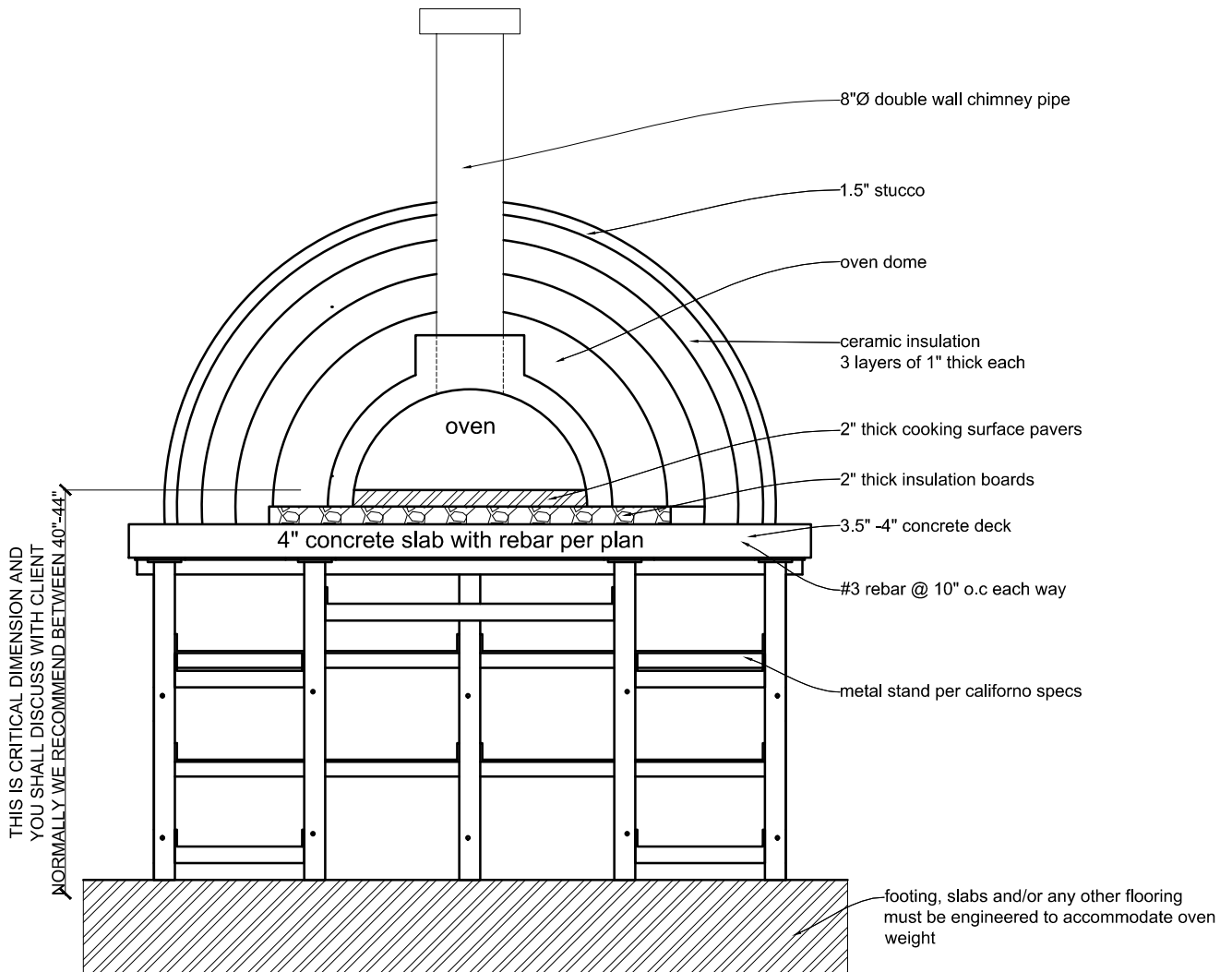

VERONA 560 installation

www.californo.co | 855.55.forno (36766) | info@californo.co
209 NW 4th Ave. Hallandale Beach, Florida 33309

© 2016 V 1.8

CALIFORNO

THE BETTER PIZZA OVEN

VERONA SERIES

V-560

Modular Refractory Pizza Oven Kit | Professional COMMERCIAL Wood Fired Oven | Made in USA Since 2005

STEP 1: POURING YOUR SLAB ON GRADE

CHOOSE INSTALLATION AREA AND POUR THE LOWER CONCRETE SLAB ON GRADE. PLEASE NOTE, SIZE OF SLAB ON GRADE IS DEPEND ON YOUR CLIENT DESIGN. CALIFORNO RECOMMEND A MINIMUM SLAB OF 6'-1" WIDE X 8'-5" FOR VERONA 560 MODEL AND IT IS VARY FROM MODEL TO MODEL AND FROM ONE TYPE OF INSTALLATION TO ANOTHER.

SO... PLEASE MAKE SOME SKETCHES AND DO SOME DRY FIT AND KEEP THIS FORMULA BELOW IN MIND:

SLAB WIDTH: RIGHT TO LEFT:
OVEN DOME EXTERIOR SIZE + ((OVEN INSULATION + OVEN FINISH (STUCCO OR WALLS))X2 = OVEN SLAB WIDTH! AT A MINIMUM.

SLAB DEPTH: FRONT TO BACK:
OVEN DOME EXTERIOR SIZE + ((OVEN INSULATION + OVEN FINISH (STUCCO OR WALLS))X1 = OVEN SLAB WIDTH! AT A MINIMUM.

IN CASE YOUR INSTALLATION IS NOT ON CONCRETE SLAB PLEASE CONSULT WITH ENGINEER AND CHECK LOCAL CODES ON RE INFORCING YOUR WOODEN FLOOR.

VERONA 560 installation

www.californo.co | 855.55.forno (36766) | info@californo.co
209 NW 4th Ave. Hallandale Beach, Florida 33309

© 2016 V 1.8

CALIFORNO

THE BETTER PIZZA OVEN

VERONA SERIES

V-560

Modular Refractory Pizza Oven Kit | Professional COMMERCIAL Wood Fired Oven | Made in USA Since 2005

STEP 2: ASSEMBLING YOUR METAL FRAME

AFTER YOUR SLAB ON GRADE IS DRY,
START ASSEMBLING YOUR METAL BASE,
USING THE BOLTS INCLUDED IN THE KIT.

*** REMEMBER TO LEAVE THE WOOD
STORAGE OPENING IN THE FRONT
WALL.

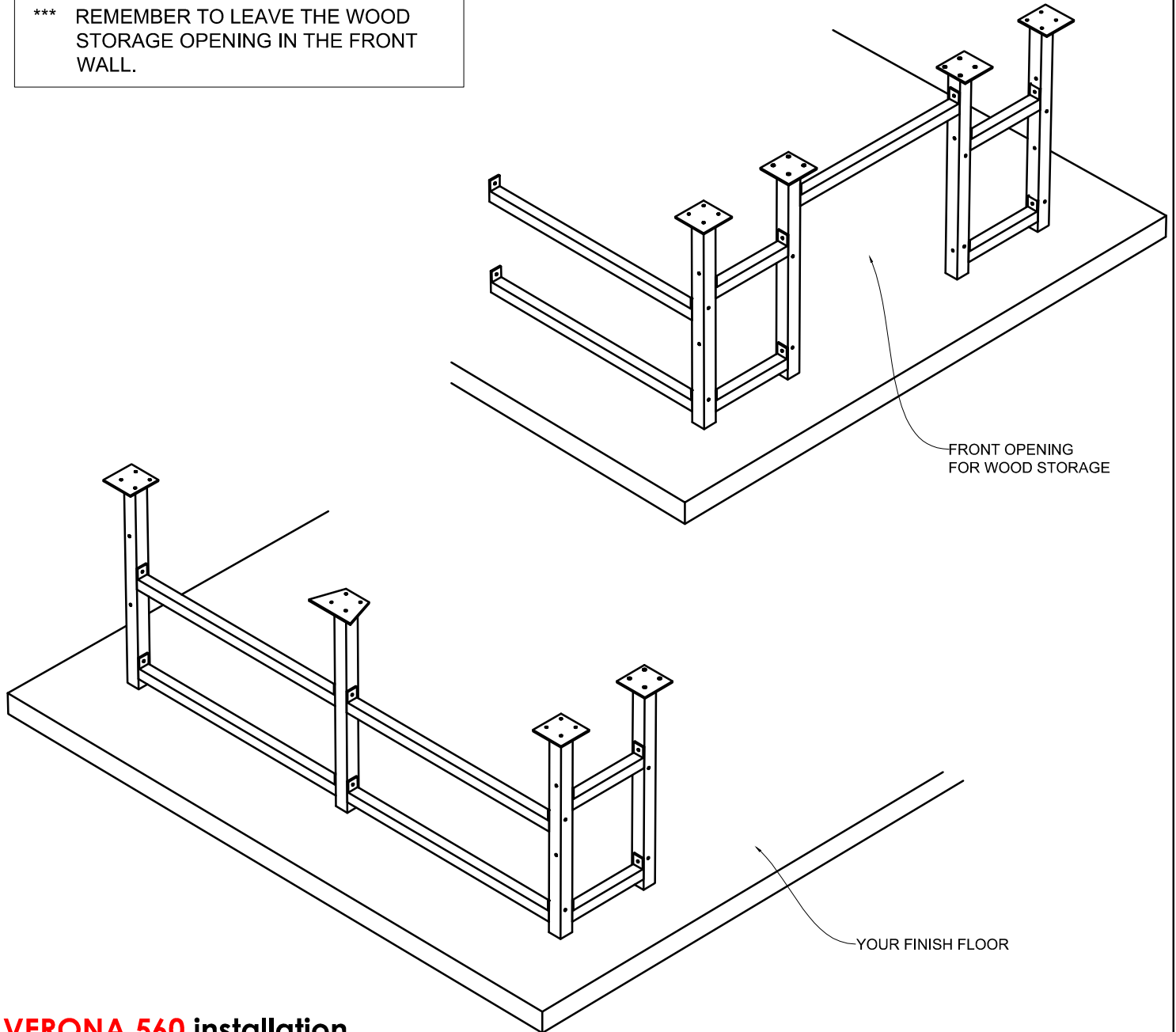

VERONA 560 installation

www.californo.co | 855.55.forno (36766) | info@californo.co
209 NW 4th Ave. Hallandale Beach, Florida 33309

© 2016 V 1.8

CALIFORNO

THE BETTER PIZZA OVEN

VERONA SERIES

V-560

Modular Refractory Pizza Oven Kit | Professional COMMERCIAL Wood Fired Oven | Made in USA Since 2005

STEP 2: ASSEMBLING YOUR METAL FRAME

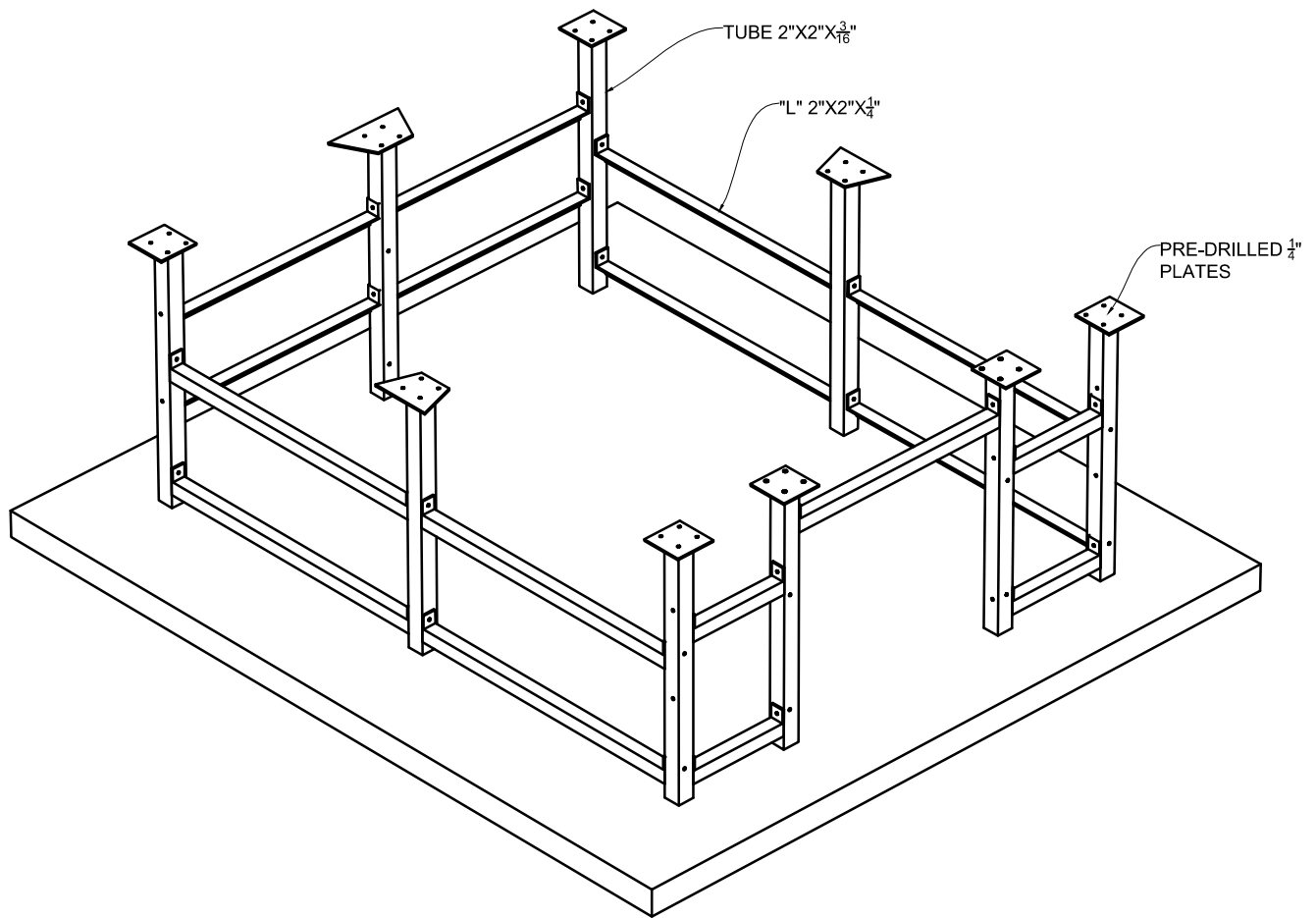

VERONA 520 installation

www.californo.co | 855.55.forno (36766) | info@californo.co
209 NW 4th Ave. Hallandale Beach, Florida 33309

© 2016 V 1.8

CALIFORNO

THE BETTER PIZZA OVEN

VERONA SERIES

V-560

Modular Refractory Pizza Oven Kit | Professional COMMERCIAL Wood Fired Oven | Made in USA Since 2005

STEP 2: ASSEMBLING YOUR METAL FRAME

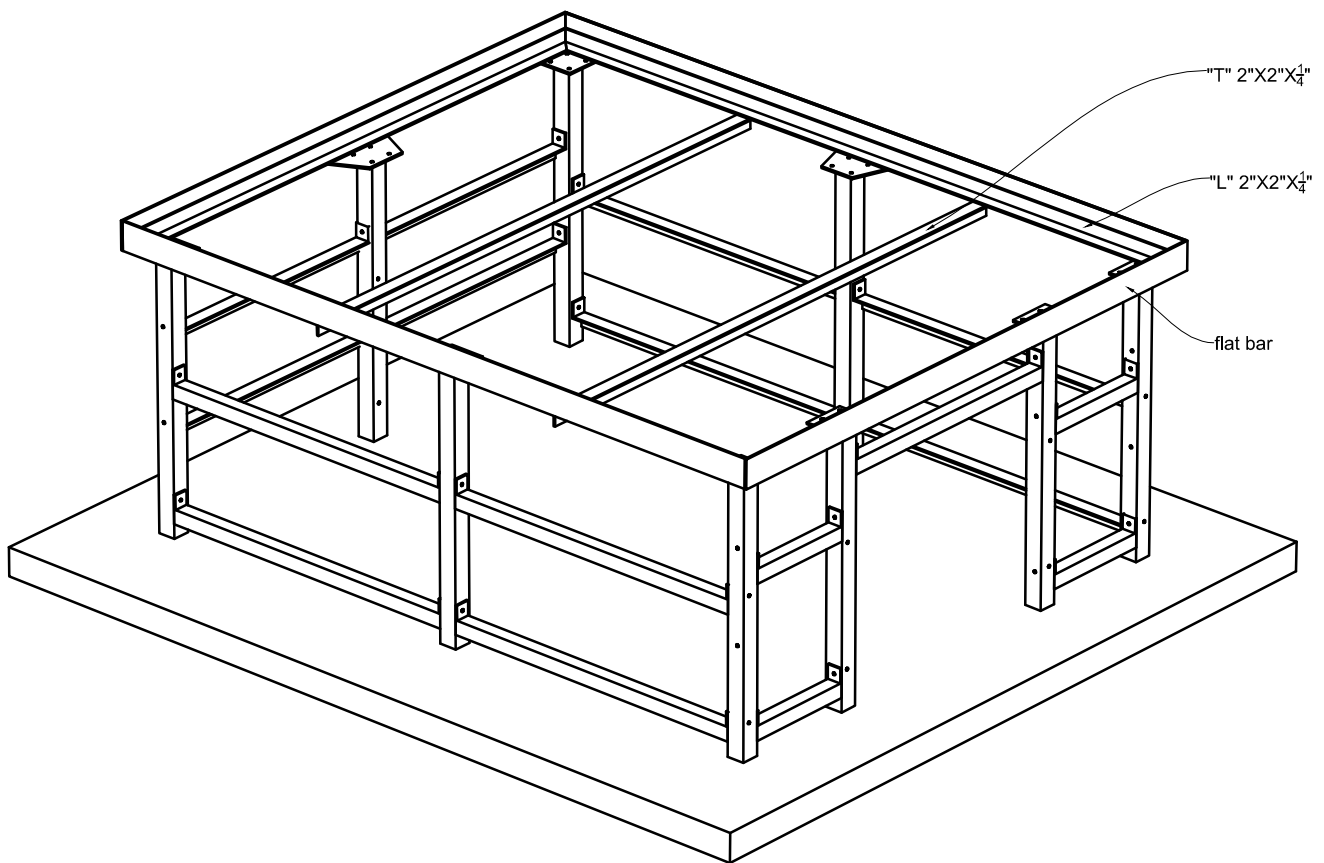

TIGHTEN ALL BOLTS

VERONA 560 installation

www.californo.co | 855.55.forno (36766) | info@californo.co
209 NW 4th Ave. Hallandale Beach, Florida 33309

© 2016 V 1.8

CALIFORNO

THE BETTER PIZZA OVEN

VERONA SERIES

V-560

Modular Refractory Pizza Oven Kit | Professional COMMERCIAL Wood Fired Oven | Made in USA Since 2005

STEP 3: POURING YOUR UPPER SLAB

IN CASE YOU ARE GOING TO USE THE GAS OPTION, THIS IS THE TIME TO MARK AND DRILL THE HOLE FOR THE GAS BURNER PER THE GAS ASSEMBLY INSTRUCTIONS.

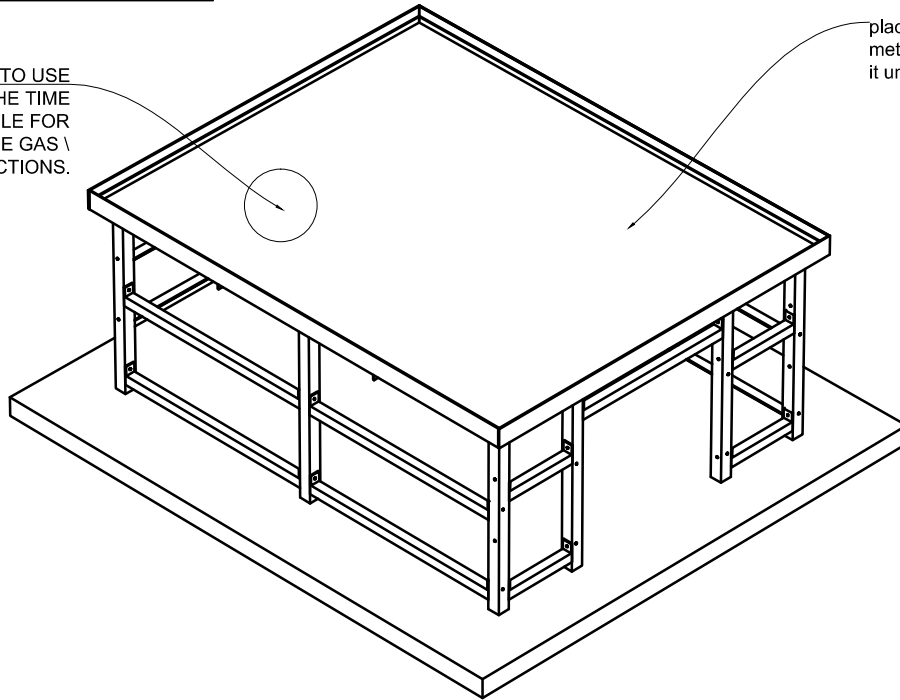

place your $\frac{1}{2}$ " cement board inside the metal frame and support and brace it under it with 2" x 4" lumber

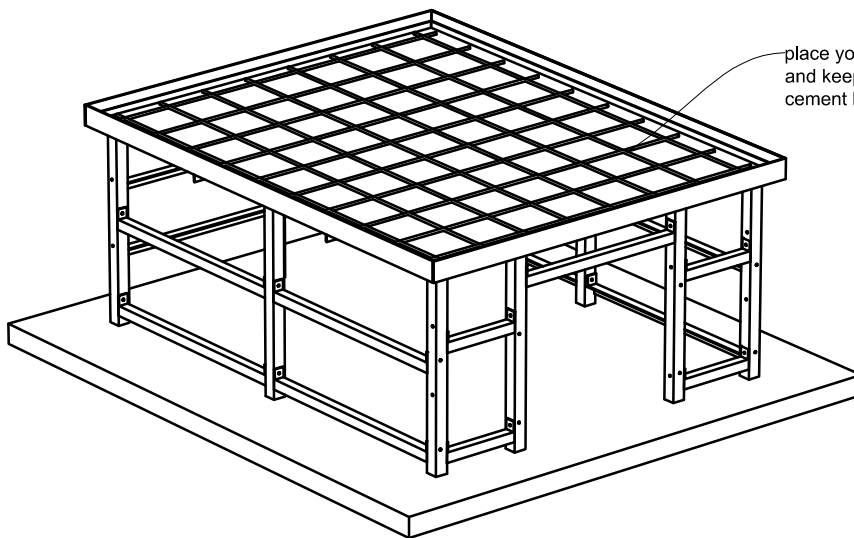

place your rebar and lift it up and keep it away from the cement board

VERONA 560 installation

www.californo.co | 855.55.forno (36766) | info@californo.co
209 NW 4th Ave. Hallandale Beach, Florida 33309

© 2016 V 1.8

CALIFORNO

THE BETTER PIZZA OVEN

VERONA SERIES

V-560

Modular Refractory Pizza Oven Kit | Professional COMMERCIAL Wood Fired Oven | Made in USA Since 2005

STEP 3: POURING YOUR UPPER SLAB

NOW IT'S THE TIME TO FORM AND POUR THE UPPER SLAB ABOVE THE METAL FRAME YOU ASSEMBLED IN PREVIOUS STEP.

*** YOU WILL NEED SOME 2"X4" AS VERTICAL SUPPORT FOR THE CEMENT BOARD THAT YOU WILL PLACE AS A BOTTOM SUPPORT FOR THE PROPOSED UPPER SLAB.

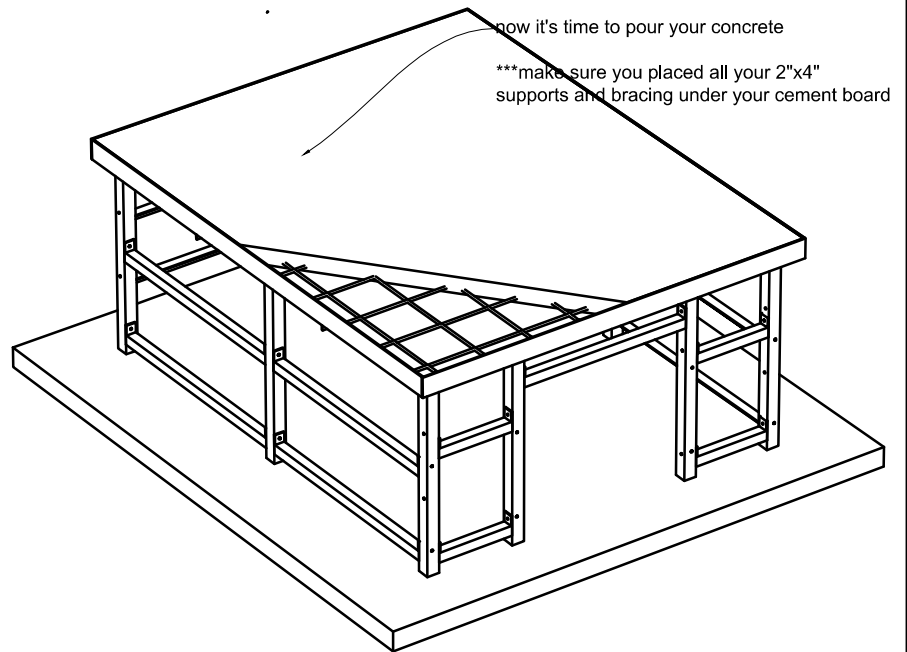

STEP 4: PLACING THE UNDERCOOKING INSULATION BOARDS

NOW YOU WILL CUT TO THE SHAPE THE CALIFORNO INSULATION BOARD AND PLACE IT TO THE UPPER SLAB.

*** EXACT LOCATION OF THE INSULATION BOARD IS CRITIC AND BEING DETERMINED BY YOUR PROPOSED POSITIONING OF THE OVEN OVER THE UPPER SLAB!

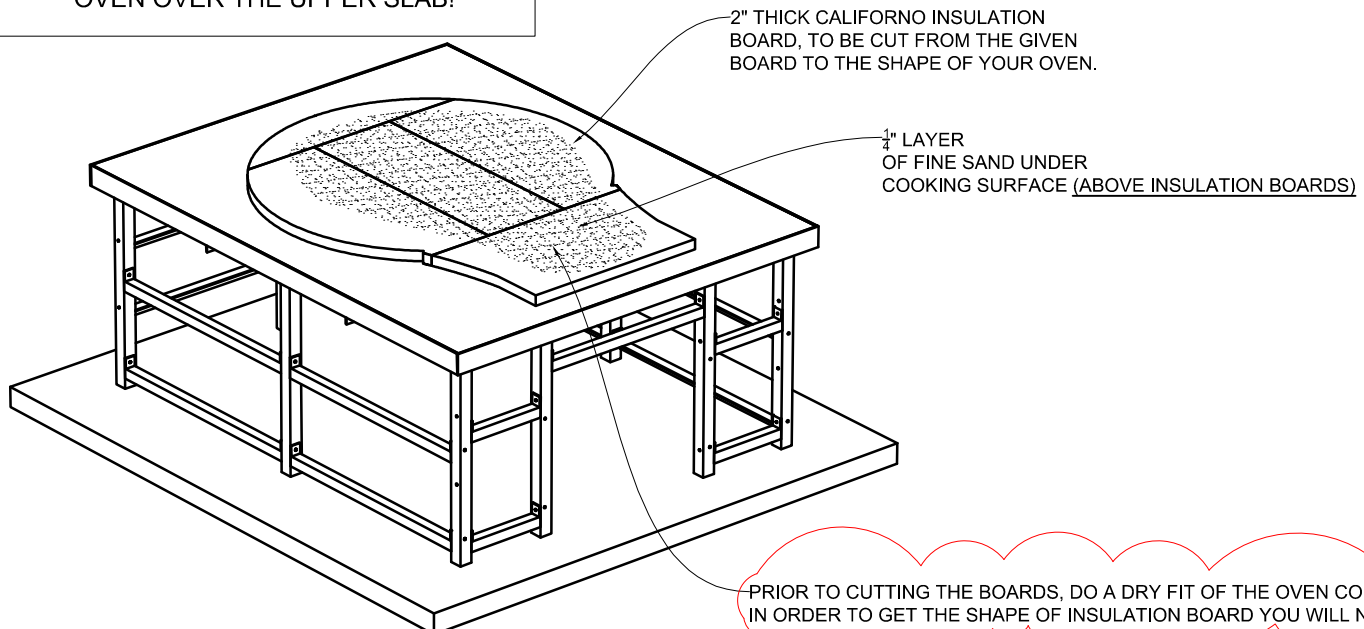

VERONA 560 installation

www.californo.co | 855.55.forno (36766) | info@californo.co
209 NW 4th Ave. Hallandale Beach, Florida 33309

© 2016 V 1.8

CALIFORNO

THE BETTER PIZZA OVEN

VERONA SERIES

V-560

Modular Refractory Pizza Oven Kit | Professional COMMERCIAL Wood Fired Oven | Made in USA Since 2005

COOKING SURFACE ASSEMBLY

- *** Spread a 1/4" (6 mm) layer of fine sand or high temperature refractory mortar using a notched trowel OVER THE INSULATION BOARDS.
- *** Lay your cooking surface in place, butting the joints tightly together. Check for level. This is your true cooking surface, so it is vital that it is completely level in all directions.
- *** Check again that the oven "faces" straight forward.
- *** IMPORTANT: do not fill in side walls between floor and inner dome with mortar. Gap is by design to allow for thermal expansion and contraction during oven use.

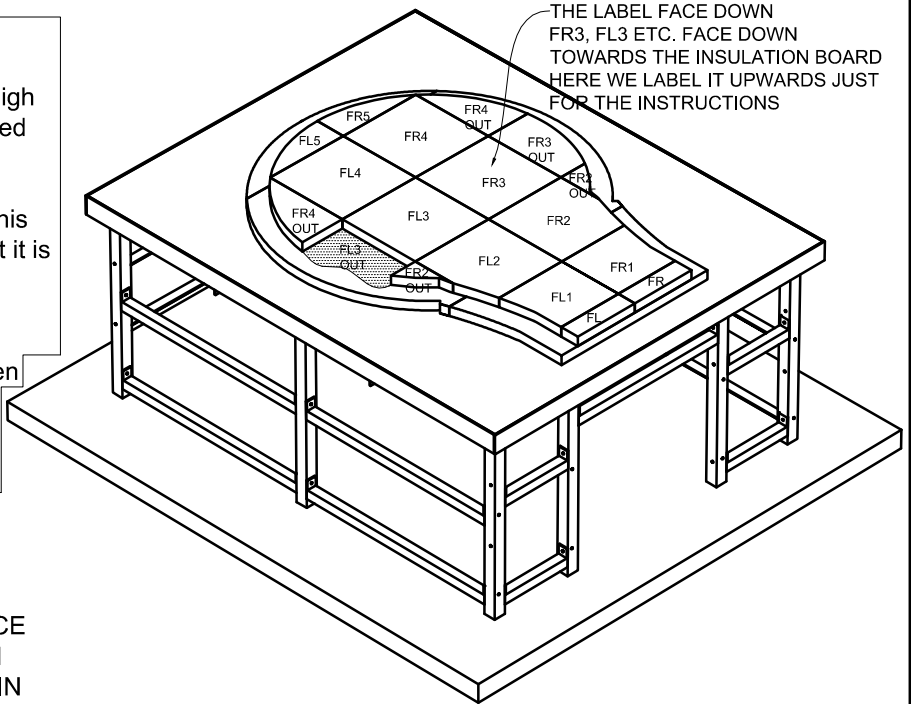

NOTE:

EACH ONE OF YOUR COOKING SURFACE PIECE IS UNIQUE AS YOU ARE AND IT'S LABELED ON THE BACK OF YOUR PIECES AND AS SHOWN IN DIAGRAM ABOVE:
1R, 2R, 3R, RIGHT REAR
1L, 2L, 3L, LEFT

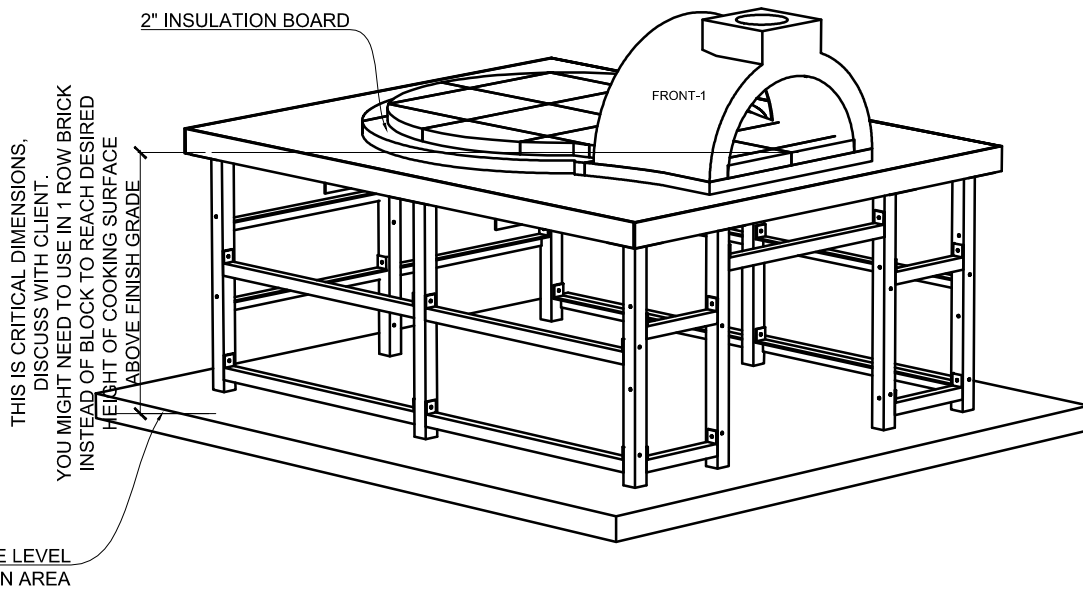

VERONA 560 installation

www.californo.co | 855.55.forno (36766) | info@californo.co
209 NW 4th Ave. Hallandale Beach, Florida 33309

© 2016 V 1.8

CALIFORNO

THE BETTER PIZZA OVEN

VERONA SERIES

V-560

Modular Refractory Pizza Oven Kit | Professional COMMERCIAL Wood Fired Oven | Made in USA Since 2005

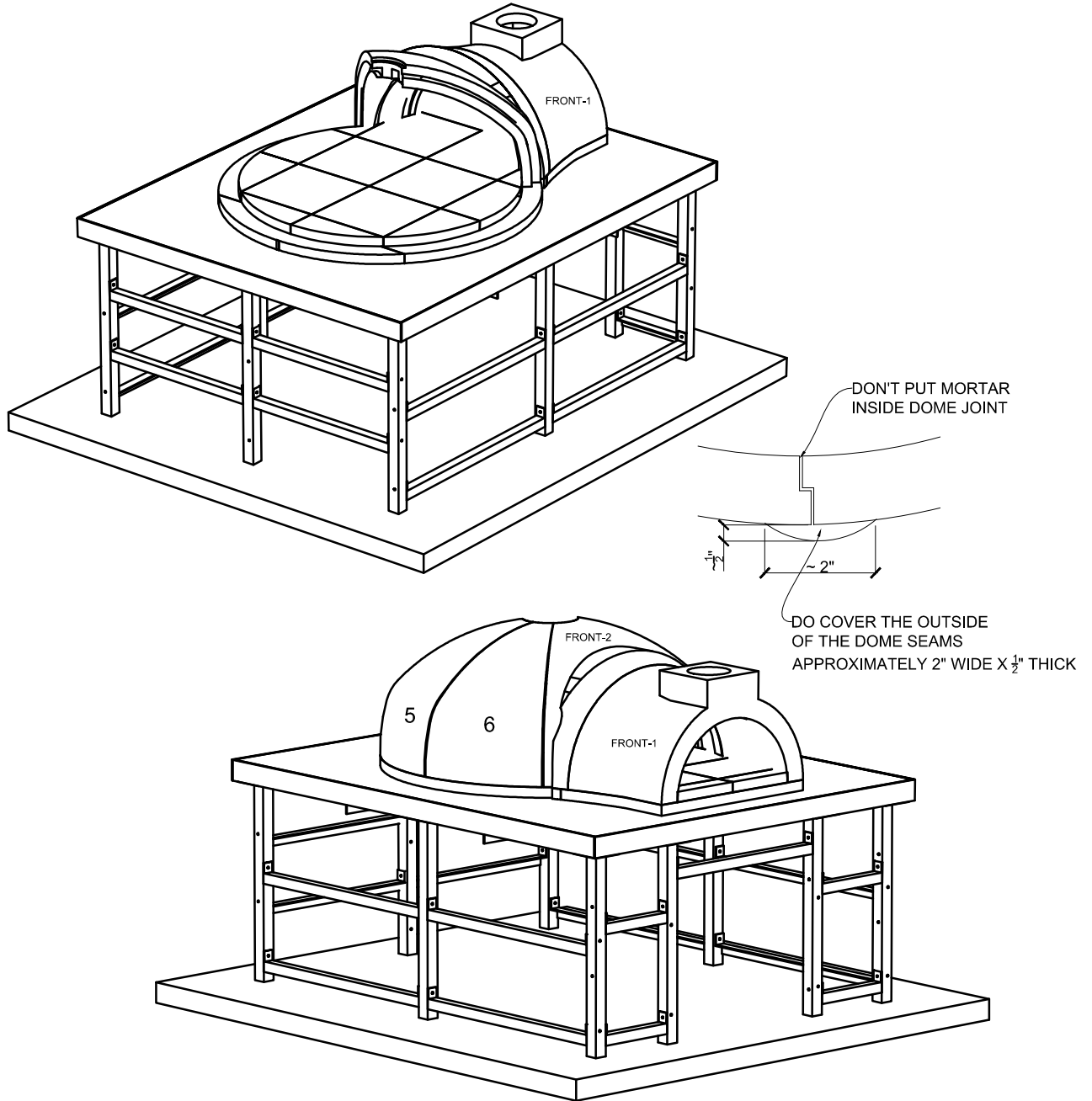

VERONA 560 installation

www.californo.co | 855.55.forno (36766) | info@californo.co
209 NW 4th Ave. Hallandale Beach, Florida 33309

© 2016 V 1.8

CALIFORNO

THE BETTER PIZZA OVEN

VERONA SERIES

V-560

Modular Refractory Pizza Oven Kit | Professional COMMERCIAL Wood Fired Oven | Made in USA Since 2005

ONLY PLACE MORTAR ON THE OUTSIDE OF THE DOME, BUT NOT ON THE INSIDE JOINTS

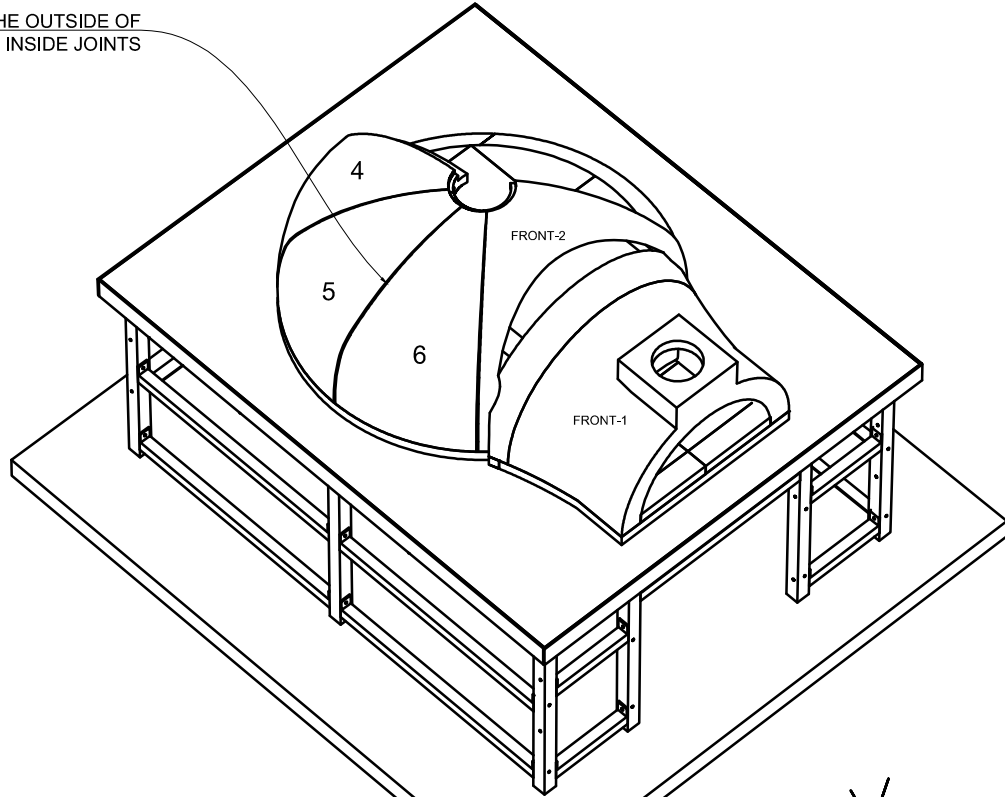

~~X~~ DON'T PLACE MORTAR INSIDE THE DOME JOINTS

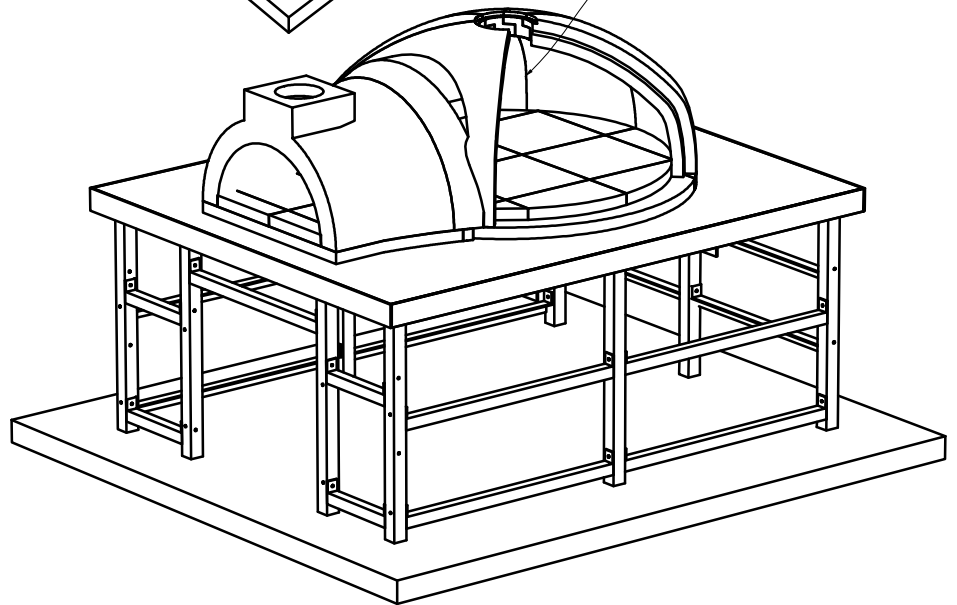

VERONA 560 installation

www.californo.co | 855.55.forno (36766) | info@californo.co
209 NW 4th Ave. Hallandale Beach, Florida 33309

© 2016 V 1.8

CALIFORNO

THE BETTER PIZZA OVEN

VERONA SERIES

V-560

Modular Refractory Pizza Oven Kit | Professional COMMERCIAL Wood Fired Oven | Made in USA Since 2005

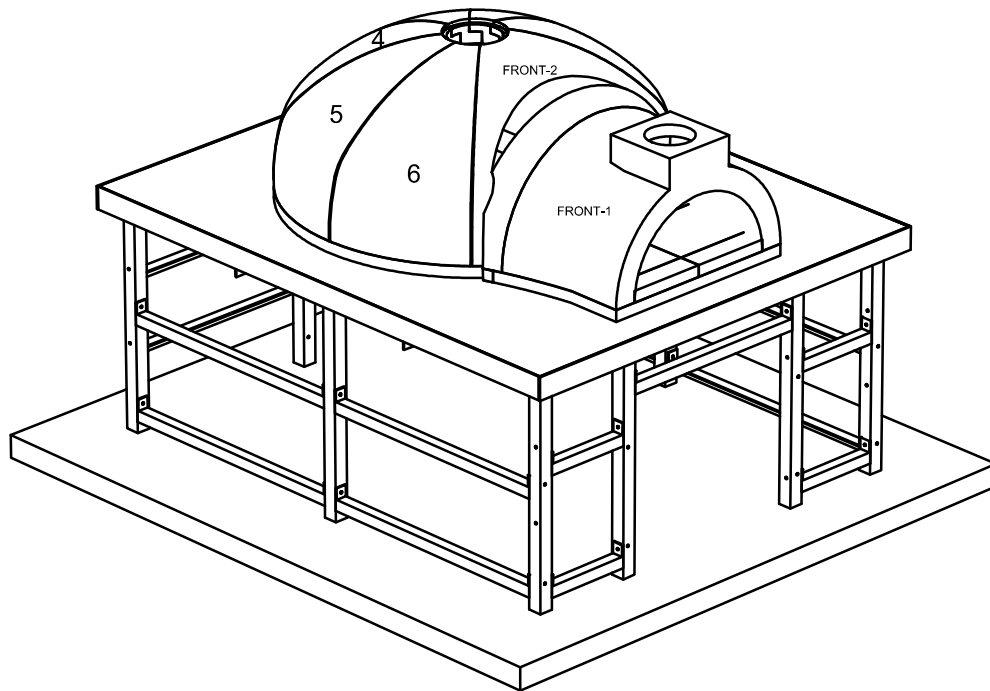
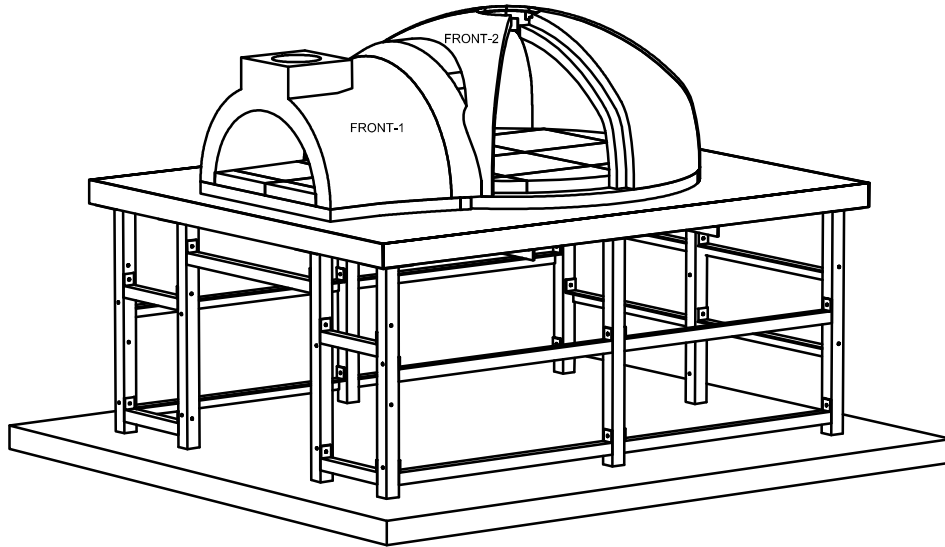

VERONA 560 installation

www.californo.co | 855.55.forno (36766) | info@californo.co
209 NW 4th Ave. Hallandale Beach, Florida 33309

© 2016 V 1.8

CALIFORNO

THE BETTER PIZZA OVEN

VERONA SERIES

V-560

Modular Refractory Pizza Oven Kit | Professional COMMERCIAL Wood Fired Oven | Made in USA Since 2005

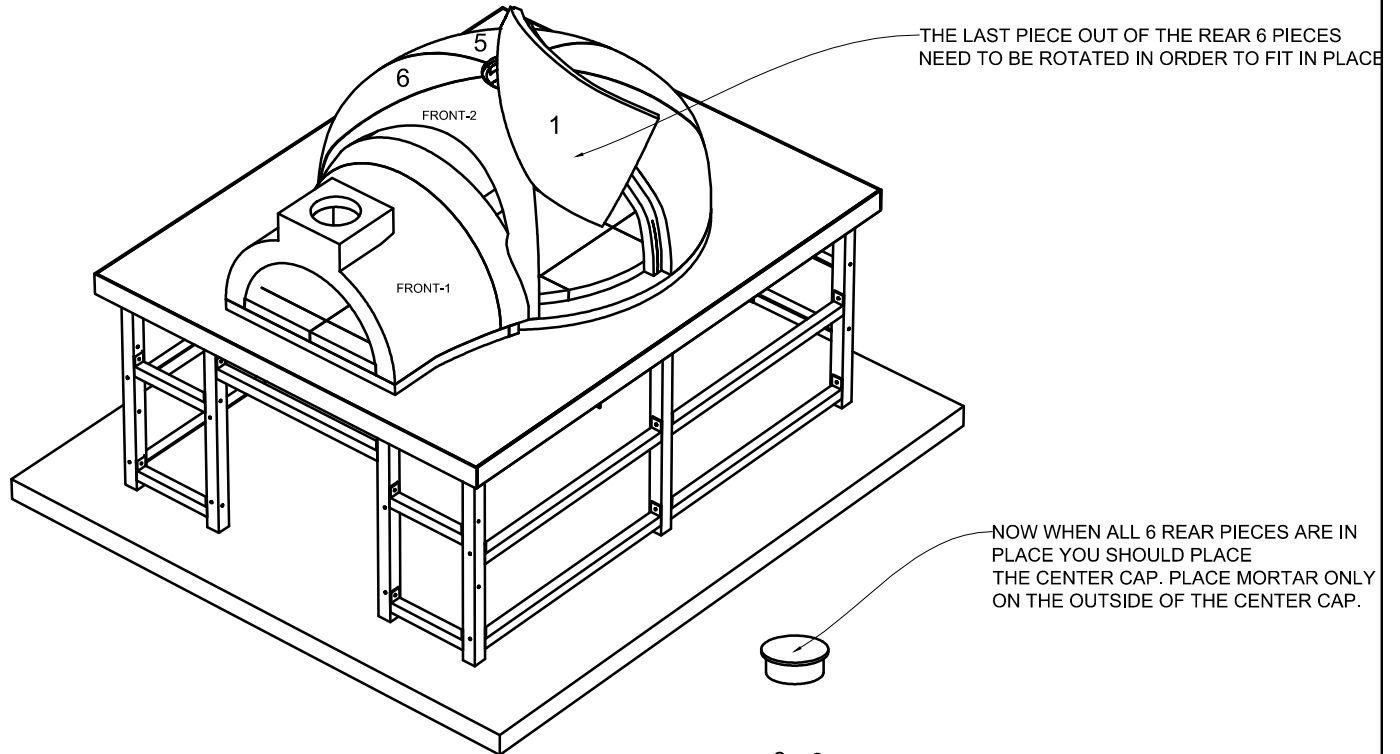

IT'S NOW TIME TO PLACE THE REMOTE THERMOMETER

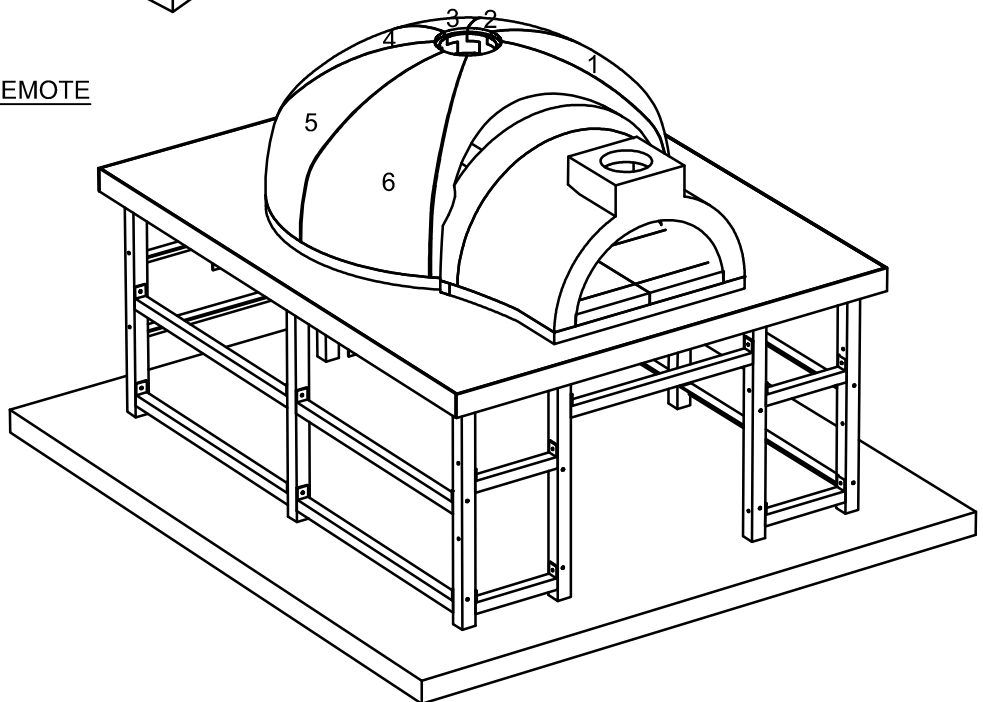

VERONA 560 installation

www.californo.co | 855.55.forno (36766) | info@californo.co
209 NW 4th Ave. Hallandale Beach, Florida 33309

© 2016 V 1.8

CALIFORNO

THE BETTER PIZZA OVEN

VERONA SERIES

V-560

Modular Refractory Pizza Oven Kit | Professional COMMERCIAL Wood Fired Oven | Made in USA Since 2005

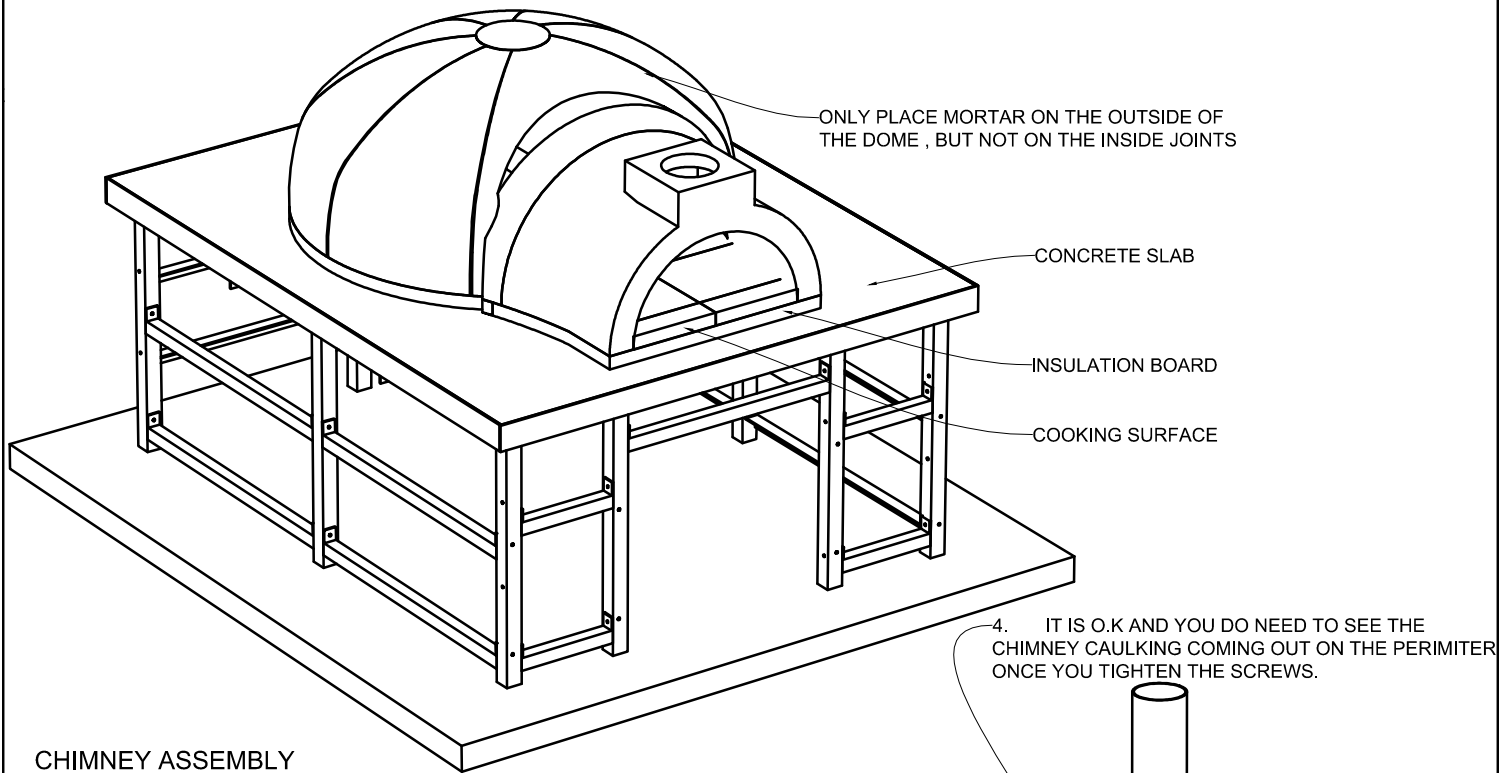

CHIMNEY ASSEMBLY

- *** USE YOUR CHIMNEY ANCHOR PLATE TO MARK THE HOLES FOR DRILLING ABOVE OVEN CHIMNEY MANIFOLD.
- *** DRILL YOUR HOLES AND THEN COAT THE BOTTOM OF THE CHIMNEY WITH FIREPLACE CAULKING AND SCREW ON THE CHIMNEY TO THE MANIFOLD USING TAPCON CONCRETE ANCHORS.
- *** SEAL THE CHIMNEY AND VENT WITH ADDITIONAL FIREPLACE CAULK.

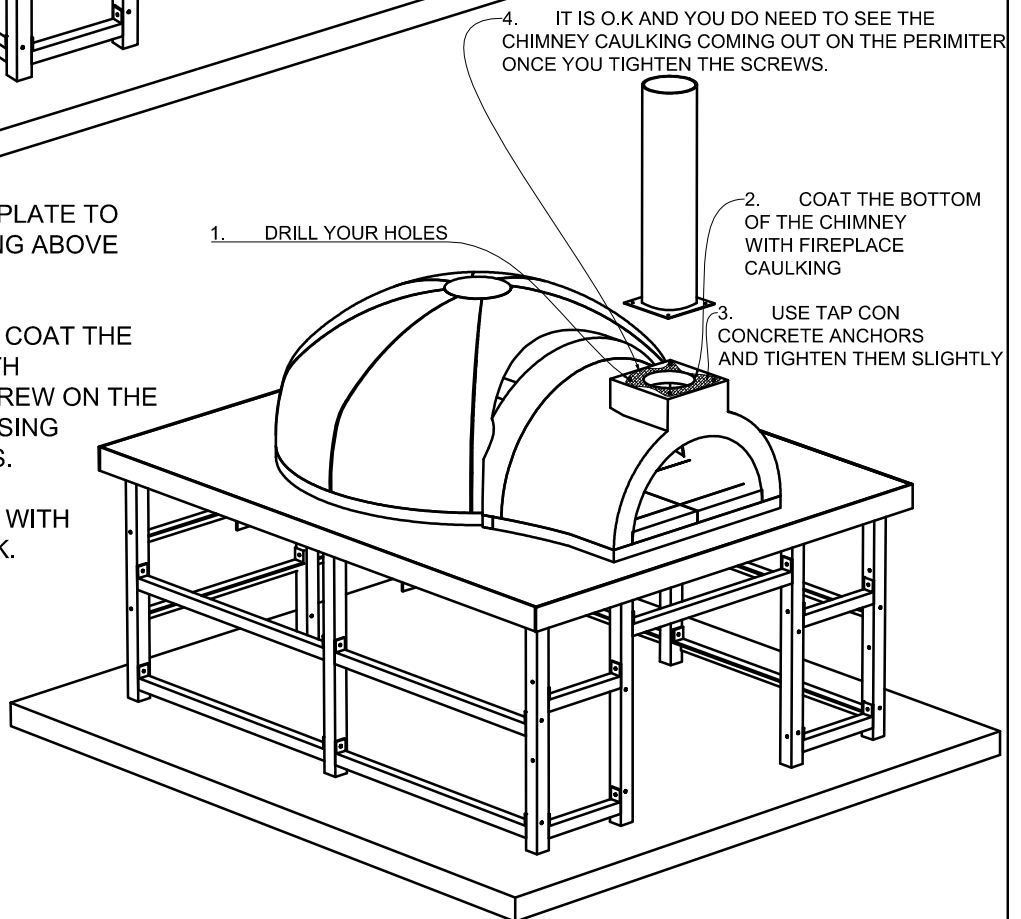

VERONA 560 installation

www.californo.co | 855.55.forno (36766) | info@californo.co
209 NW 4th Ave. Hallandale Beach, Florida 33309

© 2016 V 1.8

CALIFORNO

THE BETTER PIZZA OVEN

VERONA SERIES

V-560

Modular Refractory Pizza Oven Kit | Professional COMMERCIAL Wood Fired Oven | Made in USA Since 2005

DOME INSULATION

- *** APPLY YOUR 3 LAYER DOME INSULATION
- *** AND KEEP IN MIND THAT THAT WAY YOU
- *** SHAPE IT WILL DETERMINE YOUR FINAL
- *** OUTSIDE SHAPE OF YOUR OVEN

THE STUCCO LAYERS THAT WILL COME LATER
WILL JUST DO FINAL TUNNING OF YOUR OVEN
SHAPE BUT REAL SHAPE IS TO BE "SCULPTURE"
BY THE INSULATION BLANKET

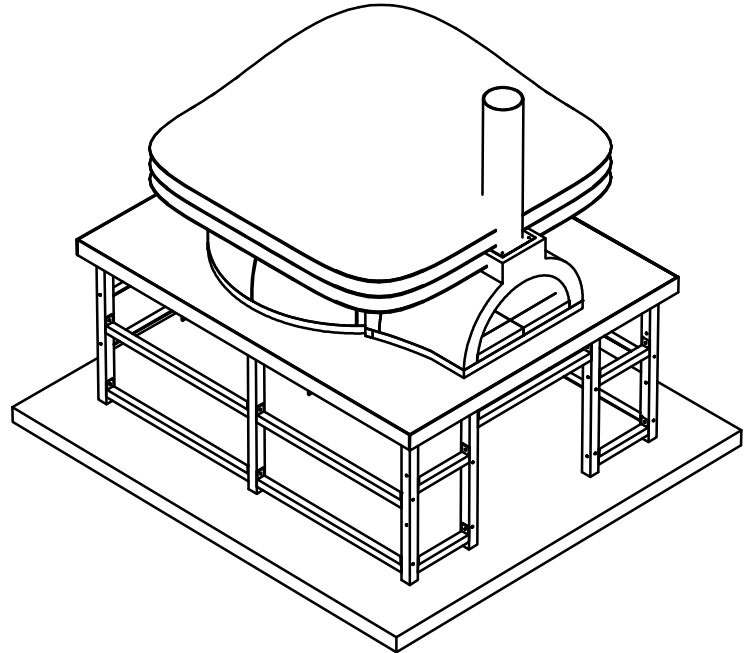

YOU MUST MAKE SURE THAT 2ND LAYER
MATERIAL IS OVERLAPPING THE SEAM OF 1ST
LAYER AND 3RD LAYER INSULATION IS
OVERLAPPING THE SEAMS OF 2ND LAYER

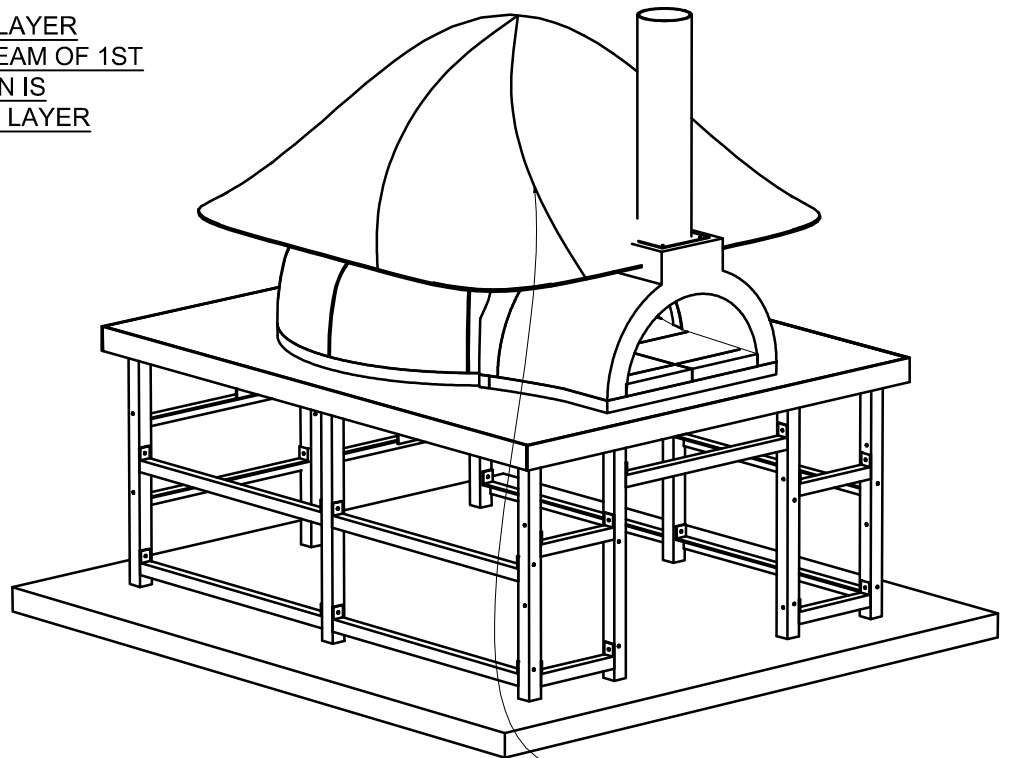

OVERLAP SEAM OF PREVIOUS LAYER OF
INSULATION MATERIAL

VERONA 560 installation

www.californo.co | 855.55.forno (36766) | info@californo.co
209 NW 4th Ave. Hallandale Beach, Florida 33309

© 2016 V 1.8

CALIFORNO

THE BETTER PIZZA OVEN

VERONA SERIES

V-560

Modular Refractory Pizza Oven Kit

| Professional COMMERCIAL Wood Fired Oven

| Made in USA Since 2005

THE SHAPE YOU WRAP THE INSULATION ROLLS AROUND YOUR OVEN IS THE FINAL SHAPE OF THE EXTERIOR OF YOUR OVEN

ONCE YOU DONE PLACING YOUR 3 LAYERS OF INSULATION BLANKET, IT IS NOW TIME TO PLACE YOUR LATH.

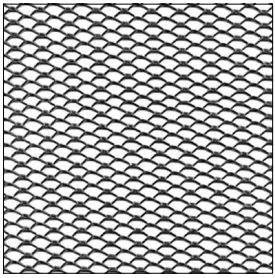

DOME INSULATION

*** WRAP THE OVEN DOME WITH 3 LAYERS OF 1" CALIFORNO INSULATION BLANKET.

OVERLAP ALL JOINTS

SHAPE YOUR OVEN DOME WITH WIRE LATHE AND COVER IT WITH 2 COAT STUCCO SYSTEM.

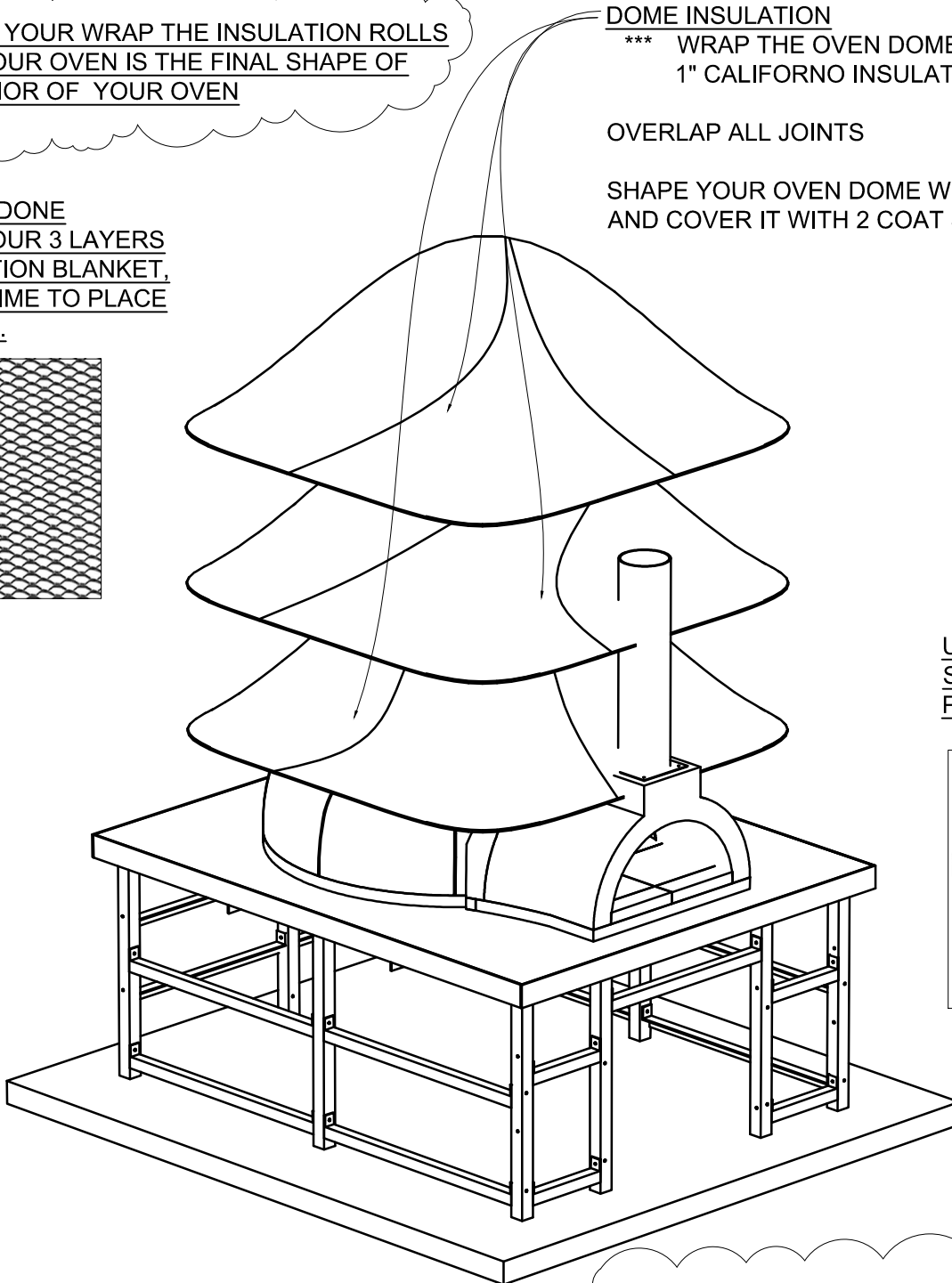

USE SOME TIE WIRE TO SECURE YOUR LATH IN PLACE



THE SHAPE YOU WRAP THE INSULATION ROLLS AROUND YOUR OVEN IS THE FINAL SHAPE OF THE EXTERIOR OF YOUR OVEN

VERONA 560 installation

www.californo.co | 855.55.forno (36766) | info@californo.co
209 NW 4th Ave. Hallandale Beach, Florida 33309

CALIFORNO

THE BETTER PIZZA OVEN

VERONA SERIES

V-560

Modular Refractory Pizza Oven Kit

Professional COMMERCIAL Wood Fired Oven

Made in USA Since 2005

FINAL STEP: APPLYING THE STUCCO

AFTER YOU DONE APPLYING THE LATH IN PREVIOUS STAGE, IT'S NOW TIME TO APPLY YOUR STUCCO LAYERS.

1ST LAYERS, WILL REALLY DETERMINED YOUR FINAL OVEN SHAPE

2ND LAYER WILL SMOOTHEN AND FIX IMPERFECTIONS

3RD LAYERS IS YOUR COLOR LAYER

OR YOU CAN APPLY MOSAIC OVER THE 2ND LAYER OR ENCLOSE YOUR OVEN WITH METAL FACADE

ONCE THE 2ND LAYER OF THE STUCCO CURED AND ACCORDING TO THE STUCCO MANUFACTURER INSTRUCTIONS, ITS NOW TIME TO APPLY THE 3RD (COLOR COAT)

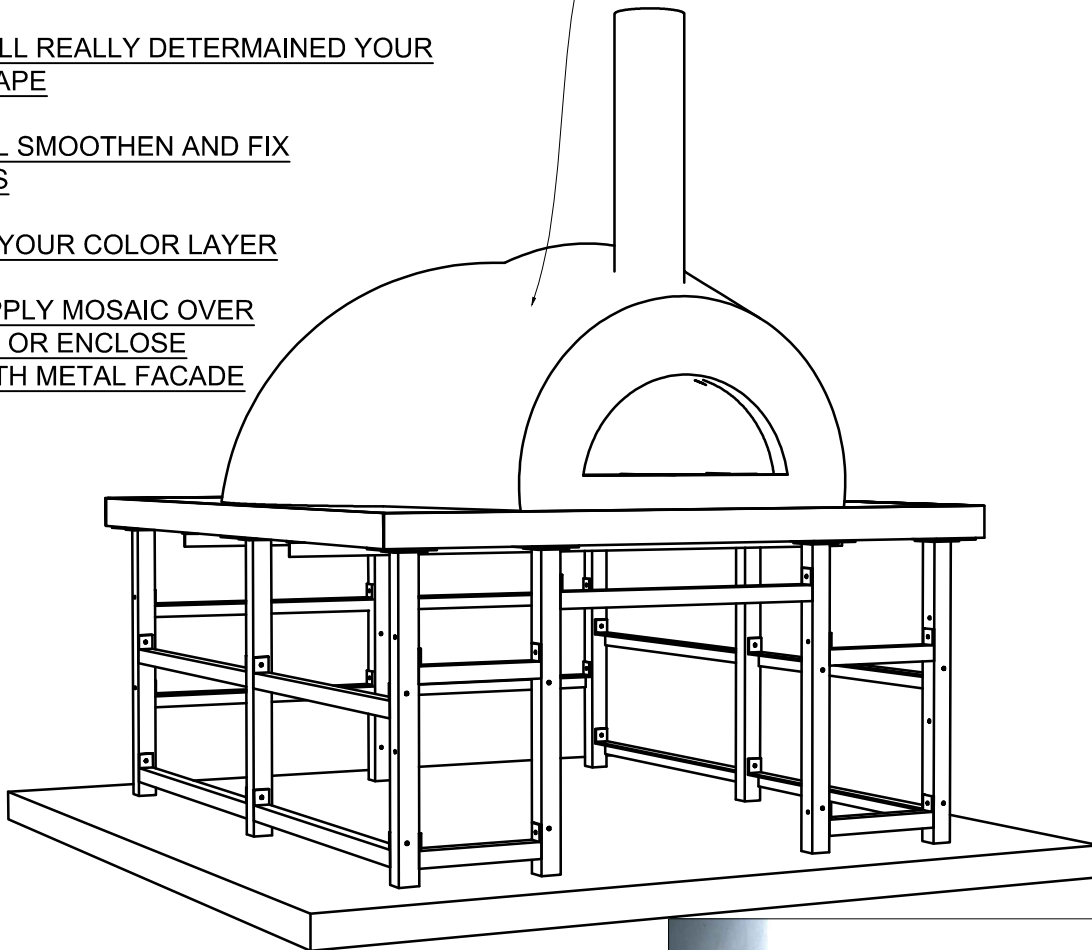

VERONA 560 installation

www.californo.co | 855.55.forno (36766) | info@californo.co
209 NW 4th Ave. Hallandale Beach, Florida 33309

© 2016 V 1.8

CALIFORNO

THE BETTER PIZZA OVEN

Curing Your Oven Instructions for Curing Your Pizza Oven

Follow these instructions to cure your pizza oven. Curing your oven is critical to your pizza oven's performance. **Failure to follow these instructions can result in damage up to and including cracking the dome**, severely impacting heat retention.

NOTE: For ovens with Gas burner, there are shortcuts to the curing process you can find in the Installation Manual. A Californo technician can be made available through our contact form to help walk you through some tricks to make this easier.

1. Why is proper curing so important?

Like with any concrete items there is always excess water that is evaporating overtime from product to the outside air. In a conventional concrete products it can take up to 360 days to get the very inside of the concrete 100 cure. Curing your oven components will get it to the maximum strength when done properly. However, fast curing will cause the all amount of water to escape simultaneously and may result in cracking the dome. Also, after you've complete your oven installation, there is still a great deal of moisture in the mortars, hearth concrete, vermiculite, and the oven chamber and manifold. Each of these oven components was produced in our facility and got dry by air only. Simply letting the oven stand for a week or month will not cure the moisture out of the oven.

2. Can I cure the oven dome without installing the insulation and decorative facade?

Technically you can, but it is not recommended for a few reasons:

- Without insulation, it can present a fire and safety hazard;
- After curing, your oven will reach higher temperatures than before it was cured. It will reach 1000 deg F, that mean if you cure your oven at first and later do your stucco, there will be water that try to escape the stucco which will crack it.

3. When can I start my curing process?

Before you start the curing process, let the complete oven sit for 5 days. Regardless if it was raining or not during that time rain will help strengthening your oven. If you purchased a fully assembled pizza oven from Californo, you may start the curing process of your oven without waiting the 5 days, as naturally 5 days has passed from the day we completed the assembly until you received the oven so that mean you may start the curing of your assembled oven the day you received it.

4. How do we cure the oven? *Important Note:*

It is critical for proper curing and avoiding damage that you do not go above these temperatures shown below during the first two days.

It is important that you cure your pizza oven slowly over a 5 day period. You build a series of five increasingly larger fires, starting with a low temperature (see below). The first-day fire is no more than kindling and thin strips of wood.

Curing Your Oven Instructions for Curing Your Pizza Oven

1st Day: 300° F for 5 hours minimum.

Start and maintain the fire in the center of the dome, not on the perimeter of the oven. **You don't want the fire to get too high and touch the dome.** You should leave the door partly open allowing about 2" gap once the fire is lit that will help direct the smoke up the vent as temperature is relatively low and smoke is than heavier. You should look at the analog temperature gauge if you purchased and installed one. The temperature gauge reads the oven's air temperature. For a more accurate temperature reading of the oven refractory surfaces, which can be use for many types of cooking, you can use the optional Digital Infrared Thermometer, which can be purchased in the Californo Store. You want to measure the temperature at the dome of the oven, not the side wall or floor. This will be the hottest point of the oven. The temperature can vary slightly, but try not to exceed the temperature for that day's cure schedule by more than a few degrees, better to be 20 degrees cooler than hotter. Especially on day one and two.

Close the oven door every evening to preserve dryness and heat.

2nd Day: Repeat process at 350° F (177 Celsius)

3rd Day: Repeat process at 400° F (204 Celsius)

4th Day: Repeat process at 450° F (232 Celsius)

5th Day: Repeat process at 500° F (260 Celsius)

Important Notes:

- Use solid wood fuels only.
- DO NOT use charcoal, pressure treated lumber, chipped wood products, sappy wood such as pine, laminated wood or any material other than dry medium or hard firewood.
- DO NOT USE liquid fuel (firelighter fluid, gasoline, lantern oil, kerosene or similar liquids) to start or maintain a fire.
- You can start the fire with an acetylene torch if you have one handy.
- Food grade fire starters are considered acceptable aids when starting a fire.
- Do not use products not specified for use with this oven.
- Never use water to lower the temperature inside the oven, or to extinguish the fire. This will increase wear and tear on your oven and can lead to spalling, pitting and cracking your cooking surface.
- There must be a period of time between completing the masonry work and beginning the actual firing cure.
- Longer is better than shorter, particularly for the actual dome cement.
- The cement and mortar must cure first and this process is actually improved by keeping the cement moist and not letting it dry out. (when installing the dome components, it is a good practice to cover the dome by plastic sheet to avoid the fast escape of humidity in hot climates until you apply the insulation blankets)) Space heaters should not be used to cure an oven. It will produce a high amount of steam in the oven and can become a safety hazard so it is not recommended.