

# 264/269 KIT

## Installation instructions for:

- Buick Century 1982-96
- Buick Electra 1984-94
- Buick Estate Wagon 1984-94
- Buick LeSabre 1984-94
- Buick Park Avenue 1984-94
- Buick Reatta 1990-91
- Buick Regal 1984-87
- Buick Riviera 1983-85
- Buick Riviera 1990-95
- Buick Skyhawk 1982-89
- Buick Skylark 1983-85
- Buick Skylark 1987-95
- Cadillac Deville 1985-93
- Cadillac Eldorado 1984-91
- Cadillac Fleetwood 1985-93
- Cadillac Seville 1984-91
- Chevrolet Blazer (full size) 1989-91
- Chevrolet Celebrity 1982-87
- Chevrolet Citation 1985
- Chevrolet Corvette 1984-89
- Chevrolet Suburban 1989-91
- GMC Jimmy (full size) 1989-91
- GMC Suburban 1989-91
- Oldsmobile Achieva 1992-95
- Oldsmobile Cutlass Calais 1984-91
- Oldsmobile Cutlass Ciera 1982-96
- Oldsmobile Cutlass Supreme 1984-88
- Oldsmobile Delta 88 1986-88
- Oldsmobile Firenza 1982-89
- Oldsmobile 98 1984-90
- Oldsmobile Toronado 1982-85
- Pontiac Bonneville 1982-93
- Pontiac Fiero 1984-88
- Pontiac Grand Am 1985-95
- Pontiac Grand Prix 1985-87

Once the original radio is removed, be sure to **keep the factory brackets**. If the original brackets are lost or missing, follow the guide below. You may need to use and modify additional parts that are included with your Newport in order to complete the installation.

**Make sure you test the fitment before installing.**

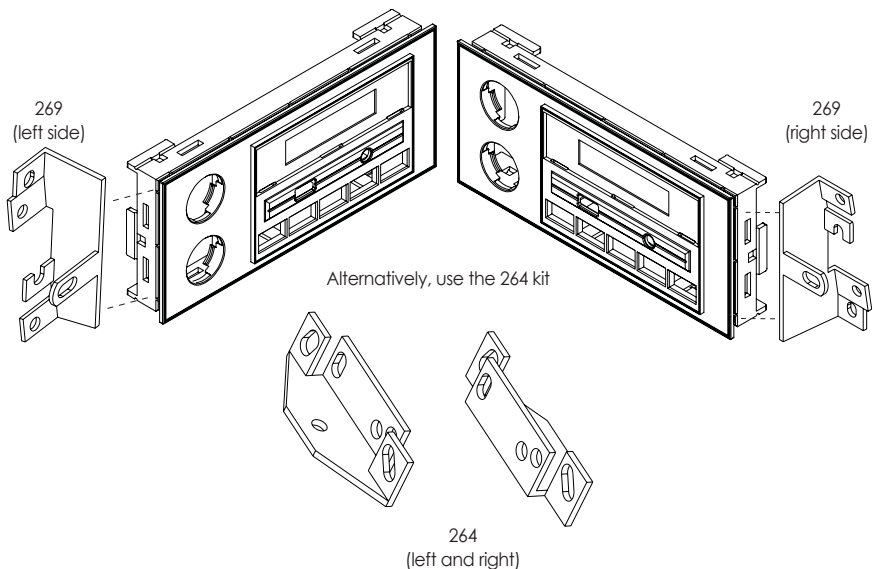

# WIRING CODES

---

In your vehicle specific kit, you'll find a wiring harness for your vehicle. This wiring harness plugs directly into your factory wiring harness. Listed below are the vehicle specific color codes from your factory wiring harness. These are for reference only. Always make sure to test your wiring to ensure that they are correct. If your vehicle is equipped with a factory Delco/Bose sound system, you will require a special adapter to install your Newport if you wish to retain your factory amplified speaker system.

## GENERAL MOTORS

Memory (+12 volt constant) Orange

Ignition (+12 volt switched) Yellow

Ground (-) Black

Illumination Gray

Dimmer Brown

Power Antenna Pink

## Speakers

Right Front (+) Light Green

Right Front (-) Dark Green

Left Front (+) Tan

Left Front (-) Gray

Right Rear (+) Dark Blue

Right Rear (-) Light Blue

Left Rear (+) Brown

Left Rear (-) Yellow

# 262 KIT

---

## Installation instructions for:

- Cadillac Escalade 1999-02
- Chevrolet Astro 1996-02
- Chevrolet C/K Pickup 1995-02
- Chevrolet Express 1996-00
- Chevrolet Silverado 1999-02
- Chevrolet Suburban 1995-02
- Chevrolet Tahoe 1995-02
- GMC Sierra 1996-02
- GMC Safari 1985-89
- GMC Savana 1996-00
- GMC Suburban 1995-02
- GMC Yukon 1995-02

Once the original radio is removed, use the included nuts and bolts to fasten the brackets to the sides of the radio. You may need to use and modify additional parts that are included with your Newport in order to complete the installation.

**Make sure you test the fitment before installing.**

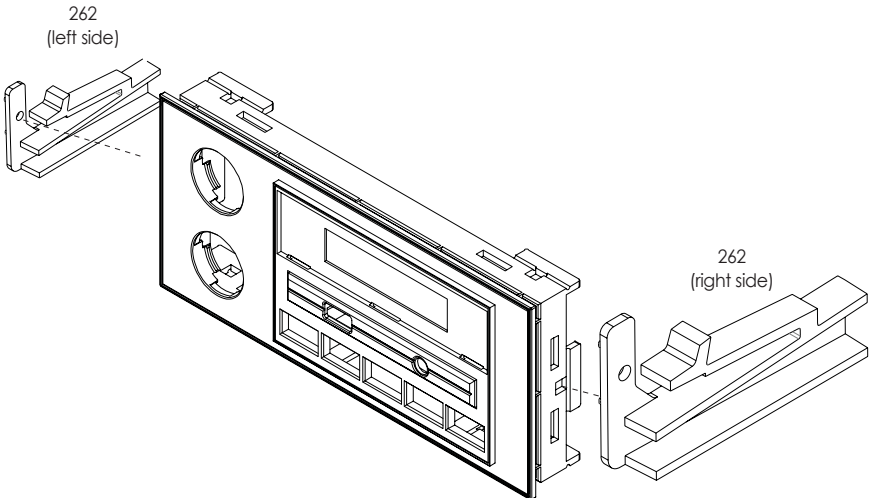

# WIRING CODES

---

In your vehicle specific kit, you'll find a wiring harness for your vehicle. This wiring harness plugs directly into your factory wiring harness. Listed below are the vehicle specific color codes from your factory wiring harness. These are for reference only. Always make sure to test your wiring to ensure that they are correct. If your vehicle is equipped with a factory Delco/Bose sound system, you will require a special adapter to install your Newport if you wish to retain your factory amplified speaker system.

## GENERAL MOTORS

Memory (+12 volt constant) Orange

Ignition (+12 volt switched) Yellow

Ground (-) Black

Illumination Gray

Dimmer Brown

Power Antenna Pink

## Speakers

Right Front (+) Light Green

Right Front (-) Dark Green

Left Front (+) Tan

Left Front (-) Gray

Right Rear (+) Dark Blue

Right Rear (-) Light Blue

Left Rear (+) Brown

Left Rear (-) Yellow

# 264 KIT

---

## Installation instructions for:

- Chevrolet Camaro 1982-92
- Chevrolet El Camino 1985-88
- Chevrolet Monte Carlo 1985-88
- Oldsmobile Omega 1983-84
- Pontiac Firebird 1982-92

Once the original radio is removed, use the included nuts and bolts to fasten the brackets to the sides of the radio. You may need to use and modify additional parts that are included with your Newport in order to complete the installation.

**Make sure you test the fitment before installing.**

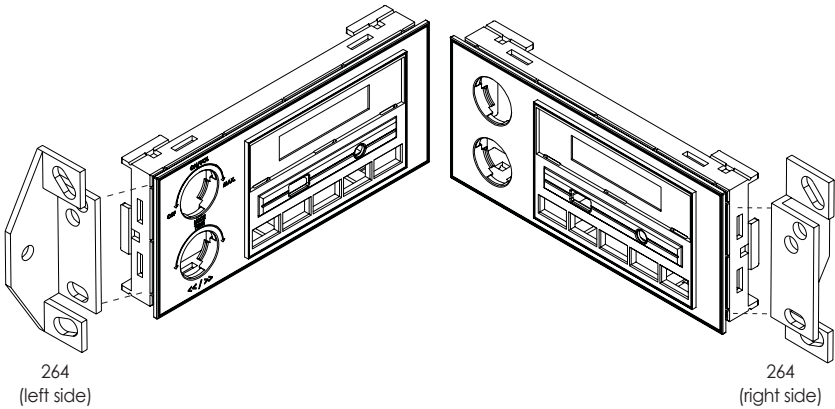

# WIRING CODES

---

In your vehicle specific kit, you'll find a wiring harness for your vehicle. This wiring harness plugs directly into your factory wiring harness. Listed below are the vehicle specific color codes from your factory wiring harness. These are for reference only. Always make sure to test your wiring to ensure that they are correct. If your vehicle is equipped with a factory Delco/Bose sound system, you will require a special adapter to install your Newport if you wish to retain your factory amplified speaker system.

## GENERAL MOTORS

Memory (+12 volt constant) Orange

Ignition (+12 volt switched) Yellow

Ground (-) Black

Illumination Gray

Dimmer Brown

Power Antenna Pink

## Speakers

Right Front (+) Light Green

Right Front (-) Dark Green

Left Front (+) Tan

Left Front (-) Gray

Right Rear (+) Dark Blue

Right Rear (-) Light Blue

Left Rear (+) Brown

Left Rear (-) Yellow

# 264/269/265 KIT

## Installation instructions for:

- Chevrolet Lumina APV 1990-96
- Oldsmobile Silhouette 1990-96
- Pontiac Grand Prix 1990-93
- Pontiac Trans Sport 1990-96
- Saturn SC Sports Coupe 1991-94
- Saturn SL Sedan 1991-94
- Saturn SW Wagon 1993-94

Once the original radio is removed, be sure to **keep the factory brackets**. If the original brackets are lost or missing, follow the guide below. You may need to use and modify additional parts that are included with your Newport in order to complete the installation.

**Make sure you test the fitment before installing.**

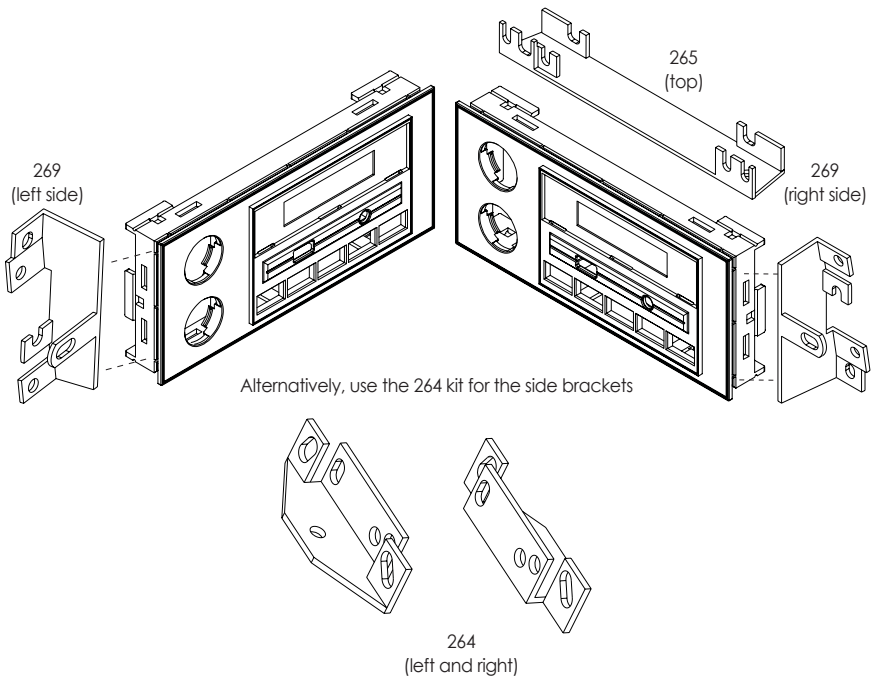

# WIRING CODES

---

In your vehicle specific kit, you'll find a wiring harness for your vehicle. This wiring harness plugs directly into your factory wiring harness. Listed below are the vehicle specific color codes from your factory wiring harness. These are for reference only. Always make sure to test your wiring to ensure that they are correct. If your vehicle is equipped with a factory Delco/Bose sound system, you will require a special adapter to install your Newport if you wish to retain your factory amplified speaker system.

## GENERAL MOTORS

Memory (+12 volt constant) Orange

Ignition (+12 volt switched) Yellow

Ground (-) Black

Illumination Gray

Dimmer Brown

Power Antenna Pink

## Speakers

Right Front (+) Light Green

Right Front (-) Dark Green

Left Front (+) Tan

Left Front (-) Gray

Right Rear (+) Dark Blue

Right Rear (-) Light Blue

Left Rear (+) Brown

Left Rear (-) Yellow



# 266/271 KIT

---

## Installation instructions for:

- Chevrolet Beretta 1991-96
- Chevrolet Corsica 1991-96

Once the original radio is removed, be sure to **keep the factory brackets**. If the original brackets are lost or missing, follow the guide below. You may need to use and modify additional parts that are included with your Newport in order to complete the installation.

**Make sure you test the fitment before installing.**

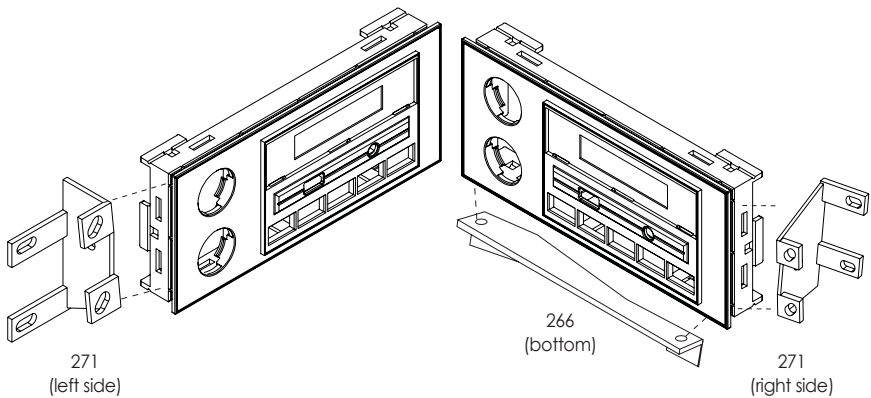

# WIRING CODES

---

In your vehicle specific kit, you'll find a wiring harness for your vehicle. This wiring harness plugs directly into your factory wiring harness. Listed below are the vehicle specific color codes from your factory wiring harness. These are for reference only. Always make sure to test your wiring to ensure that they are correct. If your vehicle is equipped with a factory Delco/Bose sound system, you will require a special adapter to install your Newport if you wish to retain your factory amplified speaker system.

## GENERAL MOTORS

Memory (+12 volt constant) Orange  
Ignition (+12 volt switched) Yellow  
Ground (-) Black  
Illumination Gray  
Dimmer Brown  
Power Antenna Pink

## Speakers

Right Front (+) Light Green  
Right Front (-) Dark Green  
Left Front (+) Tan  
Left Front (-) Gray  
Right Rear (+) Dark Blue  
Right Rear (-) Light Blue  
Left Rear (+) Brown  
Left Rear (-) Yellow

# 267/271 Kit

---

## Installation instructions for:

- Buick Roadmaster 1991-94
- Cadillac Cimarron 1982-88
- Chevrolet Caprice 1991-93
- Chevrolet Cavalier 1982-90
- Pontiac Sunbird J-2000 1982-88

Once the original radio is removed, be sure to **keep the factory brackets**. If the original brackets are lost or missing, follow the guide below. You may need to use and modify additional parts that are included with your Newport in order to complete the installation.

**Make sure you test the fitment before installing.**

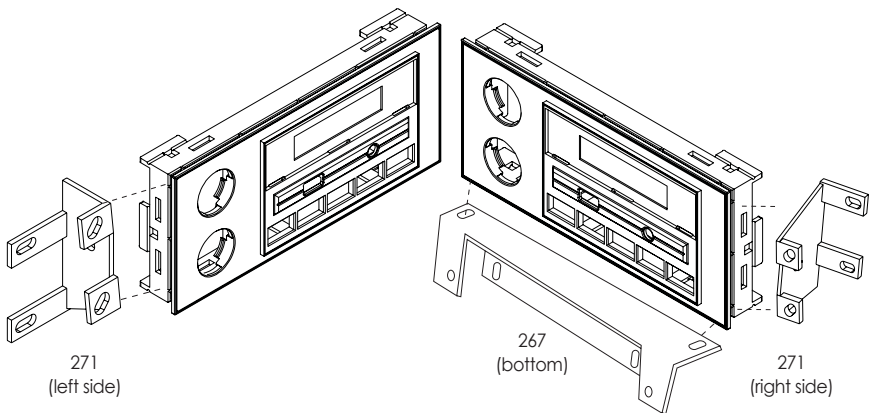

# WIRING CODES

---

In your vehicle specific kit, you'll find a wiring harness for your vehicle. This wiring harness plugs directly into your factory wiring harness. Listed below are the vehicle specific color codes from your factory wiring harness. These are for reference only. Always make sure to test your wiring to ensure that they are correct. If your vehicle is equipped with a factory Delco/Bose sound system, you will require a special adapter to install your Newport if you wish to retain your factory amplified speaker system.

## GENERAL MOTORS

Memory (+12 volt constant) Orange

Ignition (+12 volt switched) Yellow

Ground (-) Black

Illumination Gray

Dimmer Brown

Power Antenna Pink

## Speakers

Right Front (+) Light Green

Right Front (-) Dark Green

Left Front (+) Tan

Left Front (-) Gray

Right Rear (+) Dark Blue

Right Rear (-) Light Blue

Left Rear (+) Brown

Left Rear (-) Yellow

# 268/271 KIT

---

## Installation instructions for:

- Chevrolet Astro 1985-89
- GMC Safari 1985-89

Once the original radio is removed, be sure to **keep the factory brackets**. If the original brackets are lost or missing, follow the guide below. You may need to use and modify additional parts that are included with your Newport in order to complete the installation.

**Make sure you test the fitment before installing.**

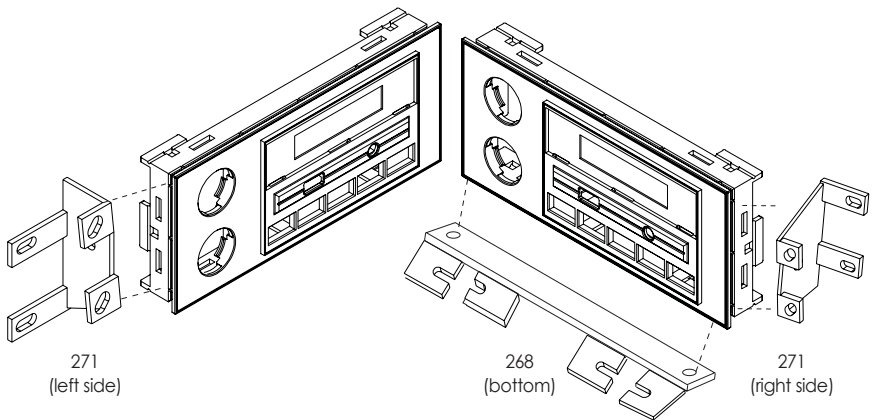

# WIRING CODES

---

In your vehicle specific kit, you'll find a wiring harness for your vehicle. This wiring harness plugs directly into your factory wiring harness. Listed below are the vehicle specific color codes from your factory wiring harness. These are for reference only. Always make sure to test your wiring to ensure that they are correct. If your vehicle is equipped with a factory Delco/Bose sound system, you will require a special adapter to install your Newport if you wish to retain your factory amplified speaker system.

## GENERAL MOTORS

Memory (+12 volt constant) Orange

Ignition (+12 volt switched) Yellow

Ground (-) Black

Illumination Gray

Dimmer Brown

Power Antenna Pink

## Speakers

Right Front (+) Light Green

Right Front (-) Dark Green

Left Front (+) Tan

Left Front (-) Gray

Right Rear (+) Dark Blue

Right Rear (-) Light Blue

Left Rear (+) Brown

Left Rear (-) Yellow

# 269 KIT

---

## Installation instructions for:

- Chevrolet Astro 1990-95
- Chevrolet Nova 1985-88
- Chevrolet Van (full size) 1988-95
- GMC Safari 1990-95
- GMC Van (full size) 1988-95

Once the original radio is removed, use the included nuts and bolts to fasten the brackets to the sides of the radio. You may need to use and modify additional parts that are included with your Newport in order to complete the installation.

**Make sure you test the fitment before installing.**

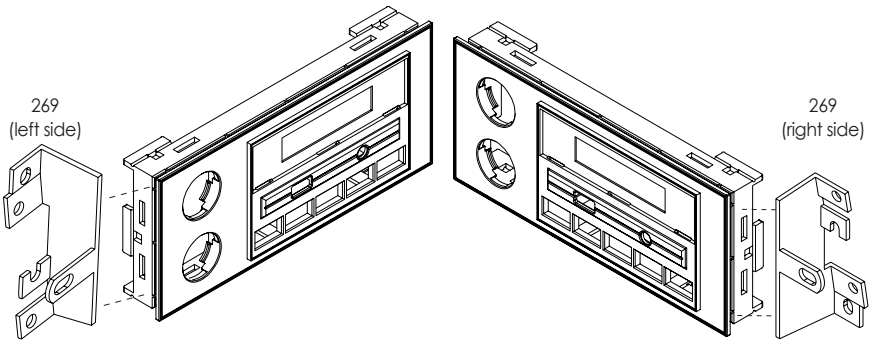

# WIRING CODES

---

In your vehicle specific kit, you'll find a wiring harness for your vehicle. This wiring harness plugs directly into your factory wiring harness. Listed below are the vehicle specific color codes from your factory wiring harness. These are for reference only. Always make sure to test your wiring to ensure that they are correct. If your vehicle is equipped with a factory Delco/Bose sound system, you will require a special adapter to install your Newport if you wish to retain your factory amplified speaker system.

## GENERAL MOTORS

Memory (+12 volt constant) Orange

Ignition (+12 volt switched) Yellow

Ground (-) Black

Illumination Gray

Dimmer Brown

Power Antenna Pink

## Speakers

Right Front (+) Light Green

Right Front (-) Dark Green

Left Front (+) Tan

Left Front (-) Gray

Right Rear (+) Dark Blue

Right Rear (-) Light Blue

Left Rear (+) Brown

Left Rear (-) Yellow



# 271 KIT

Once the original radio is removed, use the included nuts and bolts to fasten the brackets to the sides of the radio. You may need to use and modify additional parts that are included with your Newport in order to complete the installation.

**Make sure you test the fitment before installing.**

## Installation instructions for:

- Chevrolet Lumina 1990-94
- Chevrolet S10 Blazer 1982-85
- Chevrolet S10 Pickup 1982-85
- GMC S15 Jimmy 1982-85
- GMC S15 Pickup 1982-85
- Pontiac 6000 1982-91

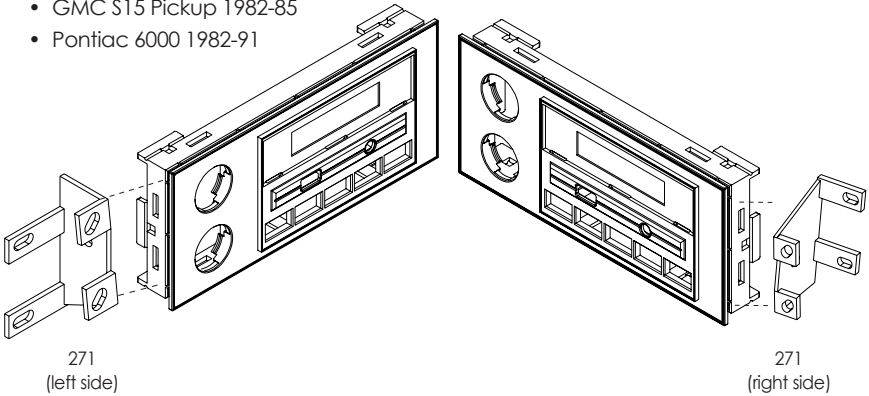

## Installation instructions for:

- Chevrolet S10 Pickup 1986-93
- Chevrolet S10 Blazer 1986-94
- GMC S15 Pickup 1985-93
- GMC S15 Jimmy 1986-94
- Oldsmobile Bravada 1991-94

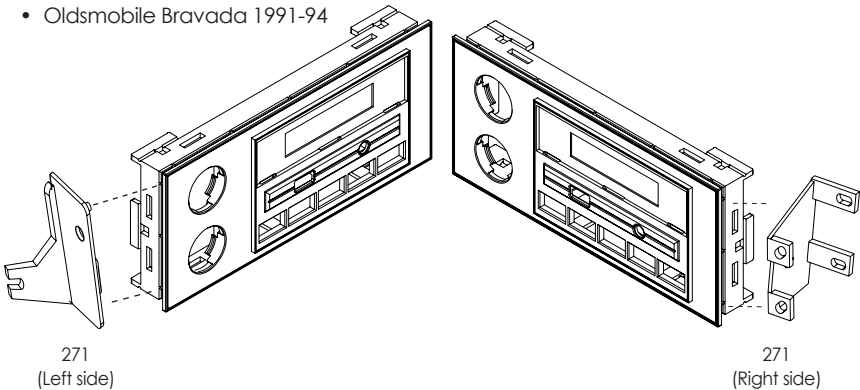

# WIRING CODES

---

In your vehicle specific kit, you'll find a wiring harness for your vehicle. This wiring harness plugs directly into your factory wiring harness. Listed below are the vehicle specific color codes from your factory wiring harness. These are for reference only. Always make sure to test your wiring to ensure that they are correct. If your vehicle is equipped with a factory Delco/Bose sound system, you will require a special adapter to install your Newport if you wish to retain your factory amplified speaker system.

## GENERAL MOTORS

Memory (+12 volt constant) Orange  
Ignition (+12 volt switched) Yellow  
Ground (-) Black  
Illumination Gray  
Dimmer Brown  
Power Antenna Pink

## Speakers

Right Front (+) Light Green  
Right Front (-) Dark Green  
Left Front (+) Tan  
Left Front (-) Gray  
Right Rear (+) Dark Blue  
Right Rear (-) Light Blue  
Left Rear (+) Brown  
Left Rear (-) Yellow

# 272 KIT

---

## Installation instructions for:

- Chevrolet Camaro 1997-99
- Chevrolet Caprice 1994-96
- Chevrolet Cavalier 1995-99
- Chevrolet Corvette 1997-02
- Chevrolet Impala SS 1994-96
- Chevy Lumina 1995-99
- Chevrolet Malibu 1997-99
- Chevrolet Monte Carlo 1995-99
- Chevrolet S10 Blazer 1998-02
- Chevrolet S10 Pickup 1998-02
- Chevrolet Venture 1997-99
- GMC S15 Jimmy 1998-02
- GMC Sonoma 1998-02
- Oldsmobile Silhouette 1997-99
- Pontiac Montana 1999
- Pontiac Transport 1997-98

Once the original radio is removed, use the included nuts and bolts to fasten the brackets to the sides of the radio. You may need to use and modify additional parts that are included with your Newport in order to complete the installation.

**Make sure you test the fitment before installing.**

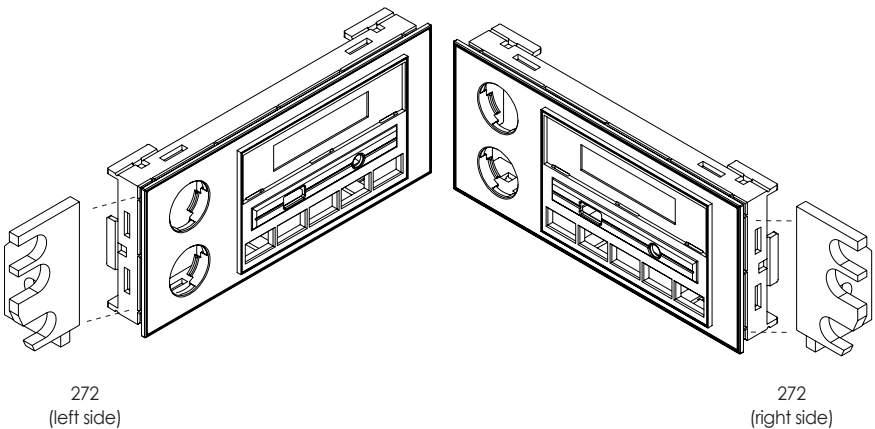

# WIRING CODES

---

In your vehicle specific kit, you'll find a wiring harness for your vehicle. This wiring harness plugs directly into your factory wiring harness. Listed below are the vehicle specific color codes from your factory wiring harness. These are for reference only. Always make sure to test your wiring to ensure that they are correct. If your vehicle is equipped with a factory Delco/Bose sound system, you will require a special adapter to install your Newport if you wish to retain your factory amplified speaker system.

## GENERAL MOTORS

Memory (+12 volt constant) Orange  
Ignition (+12 volt switched) Yellow  
Ground (-) Black  
Illumination Gray  
Dimmer Brown  
Power Antenna Pink

## Speakers

Right Front (+) Light Green  
Right Front (-) Dark Green  
Left Front (+) Tan  
Left Front (-) Gray  
Right Rear (+) Dark Blue  
Right Rear (-) Light Blue  
Left Rear (+) Brown  
Left Rear (-) Yellow

# 273 KIT

---

## Installation instructions for:

- Pontiac Bonneville 1994-99
- Pontiac Firebird 1993-02
- Pontiac Grand Am 1996-00
- Pontiac Grand Prix 1994-00
- Pontiac Sunfire 1995-99

Once the original radio is removed, use the included nuts and bolts to fasten the brackets to the sides of the radio. You may need to use and modify additional parts that are included with your Newport in order to complete the installation.

**Make sure you test the fitment before installing.**

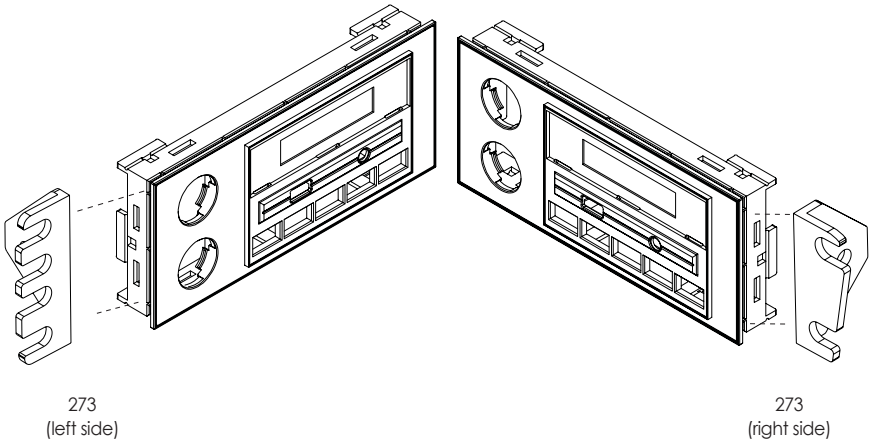

# WIRING CODES

---

In your vehicle specific kit, you'll find a wiring harness for your vehicle. This wiring harness plugs directly into your factory wiring harness. Listed below are the vehicle specific color codes from your factory wiring harness. These are for reference only. Always make sure to test your wiring to ensure that they are correct. If your vehicle is equipped with a factory Delco/Bose sound system, you will require a special adapter to install your Newport if you wish to retain your factory amplified speaker system.

## GENERAL MOTORS

Memory (+12 volt constant) Orange

Ignition (+12 volt switched) Yellow

Ground (-) Black

Illumination Gray

Dimmer Brown

Power Antenna Pink

## Speakers

Right Front (+) Light Green

Right Front (-) Dark Green

Left Front (+) Tan

Left Front (-) Gray

Right Rear (+) Dark Blue

Right Rear (-) Light Blue

Left Rear (+) Brown

Left Rear (-) Yellow

# *Newport*

270 KIT



MODERN SOUND FOR YOUR CLASSIC

[www.retromanufacturing.com](http://www.retromanufacturing.com)

# 270 KIT

## Installation instructions for:

- Chrysler Cirrus 1995-00
- Chrysler Concorde 1993-97
- Chrysler Cordoba 1975-83
- Chrysler E-Class 1983-97
- Chrysler 5th Avenue 1979-93
- Chrysler Imperial 1982-83
- Chrysler Imperial 1990-93
- Chrysler Laser 1984-89
- Chrysler LeBaron 1977-95
- Chrysler LeBaron GTS 1985-95
- Chrysler LHS 1995-98
- Chrysler Neon 1995-99
- Chrysler Newport 1977-1981
- Chrysler New Yorker 1975-96
- Chrysler Sebring (convertible) 1996-00
- Chrysler Sebring 1995-00
- Chrysler Town & Country 1990-00
- Dodge Aries 1981-89
- Dodge Aspen 1976-80
- Dodge Avenger 1995-00
- Dodge Caravan 1984-00
- Dodge Charger 1974-78
- Dodge Charger 1981-87
- Dodge Dakota 1987-00
- Dodge Daytona 1984-93
- Dodge Diplomat 1976-89
- Dodge Durango 1997-00
- Dodge Dynasty 1988-93
- Dodge Intrepid 1993-97
- Dodge Lancer 1986-89
- Dodge Magnum XE 1978-79
- Dodge Mirada 1979-89
- Dodge Neon 1995-99
- Dodge Omni 1978-90
- Dodge Pickup 1974-83
- Dodge Ram 1994-01
- Dodge Ramcharger 1974-93
- Dodge Rampage 1978-82
- Dodge Shadow 1987-95
- Dodge Spirit 1989-95
- Dodge Stratus 1995-99
- Dodge St. Regis 1979-81
- Dodge Van 1978-03
- Dodge 024 1978-82
- Dodge 400 1982-83
- Dodge 600 1983-87
- Eagle Vision 1993-97
- Ford Aerostar 1985-91
- Ford Country Squire 1979-89
- Ford Crown Victoria 1983-89
- Ford LTD 1979-86
- Ford Ranger (mini) 1983-88
- Ford Thunderbird 1980-88
- Jeep Cherokee 1997-01
- Jeep Grand Cherokee 1993-98
- Jeep Wrangler 1997-02
- Lincoln Continental 1985-89
- Lincoln Mark VII 1984-88
- Mercury Colony Park 1979-89
- Mercury Cougar 1983-88
- Mercury Cougar XR7 1980-82
- Mercury Grand Marquis 1979-85
- Mercury Marquis 1979-88
- Plymouth Acclaim 1989-95
- Plymouth Breeze 1996-99
- Plymouth Caravelle 1985-87
- Plymouth Fury 1975-78
- Plymouth Gran Fury 1978-89
- Plymouth Horizon 1978-83
- Plymouth Neon 1994-99
- Plymouth Reliant 1981-89
- Plymouth Scamp 1983-84
- Plymouth Sundance 1987-94
- Plymouth TC3 1978-82
- Plymouth Trailduster 1975-81
- Plymouth Turismo 1983-87
- Plymouth Van 1978-80
- Plymouth Voyager 1984-00



# 270 KIT

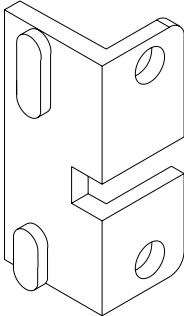

Bracket #1

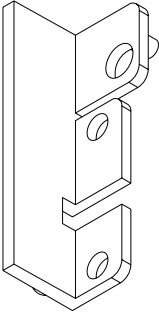

Bracket #2

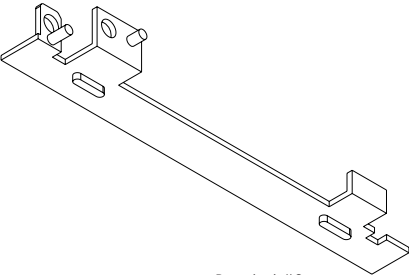

Bracket #3

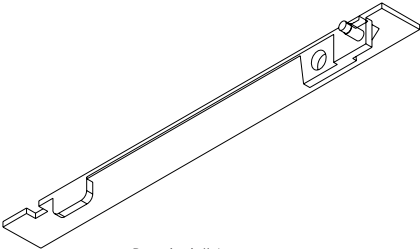

Bracket #4

# 270 KIT

## Installation instructions for:

- All Chrysler, Dodge, Eagle, Jeep and Plymouth Vehicles listed on page 1 (except Cirrus, Sebring, Sebring Convertible, Avenger, Breeze and 1993-95 Grand Cherokee)

Once the original radio has been removed, use the included nuts and bolts to fasten the brackets to the top, bottom and right side of your Newport.

**Make sure to test fit the radio first before mounting or modifying the brackets.**

For this installation you will use the tabs circled in the diagram. To fit your vehicle you will need to remove all of the other plastic tabs on the brackets. You may also need to use and/or modify additional parts included with your Newport to complete the installation. Again, make sure to test the fitment before installing.

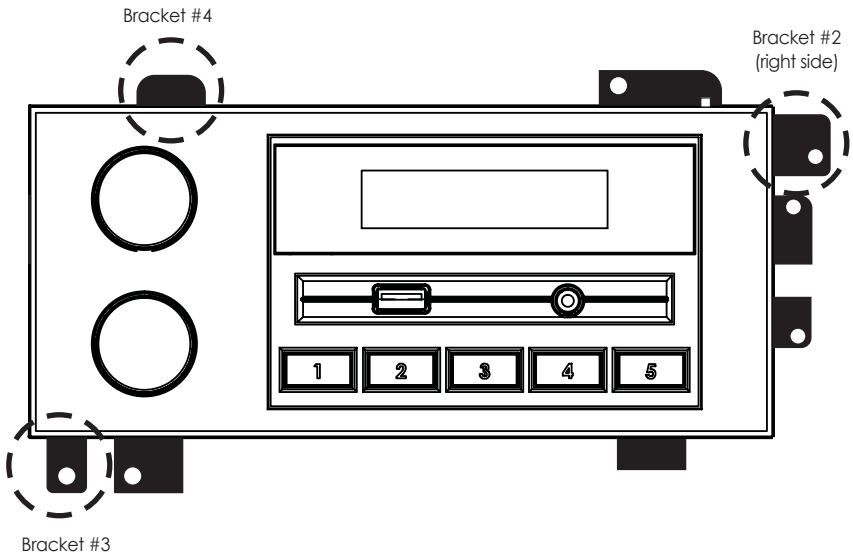

# 270 KIT

## Installation instructions for:

- Chrysler Cirrus 1995-00
- Chrysler Sebring (convertible) 1996-00
- Dodge Stratus 1995-99
- Plymouth Breeze 1996-99

Once the original radio has been removed, use the included nuts and bolts to fasten the brackets to the top, bottom and sides of your Newport.

**Make sure to test fit the radio first before mounting or modifying the brackets.**

For this installation you will use the tabs circled in the diagram. To fit your vehicle you will need to remove all of the other plastic tabs on the brackets. You may also need to use and/or modify additional parts included with your Newport to complete the installation. Again, make sure to test the fitment before installing.

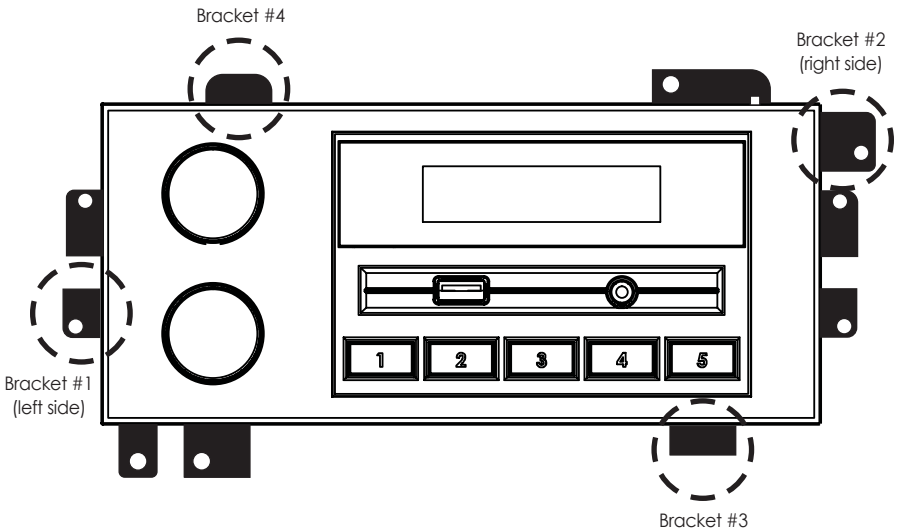

# 270 KIT

## Installation instructions for:

- Chrysler Sebring 1995-00
- Dodge Avenger 1995-00
- Jeep Grand Cherokee 1993-95

Once the original radio has been removed, use the included nuts and bolts to fasten the brackets to the top and bottom of your Newport.

**Make sure to test fit the radio first before mounting or modifying the brackets.**

For this installation you will use the tabs circled in the diagram. To fit your vehicle you will need to remove all of the other plastic tabs on the brackets. You may also need to use and/or modify additional parts included with your Newport to complete the installation. Again, make sure to test the fitment before installing.

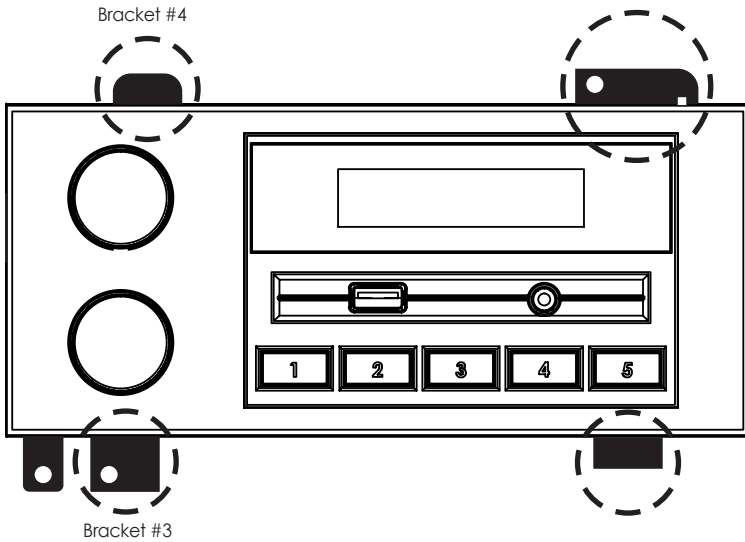

# 270 KIT

## Installation instructions for:

- All Ford/Lincoln/Mercury Vehicles listed on page 1 1974-03

Once the original radio has been removed, use the included nuts and bolts to fasten the brackets to the bottom and sides of your Newport.

**Make sure to test fit the radio first before mounting or modifying the brackets.**

For this installation you will use the tabs circled in the diagram. To fit your vehicle you will need to remove all of the other plastic tabs on the brackets. You may also need to use and/or modify additional parts included with your Newport to complete the installation. Again, make sure to test the fitment before installing.

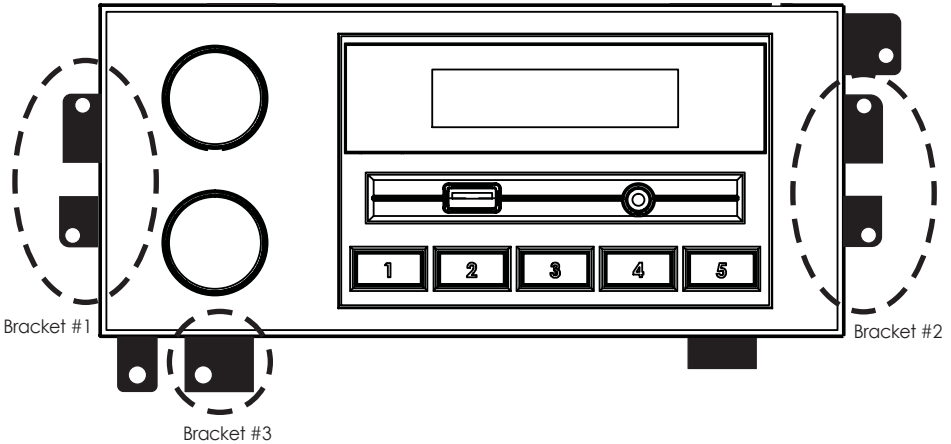

# WIRING CODES

---

In your vehicle specific kit, you'll find a wiring harness for your vehicle. This wiring harness plugs directly into your factory wiring harness. Listed below are the vehicle specific color codes from your factory wiring harness. These are for reference only. Always make sure to test your wiring to ensure that they are correct. If your vehicle is equipped with a factory Delco/Bose sound system, you will require a special adapter to install your Newport if you wish to retain your factory amplified speaker system.

## FORD/LINCOLN/MERCURY

Some late 70's to early 80's Fords may have a factory common ground system. You may need to re-wire the speakers or purchase a common ground adapter from your local car audio retailer.

### Power

Memory (+12 volt constant) Green/Yellow  
Ignition (+12 volt switched) Yellow/Black  
Ground (-) Black or Fat Red  
Illumination Orange  
Dimmer Orange/White  
Power Antenna Blue (varies greatly)

### Speakers

Right front (+) White/Green  
Right Front (-) Green/Orange  
Left Front (+) Orange/Green  
Left Front (-) Light Blue  
Right Rear (+) Pink/Blue  
Right Rear (-) Pink/Blue

## DODGE/CHRYSLER/PLYMOUTH

Memory (+12 volt constant ) Red/White  
Ignition (+12 volt switched) Red  
Ground (-) Black or Braided Silver  
Illumination Orange  
Dimmer (none)  
Power Antenna Yellow

### Speakers

Right Front (+) Violet  
Right Front (-)Blue/Red  
Left Front (+) Green  
Left Front (-) Brown/Red  
Right Rear (+) Blue/White  
Right Rear (-) Blue/Red  
Left Rear (+) Brown/Yellow  
Left Rear (-) Brown/Red

## JEEP/EAGLE

### Power

Memory (+12 volt constant) Pink  
Ignition (+12 volt switched) Violet/White  
Ground (-) Black  
Illumination Orange  
Dimmer Blue/White  
Power Antenna None

### Speakers

Right Front (+) White  
Right Front (-) Black  
Left Front (+) Green  
Left Front (-) Black/Yellow  
Right Rear (+) White/Black  
Right Rear (-) Brown  
Left Rear (+) Green/White  
Left Rear (-) Brown/White