

# **naxa<sup>®</sup>**

## **INSTRUCTION MANUAL**

**PORTABLE CD PLAYER WITH STEREO  
RADIO CASSETTE RECORDER**

**MODEL: NPB-426**



# IMPORTANT NOTES

## INTRODUCTION

Thank you for buying this product.

Please read through these operating instructions, so you will know to operate your equipment properly. After you finished reading the instructions manual, put it away in a safe place for future reference.

## WARNING

To prevent fire or shock hazard, do not expose this appliance to rain or moisture. To avoid electrical shock, do not open the cabinet, refer servicing to qualified personnel only.

## CAUTION

Use of controls or adjustment or performance of procedures other than those specified herein may result in hazardous radiation exposure.

## DANGER

Invisible laser radiation when open and interlock failed or defeated. Avoid direct exposure to beam.

CLASS 1 LASER PRODUCT  
LUOKAN 1 LASERLAITE  
KLASS 1 LASERAPPARAT

This Compact disc player is classified as a Class 1 LASER PRODUCT.

THE CLASS 1 LASER PRODUCT label is located on the rear exterior.

NOTE: The manufacturer is not responsible for any radio or TV interference caused by unauthorized modifications could void the user's authority to operate the equipment.

Avoid installing the unit in locations described below:

1. Places exposed to direct sunlight or close to heat radiating appliances such as electric heaters, on top of other stereo equipment that radiate too much heat.
2. Places locking ventilation or dusty places.
3. Places subject to constant vibration.
4. Humid or moist places.

Operate turning controls and switches as instructed in the manual.

Before turning on the power for the first time, make sure that the power cord is properly installed.

Store your tapes or CD in a cool area to avoid damage from heat.

**CAUTION:** TO REDUCE THE RISK OF ELECTRIC SHOCK, DO NOT REMOVE COVER (OR BACK). NO USER SERVICEABLE PARTS INSIDE, REFER SERVICING TO QUALIFIED SERVICE PERSONNEL.

## WARNING:

Remove batteries if exhausted or if they will not be used again for a long period.

The incorrect use of batteries can cause electrolyte leakage and will corrode the compartment or cause the batteries to burst. Therefore:

Do not mix battery types, e.g. alkaline with zinc carbonate.

When inserting new batteries, replace all batteries at the same time.

## LOCATION OF CONTROLS

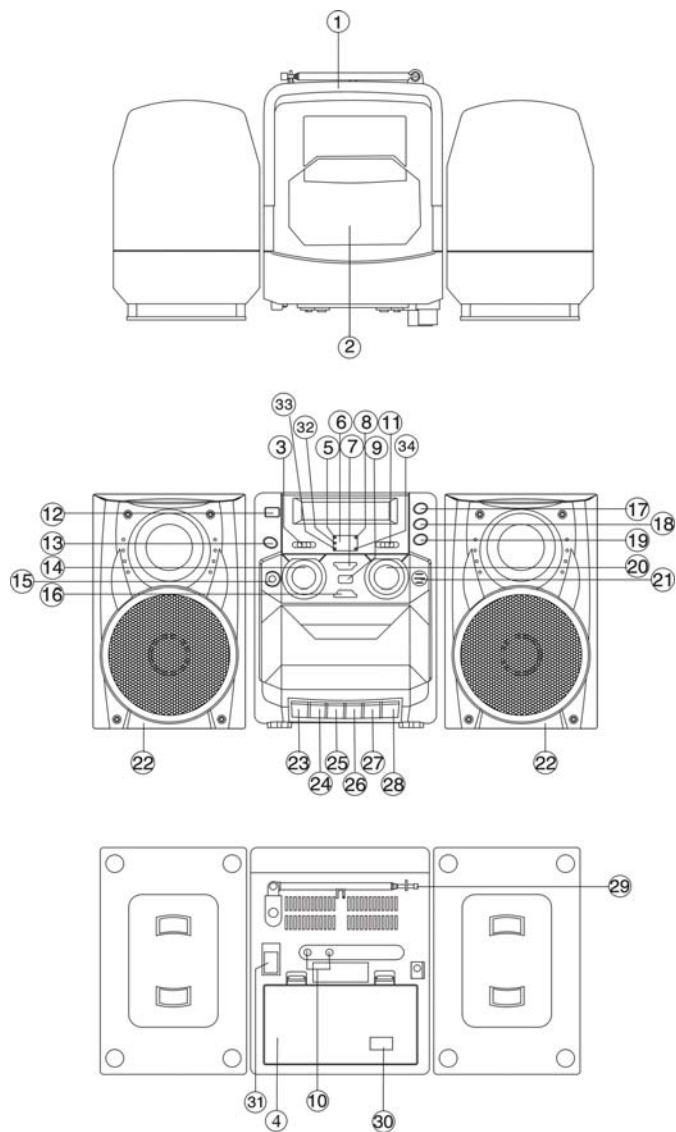

## FEATURES AND CONTROLS

1. HANDLE
2. CD COMPARTMENT
3. FUNCTION SWITCH
4. BATTERY COMPARTMENT
5. STANDBY INDICATOR
6. LED DISPLAY
7. CD STOP BUTTON
8. FM STEREO INDICATOR
9. CD PLAY/PAUSE BUTTON
10. SPEAKER JACK (L&R)
11. BAND SELECTOR
12. STANDBY BUTTON
13. X-BASS BUTTON
14. VOLUME CONTROL
15. AUX IN JACK
16. CD PROGRAM BUTTON
17. CD SKIP/SEARCH NEXT BUTTON
18. CD SKIP/SEARCH BACK BUTTON
19. CD REPEAT BUTTON
20. TUNING CONTROL
21. BUILT-IN CONDENSER MIC.
22. SPEAKERS
23. CASSETTE RECORD BUTTON
24. CASSETTE PLAY BUTTON
25. CASSETTE REWIND BUTTON
26. CASSETTE FAST FORWARD BUTTON
27. CASSETTE STOP/EJECT BUTTON
28. CASSETTE PAUSE BUTTON
29. FM TELESCOPIC ANTENNA
30. AC VOLTAGE SELECTOR (FOR DUAL VOLTAGE VERSION)
31. AC SOCKET
32. REPEAT INDICATOR
33. PROGRAM INDICATOR
34. PLAY/PAUSE INDICATOR

## POWER SUPPLY

### 1. BATTERY OPERATION

REMOVE THE BATTERY COMPARTMENT DOOR.

INSERT 8 PIECES UM-1 (D SIZE) BATTERIES INTO THE BATTERY COMPARTMENT WITH BATTERY POLARITY POSITIONED AS INDICATED. NOTE: WE RECOMMEND THE USE OF ALKALINE BATTERIES.

CLOSE THE BATTERY COMPARTMENT DOOR.

### 2. AC OPERATION

THE AC POWER CORD IS LOCATED INSIDE THE BATTERY COMPARTMENT.

PLUG THE AC LINE CORD INTO ANY NORMAL HOUSEHOLD AS MAINS OUTLET IN CORRECT VOLTAGE AND THE MAINS SOCKET

**NOTE:** FOR DUAL VOLTAGE VERSION, MAKE SURE THAT THE AC VOLTAGE SELECTOR (LOCATED ON THE BOTTOM OF THE UNIT) IS SWITCHED TO YOUR LOCAL VOLTAGE.(OPTIONAL)

## RADIO OPERATION

Set FUNCTION SWITCH to "RADIO" position.

### FM/FM ST. BAND

Select FM ST. mode by band selector switch. Turn the TUNING control to select the desired station. The FM stereo indicator will light up which shows a FM stereo broadcast is being received, fully extend the FM antenna and adjust its direction for best FM reception.

### AM BAND

Select AM mode by band selector switch. Turn the TUNING control to select the desired station. For AM reception, the set is controlled by a built-in ferrite aerial which is directional. Therefore, the set should be positioned for the best signal strength.

## **CASSETTE OPERATION**

### **PLAYBACK OF CASSETTE**

Be sure to tighten any slack tape in the cassette before use, using either a pencil or a ballpoint pen, simply insert the pen or pencil into the center of spool and rotate to remove slacks. Depress the STOP/EJECT button to open the cassette door.

Insert the cassette into the compartment with the open end facing upwards and the full reel on the left hand side, push the cassette well down and close the door, be sure not to touch the tape surface, Set the Function switch to "TAPE" position and press the cassette play button. To stop playback, press the STOP/EJECT button once. To release the cassette, press the STOP/EJECT button again.

### **AUTO STOP**

When the tape reaches the end during playback or recording, the built-in auto stop system will release the depressed play, record keys. The auto stop system operates while recording from the built-in radio or CD player, only the cassette function is brought automatically to stop mode and the radio or CD Player will continue to play.

### **TAPE RECORDING**

1. Install a cassette tape.
2. Set FUNCTION SWITCH to "TAPE" position. After selecting the desired band and tune the TUNING KNOB to desired broadcast station. Then push down RECORD BUTTON and PLAY BUTTON simultaneously.
3. After recording the desired broadcast, depress the STOP/EJECT BUTTON lightly, and then set FUNCTION SWITCH to "TAPE" position in order to listen to the recorded broadcast.
4. If you desire to play recorded broadcast, please follow the instructions explained in playback section.

ERASURE: When you record over previously recorded tape, the original recording is automatically erased and replaced by these newly recording materials.

Note: Tape recording is also available for CD playback (set FUNCTION SWITCH to "CD/AUX" position). See details in CD section.

### **RECORDING FROM BUILT-IN MIC**

1. Set the Function Switch to "TAPE" normal position.
2. Insert a blank cassette tape into the tape deck.
3. Press the RECORD key and the PLAY key simultaneously. You can start the recording through the built-in MIC.
4. To stop the recording manually, press the Stop/Eject Button.

### **TYPES OF CASSETTE**

Use only good quality cassettes (IEC TYPE 1) for making recordings. May be used to replay other types of cassette but is unable to make proper recording on these more specialized tapes. The use of C120 cassettes is NOT recommended in this machine.

## PROTECTING RECORDING

Normally, anything recorded on the tape is automatically erased when new recording is made. It is possible to protect your recording from accidental erasure by removing the tabs found on the rear of the cassette.

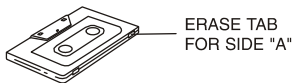

When the cassette is held with the recorded side upper-most and exposed tape facing the front, the protective tab will be found on the left rear of the cassette.

All pre-recorded cassette are protected in this way to prevent accidental erasure of the commercial recording. "Protected" cassette will prevent the record button from being operated. If at any time you attempt to record and find that this button will not depress, never force the mechanism or it may be damaged. Check that a cassette has been loaded and that tab has not been removed. Recording on a cassette from which the tabs have been removed can be done by covering the tab openings with a piece of adhesive tape.

## CARE OF CASSETTE MECHANISM

Gently clean the tape head and pinch wheel/capstan assemblies after every 10 hours of using the unit.

A range of cassette care products are available.

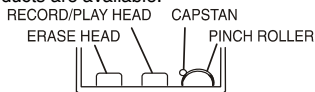

The erase head and record/play head and the surface of the pinch roller are delicate and must not be touched with metal objects such as screwdrivers. You may find it easier to clean the assembly by pressing the PLAY button to bright head and pinch roller into view. Be sure to press the STOP button after cleaning the mechanism.

Damage to the pinch wheel can occur if the unit is left in PLAY mode with the power switch off. Under no circumstances should you attempt to lubricate any part of the machine.

## LISTENING TO COMPACT DISC

Set FUNCTION SWITCH to "CD/AUX" position. Open the CD door to put in a compact disc. Close it and start reading. The LED digit always shows the tracks of a disc which are still to be played. Total number of tracks of the disc is shown in stop mode. If no disc loaded into the compartment, or the disc is placed upside down or unreadable, the display will show **NO**.

### Playing the Entire Disc

1. Playback will start by pressing CD PLAY/PAUSE button, playback starts with the first track. The display will show the current track number.
2. To interrupt playback, press CD PLAY/PAUSE button. The signal "PLAY" will be flashing.
3. To resume playback, press CD PLAY/PAUSE button once again.
4. To stop playback, press CD STOP button.

## Selecting a Different Track during Play

1. Press CD SKIP/SEARCH NEXT/BACK button on the unit continuously until the desired track number appears in the display.
2. Playback starts from the desired track. (Press CD PLAY/PAUSE button to start playback in stop mode)

## Starting Again With the Track That Is Currently Playing

1. Press CD SKIP/SEARCH BACK button once.
2. The playback will start again from the beginning of the track.

## Stopping Play

1. Press CD STOP button if you wish to stop play. The total track number which can be played will now appear in the display.
2. Open the CD door on the unit to remove the CD.

## REPEAT PLAY

When playing, press REPEAT button once. "REPEAT" indicator will be flashing the same track only. If repeat all tracks, press the REPEAT button again, "REPEAT" indicator will be on and steady. To cancel repeat play, press the REPEAT button until the "REPEAT" indicator disappear.

## PROGRAM PLAY

Programming tracks of disc are possible when playback is stopped. Up to 20 tracks can be stored in the memory in any order.

1. Press PROGRAM button to make program memory in stop mode.
2. PROGRAM indicator will be shown flashing on the display.
3. Press CD SKIP/SEARCH NEXT/BACK button to select a track number. The track number will show on display.
4. Press the PROGRAM button to store the track number.
5. PROGRAM indicator flashes again. Repeat step (3) to (4) to program other desired tracks.
6. Press PROGRAM button repeatedly and all the programmed track numbers will be shown one by one
7. Press CD PLAY/PAUSE button. Playback will start from the first programmed track.
8. You can press CD SKIP/SEARCH NEXT/BACK button to select the track number in memory.
9. In stop mode, press STOP button to cancel the programmed play.

## X-BASS SYSTEM

The X-BASS BUTTON controls the bass of the unit. Bass sound is the lower frequency ranges of sound. The knob can be pushed to OFF or ON position. When the X-BASS is on, the unit boosts (increases) the sound output of the bass frequencies.

## AUX IN OPERATION

This unit has provided special AUX IN jack, through this jack other audio sources can be connected to this unit and be amplified.

1. Set the FUNCTION switch to CD/AUX position.
2. Connect the audio cable into the AUX IN jack and the other end connecting to the AUDIO OUT jack of the external audio source. The unit will change to AUX mode automatically.
3. Adjust the volume of the main unit to your desired level.

Press PLAY of the external audio source (eg. MP3 player) to start playback.

## **SPECIFICATIONS**

### **GENERAL**

Power Requirement .....	AC 110/220V ~ 60/50Hz
	DC 12V UM-1 x 8 PCS
Power consumption.....	AC 17 Watts
Weight .....	Approx. 4.0kg
Dimensions.....	Approx. 455mm (W) x 220mm (H) x 240mm (D)
Operation temperature .....	+5° C - + 35 ° C

### **RECEIVER SECTION**

Receiving Bands .....	AM / FM
Tuning Range .....	AM 530 - 1710 KHz
	FM 88 - 108 MHz

### **COMPACT DISC SECTION**

Optical Pickup .....	3-Beam Laser
Frequency Response .....	100Hz – 16 KHz

### **CASSETTE SECTION**

Recording System .....	2 Tracks 2 channel (Stereo)
Biasing System .....	Magnet Erase
Frequency Response .....	125 – 6.3 KHz
Wow and Flutter .....	0.35 % WRMS (JIS)

### **AUDIO SECTION**

Power output .....	Maximum 2.5 Watts x 2
Headphone Impedance .....	4 – 32 Ohms

### **ACCESSORIES**

Instruction Booklet .....	1
---------------------------	---

### **Caution**

To avoid electric shock, this unit must not be exposed to dripping water splash.  
Ventilation warning - The normal ventilation of the product shall not be impeded for intended use.