

CARBON MONOXIDE ALARM

CAT. **C05120PDBN**



DIGITAL DISPLAY

Convenient display offers visual confirmation and remembers highest CO levels detected

10YR CO SENSOR
10YR ALARM LIFE

ELECTROCHEMICAL CO SENSOR

Most accurate technology available for detecting carbon monoxide as compared to other sensing technologies.

LATCHING ALARM INDICATOR

Remembers which unit initiated an alarm.

SILENCE FEATURE

Silences nuisance alarms.

END OF LIFE SIGNAL

Provides audible notice when alarm needs to be replaced after 10 years.



BRK[®]

THE PROFESSIONAL STANDARD

**120V AC, 60Hz Wire-in
with 9V Battery Backup**

Description:

The BRK Brands, Inc. model C05120PDBN is a wire-in, 120 VAC 60Hz single and / or multiple station carbon monoxide alarm specifically designed for residential and institutional applications including sleeping rooms of hospitals, hotels, motels, dormitories and other multi-family dwellings as defined in standard NFPA 101. Model C05120PDBN complies with UL2034, NFPA 720, HUD, FHA and other agencies that model their codes after the above agencies. They meet building codes where AC/DC carbon monoxide alarms are required either separately or in combination. The alarms are interconnectable up to 18 devices, of which 12 can be smoke alarms.

The BRK C05120PDBN features an electrochemical carbon monoxide sensor, a multi-function LCD digital display, an 85dB horn, 9V battery back-up, an End of Life and a silence feature. "Intelligent Sensing Technology" is designed to reduce nuisance alarms. The peak level function allows for easy viewing of highest CO levels detected. "Latching Alarm Indicator" remembers which unit initiated an alarm. When interconnected in a series, the unit that triggered the alarm will store in memory or "latch" the information and begin to flash the LED indicator 2 seconds on, 2 seconds off. A single button test/silence button eliminates confusion. Battery installation and removal can occur while the unit is mounted to the ceiling or wall via the side load battery compartment. Other Contractor Preferred features include a dust cover to keep alarm clean during construction, keyhole slots in the mounting bracket eliminate the need to remove the electrical box screws for installation. Two locking features are provided to prevent battery theft and/or theft of the unit. Connection to AC power is made with a "Quick-Connect" wiring harness. Installation is quick, easy and cost effective.



CAT. C05120PDBN

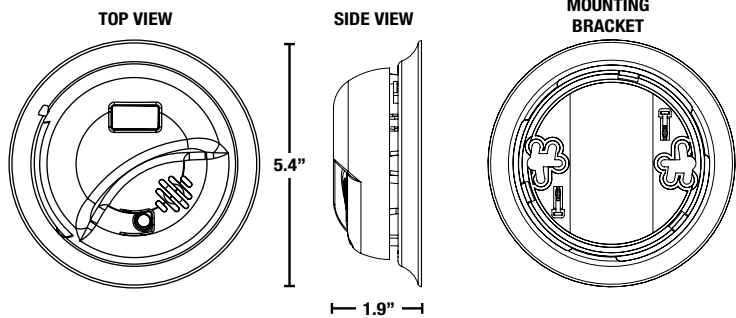

ARCHITECTURAL AND ENGINEERING SPEC

The CO alarm shall be a BRK Model C05120PDBN and shall provide at a minimum the following features and functions:

1. An electrochemical CO sensor with a 10 year service life and an LCD multifunction digital display with peak CO level memory capability.
2. Powered by 120V AC, 60Hz and have a monitored 9V battery backup and a solid state piezo horn rated at 85dB at 10 ft. and be capable of self restoring.
3. The unit shall perform self diagnostic tests and issue a malfunction warning (three chirps) and visually ("Err" in display) if the unit malfunctions.
4. The unit shall have an "End of Life" signal (5 chirps). This signal should be capable of temporarily being silenced for up to 2 days. After about 2 days, the signal will resume. After about 2-3 weeks the signal cannot be silenced.
5. A visual power-on indicator to confirm unit is receiving AC power or has switched to battery backup mode. In battery backup mode, digital display indicates "bAt"; "bAt" indication will flash if battery is weak or missing.
6. The CO sensor is adjusted not to detect CO levels below 30 PPM and will not alarm when exposed to constant levels of 30 PPM for 30 days. It will alarm at the following levels: 400 PPM CO between 4 and 15 minutes, 150 PPM CO between 10 and 50 minutes and 70 PPM CO between 60 and 240 minutes.
7. A test/silence button to check all alarm functions and to silence any nuisance alarms. In addition, the unit shall have a low battery silence feature to quiet the low battery chirp for up to eight hours.
8. A "Smart Interconnect" feature allows the unit to be interconnected to BRK smoke alarms. During a smoke event, the C05120BN horn pattern shall emit the smoke alarm horn pattern (3 beeps, pause, 3 beeps pause). During a CO event, the interconnected CO alarms sound their normal horn pattern.
9. Two Locking features - tamper resistant locking pins that lock battery drawer and/or alarm to mounting bracket.
10. The unit shall be capable of operating between 40°F (4°C) and 100°F (38°C) and relative humidity between 10% and 95%.
11. The unit shall at a minimum meet the requirements of UL2034, CSFM, NFPA 720 and the ICC.

INSTALLATION OF ALARM

Installation of this smoke alarm must conform to all local electrical codes and Article 760 of the National Electrical Code (NFPA 70) and NFPA 72. Interconnected units must meet the following requirements: Total length of wire interconnecting units should be less than 1000 feet, be #18 gauge or larger and be rated at least 300V. It is recommended that all units be on the same fuse or circuit breaker. If local codes do not permit, be sure the neutral wire is common to both phases.

THE PARTS OF THIS SMOKE ALARM

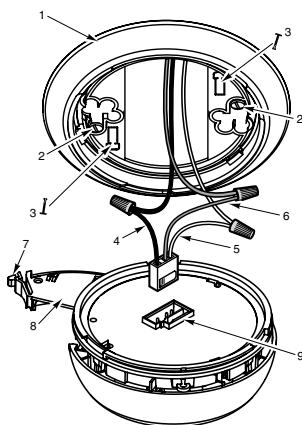

1. Mounting bracket
2. Mounting Slots
3. Locking Pins
4. Hot (Black) AC Wire
5. Neutral (White) AC Wire
6. Interconnect (Orange) Wire
7. Battery Drawer Latch
8. Battery Drawer - Install 9V battery here
9. Quick-Connect Plug

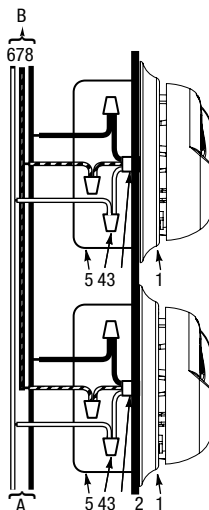

- A. Unswitched 120VAC 60 Hz source
 B. To additional units; Maximum = 18 total (Maximum 12 Smoke Alarms)

1. CO Alarm
2. Ceiling or Wall
3. Power Connector
4. Wire Nut
5. Junction Box
6. Neutral Wire (White)
7. Interconnect Wire (Orange)
8. Hot Wire (Black)

TECHNICAL SPECS

Alarm Dimensions:	5.4" dia. x 1.9"H
Weight:	7.3 oz
Operating Voltage:	120V AC 60Hz w/ 9V alkaline battery backup
Operating Current:	0.09 amps (standby/alarm)
Temperature Range:	40°F (4°C) to 100°F (38°C)
Humidity Range:	10% to 95% relative humidity (RH)
Audio Alarm:	85dB at 10 feet
Test/Silence:	Electronically simulates CO condition, causing the unit to alarm. Press and hold test/silence button.
Alarm Reset:	Automatic when CO clears
Interconnections:	Up to 18 units of First Alert or BRK Smoke, CO and Heat Alarms. Maximum of 12 smoke alarms. See user's manual for details.
CO Sensor:	Electrochemical
Indicator Lights/Sounds:	
AC Power:	Constant Green LED, Display: blank
DC Power:	Intermittent Green LED, Display: "bAt"
Local Alarm:	Red LED flashes rapidly, Display: CO level in PPM
Remote Alarm:	Red LED out. Display: blank
Latching Alarm:	Red LED flashes every 5 seconds after local alarm stops
Listing:	Listed to UL2034 Standards

SHIPPING SPECS

Individual Carton Dimensions	5.54"L x 2.10"W x 5.72"H
Weight	0.61 lbs.
Cube	0.04 ft ³
UPC	0 29054 85619 7
Master Carton Dimensions	13.13"L x 5.81"W x 12.13"H
Master Pack	12
Weight	9.2 lbs.
Cube:	0.54 ft ³
I2of5:	400 29054 85619 5
Pallet Information	
Cases per Layer	25
Number of Layers:	3
Cases per Pallet:	75
Units per Pallet:	900
Cube:	47.3 ft ³
Weight:	758 lbs.



©2014 BRK Brands, Inc. a Jarden Corporation Company (NYSE: JAH)
 3901 Liberty Street Road
 Aurora, IL 60504-8122
 All rights reserved

First Alert is a registered trademark of the First Alert Trust
 BRK is a registered trademark of BRK Brands, Inc.
 CM322