

LED VERSA TUBE

Works with or without a ballast

The LED Versa Tube serves as a special energy efficient replacement for all traditional fluorescent T8 lamps. Designed to operate on all existing rapid-start, programmed-start, and emergency fixture ballasts... or simply **no ballast** at all.

FEATURES

- Works both with or without a ballast
- Works both with shunted or non-shunted sockets
- Fantastic replacement “plug and play” tube or retrofit kit
- Compatible with over 90% of all North American electronic ballasts
- Versatility supports massive projects with different types of ballasts
- Suitable for damp or dry environments
- Minimize labor and recycling costs
- Stable lumen output for different ballast brands with different ballast factors
- UL Type A&B
- Globally patented technology
- 5 Year Manufacturer’s Warranty

WARRANTY

This product has a warranty for a period of 5 years from the date of purchase. The warranty is invalid in the case of improper installation, tampering, or removal of the Q.C. date label. Installation in an improper working environment or installation not according to the current edition of the National Electric Code also invalidates the warranty. Should this product fail during the warranty period, it will be replaced free of charge, subject to correct installation and return of the faulty unit. Greentek Energy Systems does not accept responsibility for any installation costs associated with the replacement of this product. This warranty is in addition to the statutory rights in the country of purchase. Greentek Energy Systems reserves the right to alter specifications without prior notice.

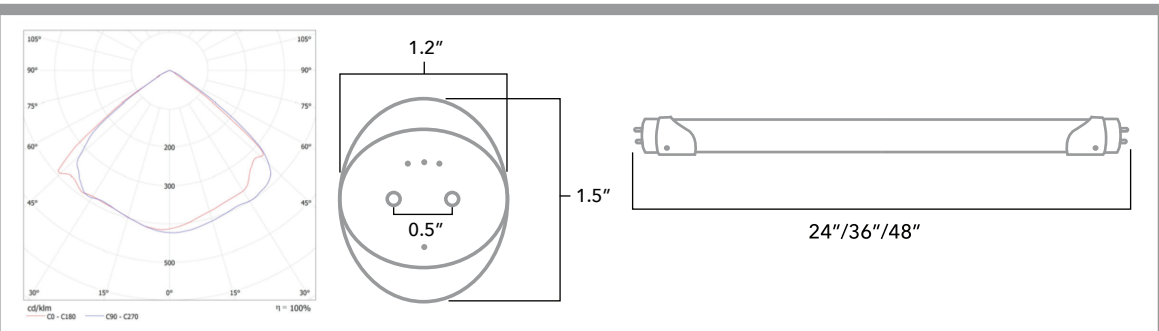

Color Temperature	2700K to 5000K	Operation Temperature	-30°C to 40°C	Input Voltage without ballast	100-277VAC	LED Type	SMT2835
Beam Angle	120 Degrees	Efficiency with ballast	More than 110 LPW	Frequency	50-60Hz	Housing	Aluminum/PC
Color Consistency	4 Steps	Efficiency without ballast	More than 125 LPW	Power Factor	More than 0.99		
CRI	>80	Input Voltage with ballast	100-277VAC, 347 V	Rated Life	50,000 hours		



LED VERSA TUBE

Works with or without a ballast

PRODUCT SPECIFICATIONS

Product Number	Length	Color	Bare Lamp (Watt)	Lumens	Average System Watts (W)			Average System Initial Lumens		
					Low Ballast Factor (0.78)	Norm Ballast Factor (0.88)	High Ballast Factor (1.10)	Low Ballast Factor (1.10)	Norm Ballast Factor (0.88)	High Ballast Factor (1.110)
GT-T8-10W600 BIXX	24"	3500K-5000K	10W	1400	11.5	12.5	13.5	1437	1550	1680
GT-T8-15W600 BIXX	24"	3500K-5000K	15W	2100	16.5	17.5	20.5	2069	2180	2560
GT-T8-15W900 BIXX	36"	3500K-5000K	15W	2100	16.5	17.5	20.5	2069	2180	2560
GT-T8-12W1200 BIXX	48"	3500K-5000K	12W	1680	13.5	16.5	17.5	1680	2069	2180
GT-T8-15W1200 BIXX	48"	3500K-5000K	15W	2100	16.5	17.5	20.5	2069	2180	2560
GT-T8-18W1200 BIXX	48"	3500K-5000K	18W	2520	19.5	21.5	22.5	2430	2680	2810
GT-T8-20W1200 BIXX	48"	3500K-5000K	20W	2700	21.5	22.5	23.5	2687	2805	2935

ORDERING GUIDE

Company Code	Housing Type	Wattage	Length	2835 LED	Internal Driver	Input Type	CCT
GT	T8	12W/15W/18W/20W	20W	XX	I	B	600/900/1200

INSTALLATION INSTRUCTIONS

Direct Replacement Procedure

1. Turn OFF power to the fixture at the breaker panel before installation.
2. Open the diffuser from the light fixture.
3. Remove the fluorescent tubes (A) and dispose of these properly as they may contain mercury.
4. Put LED tube (B) into the lighting fixture and ensure the pins are firmly seated in lamp holders.
5. Install the LED tubes and close the diffuser.
6. Switch ON power to the fixture at the breaker panel.

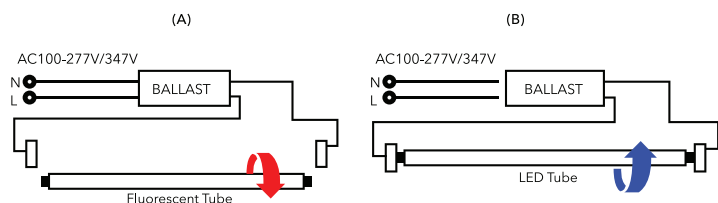

Retrofit Procedure

1. Turn OFF power to the fixture at the breaker panel before installation.
2. Open the diffuser from the light fixture.
3. Remove the fluorescent tubes and dispose of these properly as they may contain mercury.
4. Cut wires and remove (A).
5. Make new wire connection to the branch circuit as shown on diagram (B) below.
6. Replace the cover over the wiring channel.
7. Install the LED tubes and close the diffuser.
8. Switch ON power to the fixture at the breaker panel.

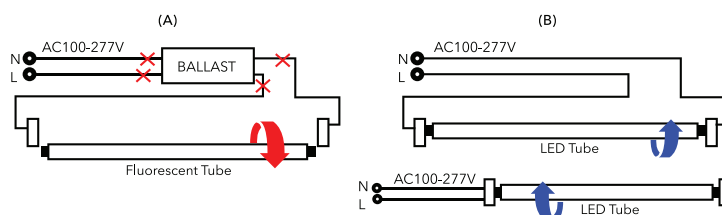

CAUTION

- Risk of fire- do not install this lamp in a pre-heated luminaire.
- Loose or damaged end caps and/or lamp holders need to be replaced before installation.
- Risk of electric shock- make installation with gloves.
- Use only in place of fluorescent lamps specified on label or as a retrofit kit.
- These lamps are not intended for use with emergency exists.
- These lamps are not to be used with a light dimmer.
- If the lamp or luminaire exhibits undesirable operation (i.e. buzzing, flickering, etc.), immediately turn off power and remove the lamp from

luminaire and contact manufacturer.

- This lamp only operates on electronic ballasts. If lamp does not light when the luminaire is energized, remove this lamp from luminaire and contact manufacturer.
- Check the ballast installed in the field and make sure the ballast is in manufacturer's ballast list. If the ballast out of the list, a test must be needed before mass installation.
- Do not make mass installation before sample testing.