

LED 180° CORN BULB

54W

NOTE

- Please turn off power before install or change assembly parts.
- The input voltage and lamps should be matched, after connecting the power line, please make sure the wiring section is insulated
- Make sure to remove or bypass the ballast in the fixtures before installing the lamps.
- Suitable for damp locations. Do not use with dimmers.
- Suitable for use in enclosed luminaires, min lamp compartments dimensions: 340*200*200MM.
- Unprofessional must not install and disassemble the lamps.

WARRANTY

This product has a warranty for a period of 5 years from the date of purchase. The warranty is invalid in the case of improper installation, tampering, or removal of the Q.C. date label. Installation in an improper working environment or installation not according to the current edition of the National Electric Code also invalidates the warranty. Should this product fail during the warranty period, it will be replaced free of charge, subject to correct installation and return of the faulty unit. Greentek Energy Systems does not accept responsibility for any installation costs associated with the replacement of this product. This warranty is in addition to the statutory rights in the country of purchase. Greentek Energy Systems reserves the right to alter specifications without prior notice.

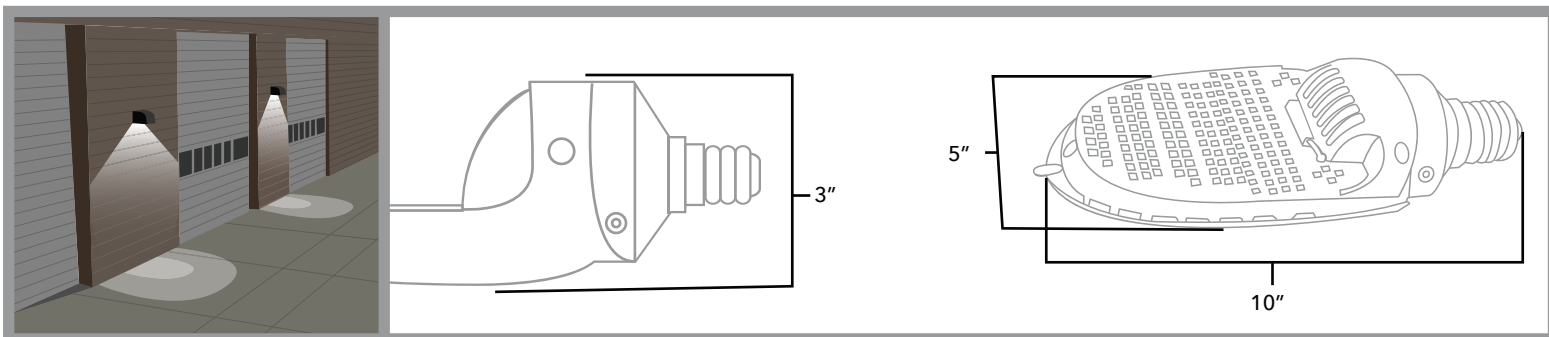

SKU	GT-CBH-54W1A2-Y	Trim	Clear	Input Voltage	AC100-277V
Certification	DLC, UL	Beam Angle (°)	180°	LED Type	SMD 2835
Watts	54W	Lumen	120-130lm/w	Warranty	5 years
Color	5700K	Product Dimensions	10" x 5" x 3"	Lifespan	50,000 hours

LED 180° CORN BULB

54W

Uses:

