

# POST TOP CORN BULB BOTTOM SOCKET

30W

NAME: LED Corn Light

P/N: GT-TCLW-B-30WACA1Z-aaK

Note: 1. The Letter Z in P/N stands for Lamp base type, can be E39, EX39

2. "aa" in P/N stands for CCT, can be 30,35,40,45,50,57.

## APPLICATION

Replacement Lamps for Outdoor Pole/Arm-Mounted Decorative Luminaires (UL Type B)

## ADVANTAGE

- UL DLC certificate.
- E39/EX39 lamp base.
- Warm / Natural / Cool / Cold white.
- 360 degree lighting, high CRI.
- IP64 Waterproof Rating.
- Long lifespan and good heat dissipation, NO fan.
- Meet 3kV surge immunity level.
- Internal driver, input voltage AC100-277V.
- Long lifespan and good heat dissipation.
- Direct replacement for CFL and Metal Halide, Easy Installation.

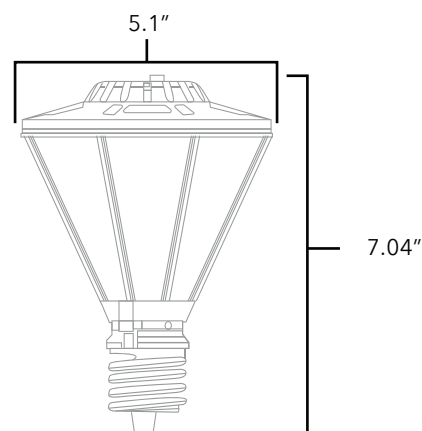
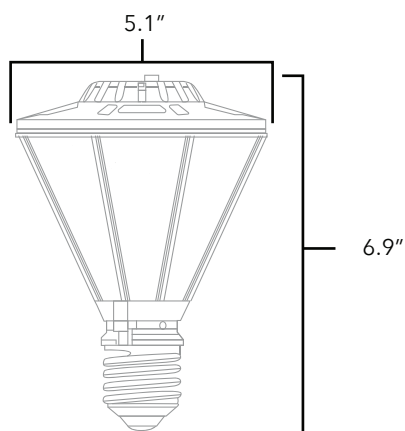

SKU	GT-TCLW-B-30WACA1-E-aaK GT-TCLW-B-30WACA1-EX-aaK	CRI	>80
Lamp Base	E39 EX39	Lumen-In Luminaires	3300~3600 LM
Dimension	Φ 5.1" x 6.9" Φ 5.1" x 7.04"	Lumen Efficacy-In Luminaires	110~120 LM/W
Color temperature	3000K/3500K/4000K/4500K/ 5000K/5700K	Input Power	30 W

# POST TOP CORN BULB BOTTOM SOCKET

30W

Viewing Angle	360 degree	Waterproof Rating	IP64
Input Voltage	AC100-277V 50/60Hz	LED Type	SMD2835
PF	≥0.9	LED QTY	144 PCS
Equivalent	60W CFL	Housing	PC + AL
Storage Humidity	10%-75% RH	Housing color	White
Application	Indoor / Outdoor	Operating Temperature	-20°C TO 45°C
Safety Certification	UL DLC	Operating Humidity	20%-70% RH
Warranty Time	5 Years	Storage Temperature	-30°C TO 80°C

## LIGHT DISTRIBUTION TESTING PARAMETERS

### LUMINAIRE PROPERTY

Voltage	120.0V
Power	31.6
Current	0.2719 A
Power Factor	0.9685

### WARRANTY

This product has a warranty for a period of 5 years from the date of purchase. The warranty is invalid in the case of improper installation, tampering, or removal of the Q.C. date label. Installation in an improper working environment or installation not according to the current edition of the National Electric Code also invalidates the warranty. Should this product fail during the warranty period, it will be replaced free of charge, subject to correct installation and return of the faulty unit. Greentek Energy Systems does not accept responsibility for any installation costs associated with the replacement of this product. This warranty is in addition to the statutory rights in the country of purchase. Greentek Energy Systems reserves the right to alter specifications without prior notice.

## LIGHT DISTRIBUTION TESTING PARAMETERS

### PHOTOMETRIC RESULTS

IES Classification	Type IV
Total Rated Lamp Lumens	3688lm
Efficiency	100%
Upward Ratio	21%
Central Intensity	32.95 cd
Pos. of Max Intensity	H337.5 V57
Longitudinal Classification	Short
Measurement Flux	3688lm
Downward Ratio	79%
Luminaire Efficiency Rating (LER)	116.71
Max Intensity	830.19 cd



# POST TOP CORN BULB BOTTOM SOCKET

30W

## LUMINOUS INTENSITY DISTRIBUTION DIAGRAM

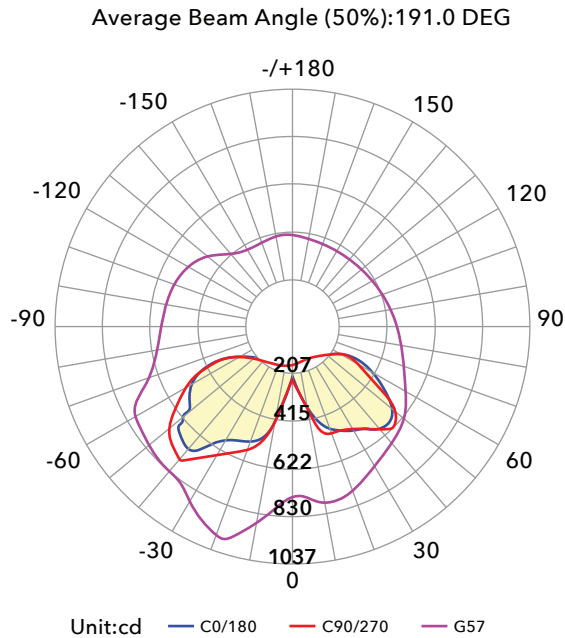

## THE AVERAGE ILLUMINANCE EFFECTIVE FIGURE

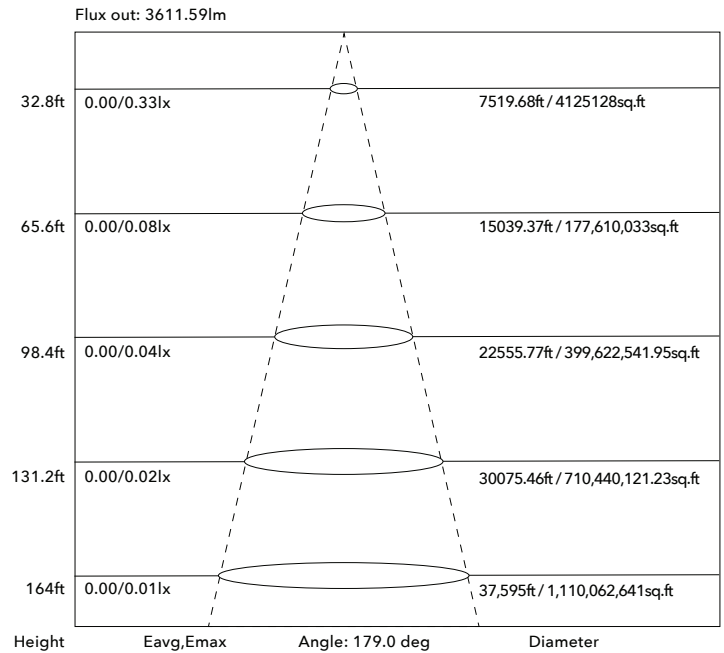

Note: The Curves indicate the illuminated area and the average illumination when the luminaire is at different distance.

## PACKAGING

	Size	Qty/Carton	Net Weight/Carton	Gross Weight / Carton
Inner Box	9.4" x 7.0" x 7.0"	1 PC	1.3 LBS	1.69 LBS
Outer Box	22.04" x 10.0" x 15.15"	6 PCS	7.7 LBS	12.34 LBS

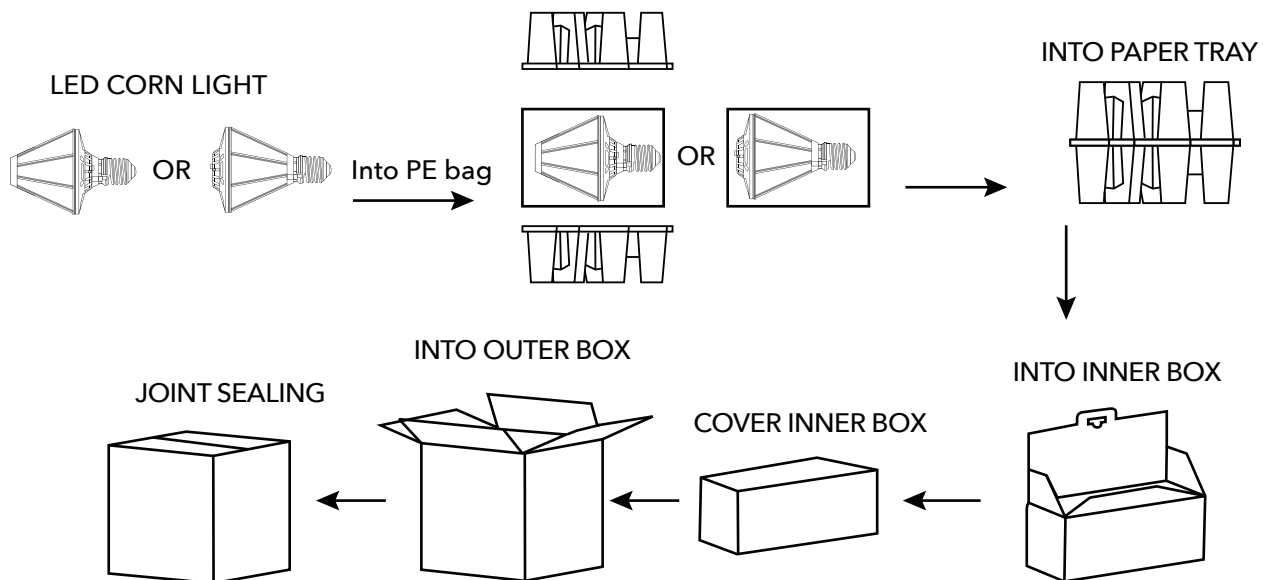

# POST TOP CORN BULB BOTTOM SOCKET

30W

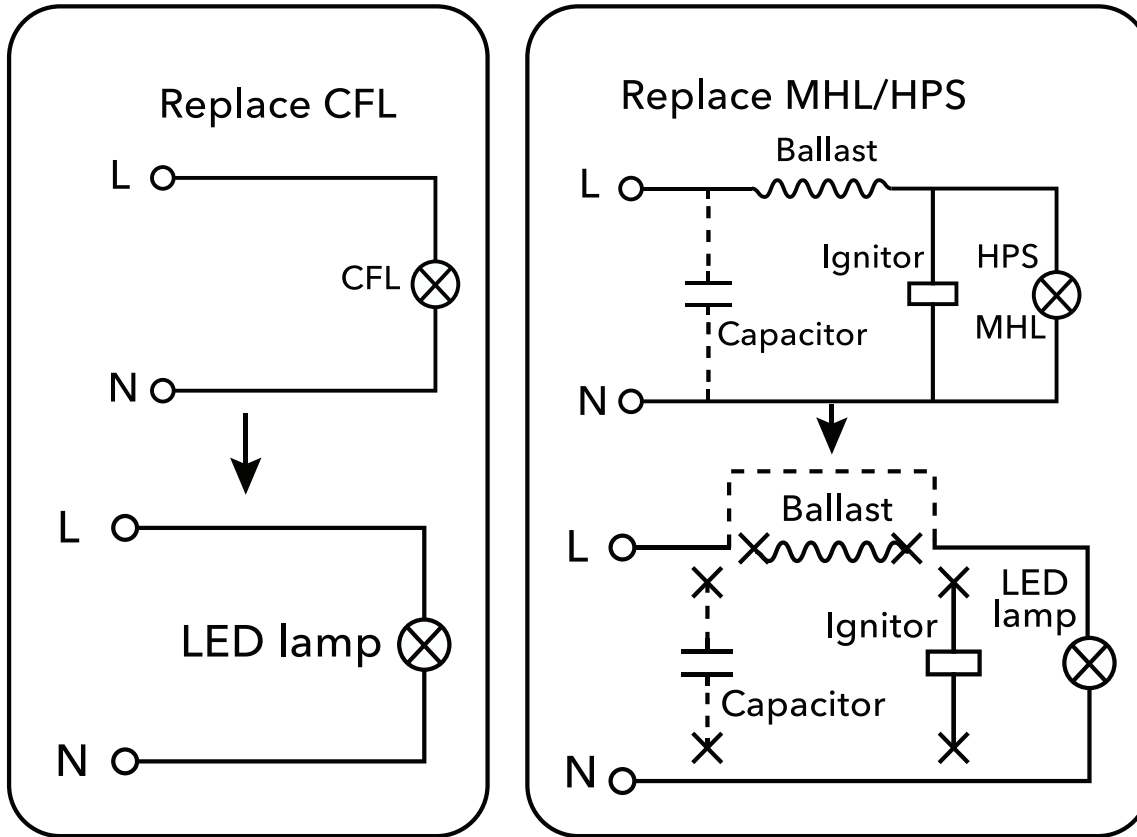

## CAUTION

- Please turn off power before install or change assembly parts.
- The input voltage and lamps should be matched, after connecting the power line, please make sure the wiring section is insulated.
- Make sure to remove or bypass the ballast in the fixtures before install the lamps.
- Suitable for damp locations. Do not use with dimmers.
- Suitable for use in enclosed luminaires, min. lamp compartment dimensions: 13.38" x 7.87" x 7.87"
- No-professionals, must not install and disassemble the lamps.

## TROUBLESHOOTING

Troubles	Check points
Flickering of the light	Turn off the power and turn on again in 3 minutes. If same phenomena occur, then call agencies
Out of working	Please check the connection

