

NAME: LED Corn Light

P/N: GT-TCLW-T-30WACA1Z-aaK

Note: 1. The Letter Z in P/N stands for Lamp base type, Can be E39 ,EX39
2. "aa" in P/N stands for CCT, can be 30,35,40,45,50,57.

Advantage :

- UL DLC certificate.
- E39/EX39 lamp base.
- Warm / Natural / Cool / Cold white.
- 360 degree lighting, high CRI.
- IP64 Waterproof Rating.
- Long lifespan and good heat dissipation, NO fan.
- Meet 3kV surge immunity level.
- Internal driver, input voltage AC100-277V.
- Long lifespan and good heat dissipation.
- Direct replacement for CFL and Metal Halide, Easy Installation.

Application :

- ◆ Replacement Lamps for Outdoor Pole/Arm-Mounted Decorative Luminaires (UL Type B)

TECHNICAL DATA SHEET

Product Specifications

Product name	LED Corn Light	
Part No	GT-TCLW-T-30WACA1-E-aaK	GT-TCLW-T-30WACA1-EX-aaK
Lamp Base	E39	EX39
Dimension	Φ130*177 MM	Φ130*179 MM

Technical Characteristic

Color temperature	3000K/3500K/4000K/4500K/5000K/5700K
CRI	>80
Lumen-In Luminaires	3300~3600 LM
Lumen Efficacy-In Luminaires	110~120 LM/W
Input Power	30 W
Viewing Angle	360 degree
Input Voltage	AC100-277V 50/60Hz
PF	≥0.9
Equivalent	60W CFL
Waterproof Rating	IP64

Materials

LED Type	SMD2835
LED QTY	144 PCS
Housing	PC + AL
Housing color	White

Others

Operating Temperature	-20℃ TO 45℃
Operating Humidity	20%-70% RH
Storage Temperature	-30℃ TO 80℃
Storage Humidity	10%-75% RH
Application	Indoor / Outdoor
Safety Certification	UL DLC
Warranty Time	5 Years

Light Distribution Testing Parameters

Remark: The testing data comes from the product in luminaires.

Luminaire Property

Luminaire Manufacturer:

Voltage: 119.9 V

Power: 31.5 W

Current: 0.2706 A

Power Factor: 0.9702

Photometric Results

IES Classification: Type I

Total Rated Lamp Lumens: 3618.9 lm

Efficiency: 100%

Upward Ratio: 35%

Central Intensity: 40.89 cd

Pos of Max. Intensity: H22.5 V70

Longitudinal Classification: Medium

Measurement Flux: 3618.9 lm

Downward Ratio: 65%

Luminaire Efficacy Rating (LER): 114.89

Max. Intensity: 687.44 cd

Luminous Intensity Distribution Curve

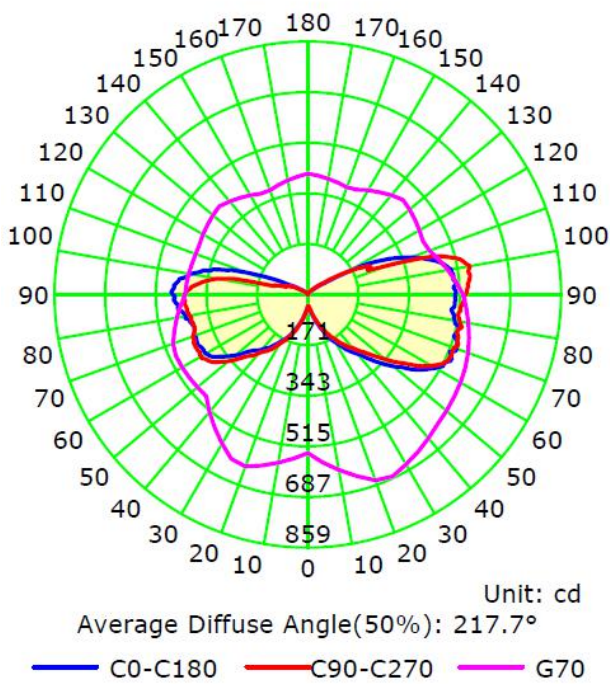

The Average Illuminance Effective Figure

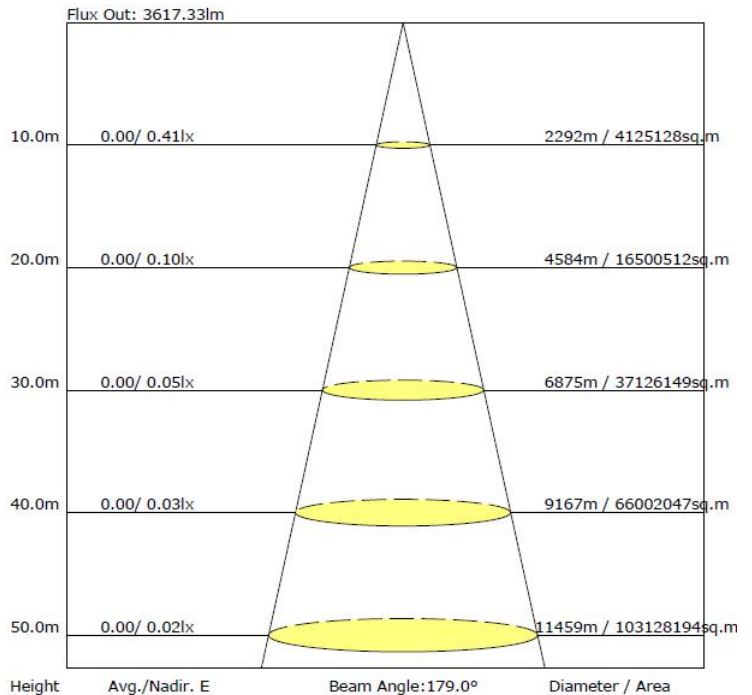

TECHNICAL DATA SHEET

Package

	Size	Qty / Carton	Net Weight / Carton	Gross Weight / Carton
Inner box	240*180*180 MM	1 PC	0.59 KG	0.77 KG
Outer box	560*255*385 MM	6 PCS	3.5 KG	5.6 KG

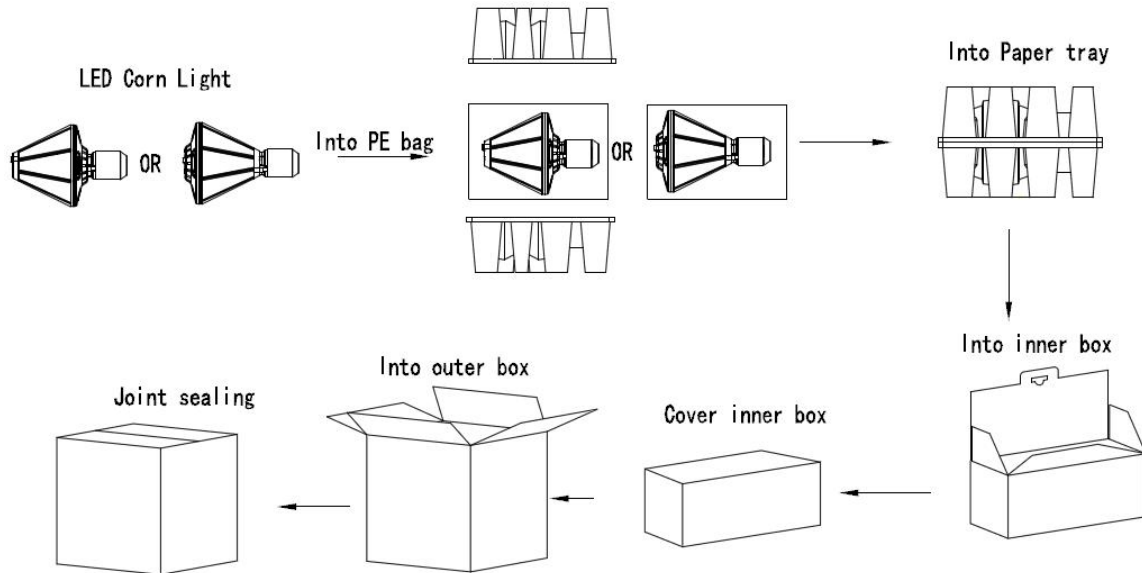

Notice For User

- ◆ Please turn off power before install or change assembly parts.
- ◆ The input voltage and lamps should be matched, after connecting the power line, please make sure the wiring section is insulated.
- ◆ Make sure to remove or bypass the ballast in the fixtures before install the lamps.
- ◆ Suitable for damp locations. Do not use with dimmers.
- ◆ Suitable for use in enclosed luminaires, min. lamp compartment dimensions: 340*200*200 MM.
- ◆ No-professionals, must not install and disassemble the lamps.

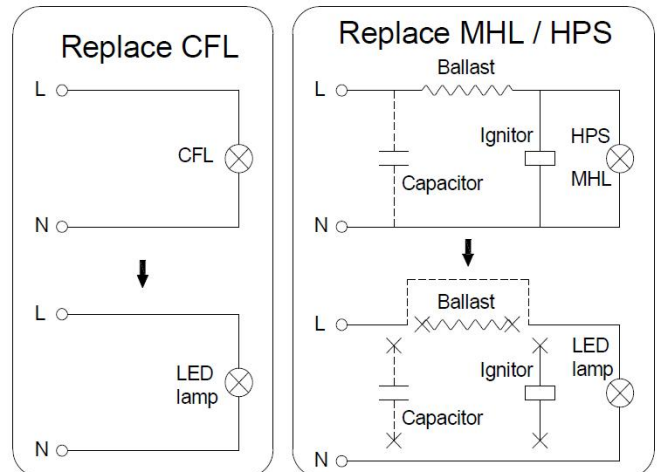

Trouble Shootings

Troubles	Check points
Flickering of the light	Turn off the power and turn on again in 3 minutes. If same phenomena occur, then call agencies.
Out of working	Please check the connection.