



GREENTEK ENERGY SYSTEMS, LLC
www.greentekes.com



NAME: LED SPORT LIGHT

P/N: GT-SP2-1200W-DLdcJS3-agf-W

Note:

GT=Company name;

SP2 = Product series;

1200W= Rating Power;

DL=AC120-277V driver;

d=surge protection situation,can be 10SP,20SP or blank;

c=Photocell situation,can be any letters or blank;

J= manufacturer of LED;

S3=30degree diffuser Light Angle type;

a= lamp colors;

g=CCT,such as 40K=4000K, 50K=5000K,57K=5700K.

f=mounting bracket types, can be FM,AM or blank;

W=Dimming Module provided.

DIMENSIONS

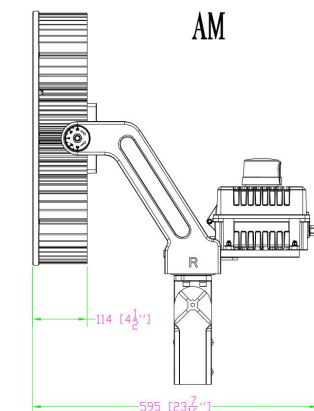
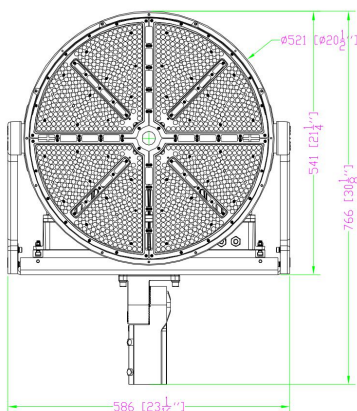
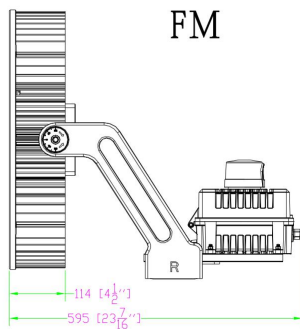
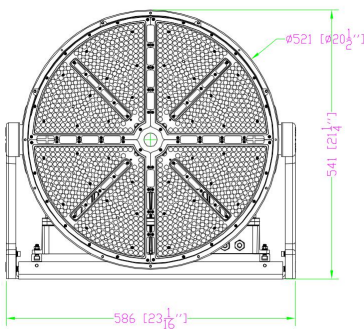

ADVANTAGE

- UL DLC-V5.1(Premium) certificate
- Wattage adjustable
- Input voltage 120-277Vac
- No UV or IR in the beam
- Easy to install and operate
- Energy saving, long lifespan
- Instant start, NO flickering, NO humming
- Green and eco-friendly without mercury
- Output constant current lever can be adjusted through output cable with 0-10V.

APPLICATION

- ◆ Gymnasium;
- ◆ Square plaza;
- ◆ Shipyard, Airport ,wharf;
- ◆ High mast and Contour lighting, etc.

SPECIFICATIONS

OPTICAL	Input Power (Tolerance : ±10%)	1200W (Wattage adjustable:800W-1000W-1200W)		
	Color Temperature	4000K	5000K	5700K
	Lumen (Tolerance : -10%)	168000 LM	170400 LM	171600 LM
	Efficacy (Tolerance : -3%)	140 LM/W	142LM/W	143 LM/W
	CRI	>70		
	Color Consistency	<6 Steps (or <6 SDCM)		
	BUG	B5-U0-G5		
	Distribution Pattern	NEMA:4		
	Beam Angle (50%) (Tolerance : ±15%)	30°		
ELECTRICAL	Input Voltage and Frequency	120-277VAC, 50/60Hz		
	PF (Tolerance : -3%)	≥0.9		
	THD (Tolerance : +5%)	≤20%		
	Flicker Percent	<5%		
	Driver Brand	uPowerTek		
	Driver Model	BLD-600-C420-ENU*2PCS		
	Driver Surge protection	L/N-PE: 10kV, L-N:6kV		
	Dimming	0-10V dimming standard		
	Sensor Type	Integral Sensor Receptacle		
	Optional Accessory	Sensor Receptacle+Photosensor /Sensor Receptacle+Short Cap , Surge-protective Device		
MATERIALS	LED Brand	Bridgelux		
	LED Type	SMD3030		
	LED QTY	1232 PCS		
	Housing	Die-cast aluminum		
	Housing Color	Black, Bronze, or Customized		
	EPA	3.4 ft ²		
	Waterproof Rating	WET (IP65)		
OTHERS	Operating Temperature	-40°C TO 45°C		
	Storage Temperature	-40°C TO 80°C		
	Operating Humidity	20% - 90% RH		
	Storage Humidity	10% - 95% RH		
	Warranty	5 years		

PACKAGE

Lamp Net Weight: 28.1 KG / PC

	Size	Qty / Carton	Gross Weight / Carton
Outer box	600*585*395mm	1 PC	33.83 KG

Tolerance of Carton Size: ±15 MM, Tolerance of Weight: ±10%.

LIGHT DISTRIBUTION TESTING PARAMETERS < 30° >

Luminaire Property

Luminaire Manufacturer:
 Luminaire Category:
 Lamp Catalog:
 Number of Lamps:
 Luminous Length (mm):
 Luminous Height (mm):
 Current: 10.787 A
 Power Factor: 0.996

Luminaire Description:
 Lamp Description:
 Lumens per Lamp:
 Luminous Width (mm):
 Voltage: 120.0 V
 Power: 1289.21 W

Photometric Results

IES Classification: Type I
 Total Rated Lamp Lumens: 180519.5 lm
 Efficiency: 100%
 Upward Ratio: 0%
 C0r0 Intensity: 493505.81 cd
 Pos of Max. Intensity: H0 V1
 Beam Angle(C0/C180,C90/C270,C45/C225,C135/315): 29.1, 29.2, 29.2, 29.0

Longitudinal Classification: Very Short
 Measurement Flux: 180519.5 lm
 Downward Ratio: 100%
 Luminaire Efficacy Rating (LER): 140.07
 Max. Intensity: 495426.04 cd

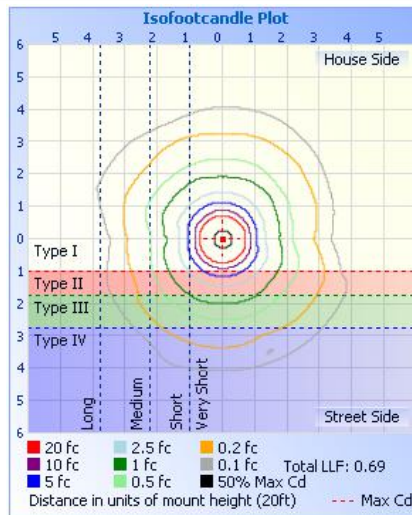
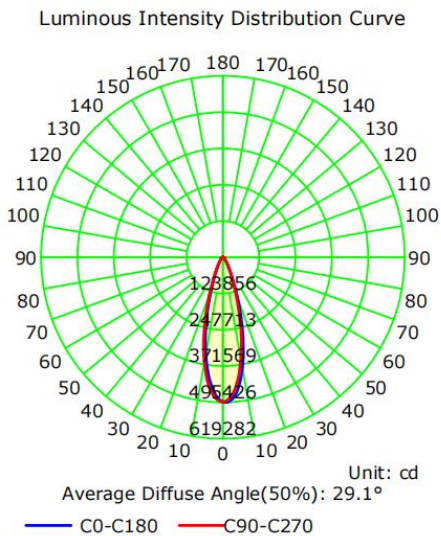

NOTICE FOR USER

- Please turn off power before install or change assembly parts.
- The input voltage and lamps should be matched, after connecting the power line, Please make sure the wiring section is insulated.
- No-professionals, must not install and disassemble the lamps.

TROUBLE SHOOTINGS

Troubles	Check points
Flickering of the light	Turn off the power and turn on again in 3 minutes. If same phenomena occur, then call agencies.
Out of working	Please check the connection.