

LED PARKING GARAGE LIGHT

55W

P/N: GT-PG02-55WAANA1-57K

Note: GT= Company name

PG02 = Product series, LED Parking Garage Light

55W = Rating Power, 55W

The first A = Hongli 2835

The second A = Diffuser cover type, A represent Stripe PC cover

N = The lens have no reflector

A1 = Version number

57K=5700K

ADVANTAGES

- UL cUL certificate
- IP65 Internal driver, Input voltage 100-277Vac.
- Output constant current lever can be adjusted through output cable with 0-10V.
- No UV or IR in the beam.
- Easy to install and operate.
- Energy saving, Long lifespan.
- Light is soft and uniform, Safe to eyes.
- Instant start, NO flickering, NO humming.
- Green and eco-friendly without mercury.

APPLICATION

- Widely used in underground parking lot garages

WARRANTY

This product has a warranty for a period of 5 years from the date of purchase. The warranty is invalid in the case of improper installation, tampering, or removal of the Q.C. date label. Installation in an improper working environment or installation not according to the current edition of the National Electric Code also invalidates the warranty. Should this product fail during the warranty period, it will be replaced free of charge, subject to correct installation and return of the faulty unit. Greentek Energy Systems does not accept responsibility for any installation costs associated with the replacement of this product. This warranty is in addition to the statutory rights in the country of purchase. Greentek Energy Systems reserves the right to alter specifications without prior notice.

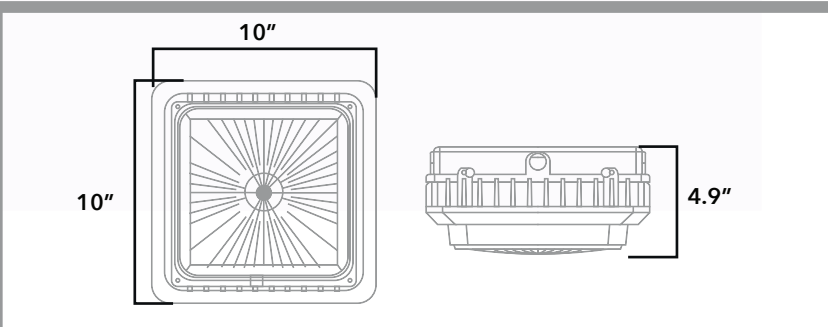

Input Power	55W	CRI	>80	THD	≤20%
Lumen	6900-7450 LM	Viewing Angle	160°	Driver Brand	China Brand Driver
Lumen Efficacy	127-133 LM/W	Input Voltage	100-277VAC 50/60Hz	Optional Accessory	Motion sensor, Surge Protective Device
Color Temperature	5700K	PF	≥0.9	LED Type	SMD2835 (0.5W)

LED PARKING GARAGE LIGHT

55W

LED QTY	165 PCS	Waterproof Rating	WET (IP65)	Storage Humidity	10%-95% RH
Housing	Aluminum + PC	Operating Temperature	-4°F TO 113°F	Warranty Time	5 Years
Housing Color	White	Operating Humidity	20%-90% RH		
Cover	Stripe PC Cover	Storage Temperature	-22°F TO 176°F		

PACKAGING Lamp Net Weight: 4.1LBS /PC

	Size	Qty/Carton	Gross Weight / Carton
Inner box	11" x 10.6" x 6.8"	1 PC	5LBS
Outer box	22" x 14.5" x 11.8"	4 PCS	23.3LBS

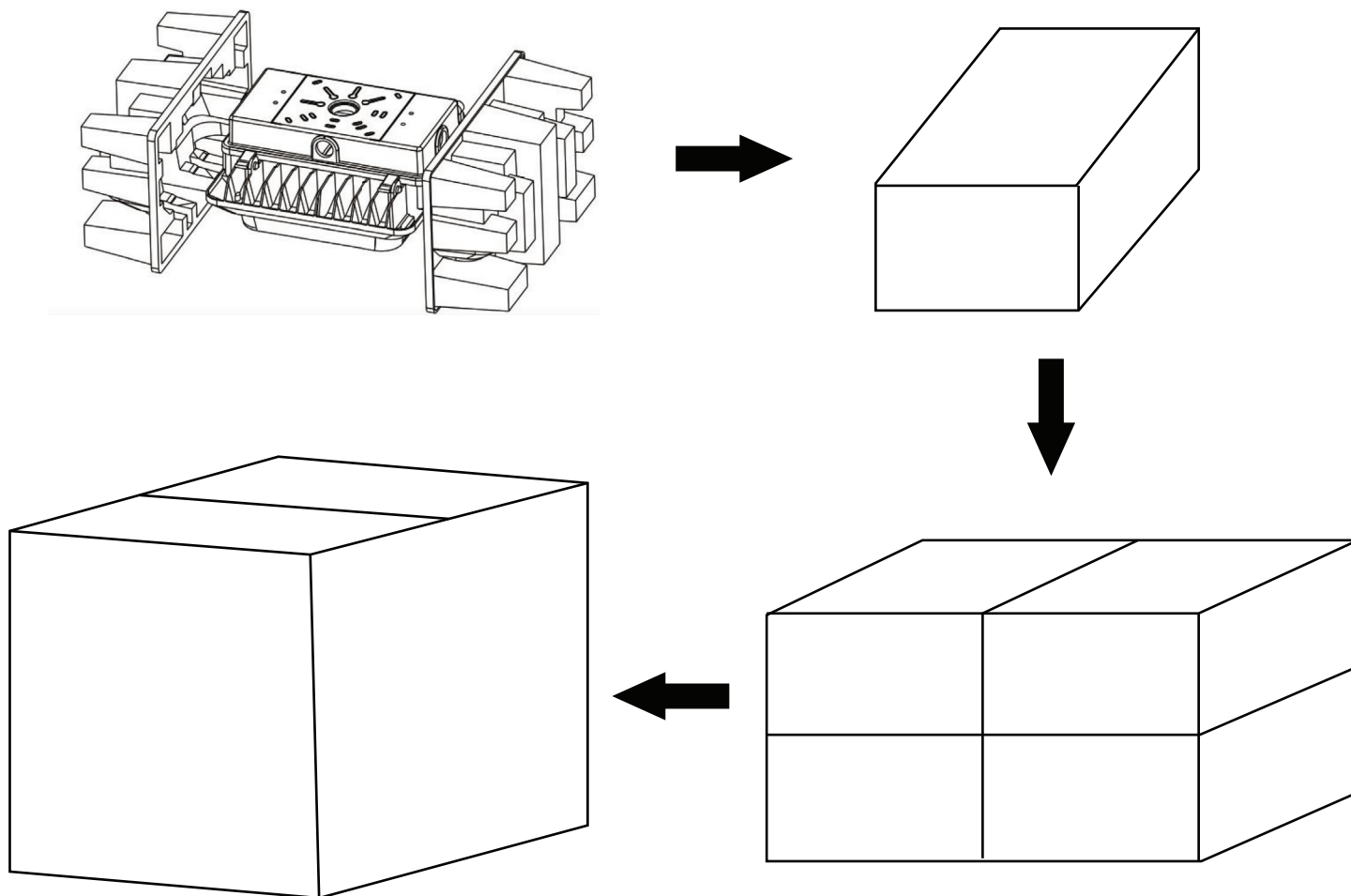

LED PARKING GARAGE LIGHT

55W

LUMINOUS INTENSITY DISTRIBUTION DIAGRAM

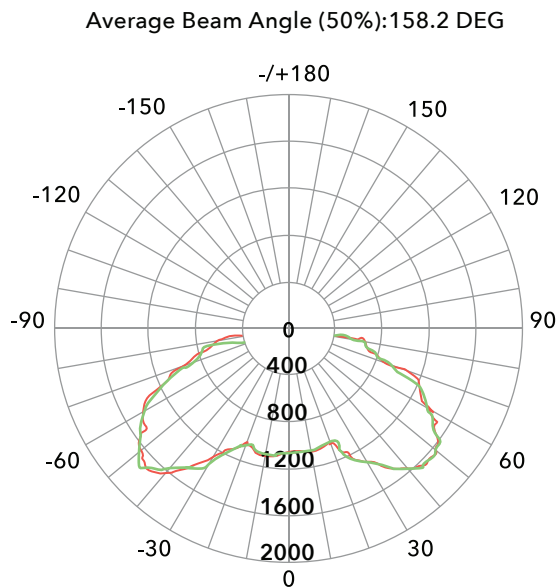

Unit:cd
 — C0/180, 78.9, 79.3
 — C90/270, 78.5, 79.6

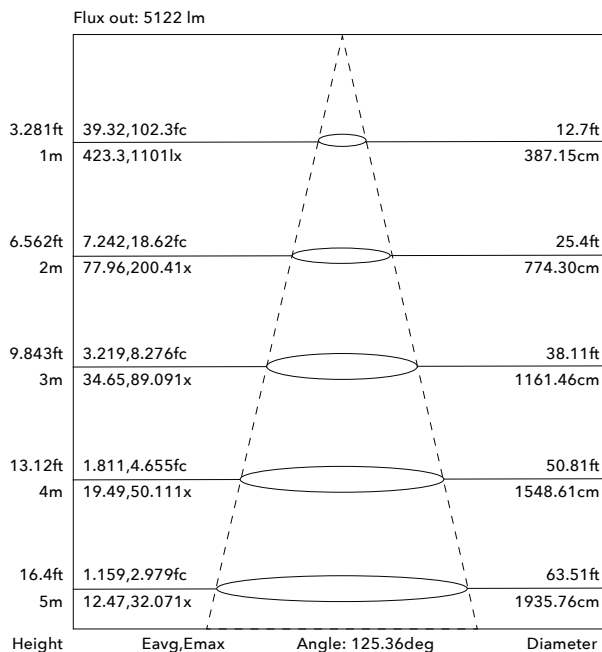

Note: The Curves indicate the illuminated area and the average illumination when the luminaire is at different distance.

LIGHT DISTRIBUTION TESTING PARAMETERS

Data of Lamp		Photometric Data			Eff: 131.15 lm/W
Model		Imax (cd)	1838	S/MH (C0/180)	2.09
Nominal Power (W)	55	LOR (%)	100.0	S/MH (C90/270)	2.09
Rated Voltage (V)	120	Total Flux (lm)	7305.2	η UP, DN (CO-180)	1.9, 48.4
Nominal Flux (1m)	7305.18	CIE Class	Direct	η UP, DN (C180-360)	1.8, 47.9
Lamps Inside	1	η up (%)	3.7	CIBSE SHR NOM	2.00
Test Voltage	120.0	η down (%)	96.3	CIBSE SHR MAX	0.00

CAUTION

- Please turn off power before install or change assembly parts.
- The input voltage and lamps should be matched, after connecting the power line, Please make sure the wiring section is insulated.
- No-professionals, must not install and disassemble the lamps.

TROUBLESHOOTING

Troubles	Check points
Flickering of the light	Turn off the power and turn on again in 3 minutes. If same phenomena occur, then call agencies
Out of working	Please check the connection