



GREENTEK ENERGY SYSTEMS, LLC
www.GreentekEnergySystems.com



P/N: GT-PG02-55WASA2-dK-abce

Note:

“a” can be any two letters to represent lamp colors:
WH=White, BR=Brown, or Customized;
“b” can be S or blank;
represent Surge protector or None Surge protector;
“c” can be M or blank;
represent Motion-sensor or None motion-sensor;
“dK” can be any two digits to represent CCT, can be
30K=3000K, 35K=3500K, 40K=4000K,
45K=4500K, 50K=5000K, 57K=5700K, 65K=6500K.
“e” can be “EM” or blank
represent Emergency power supply

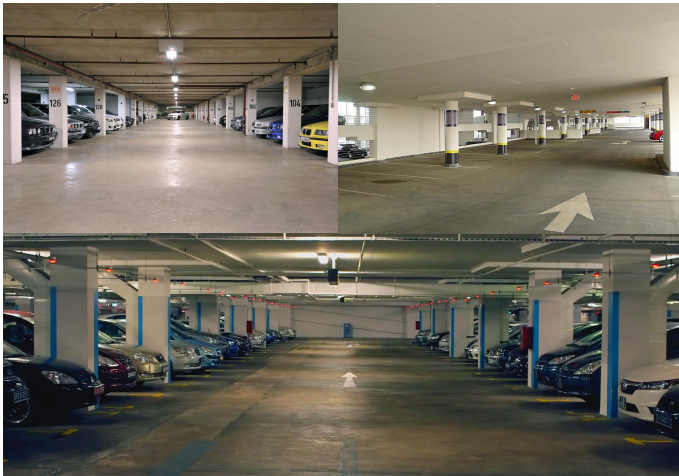

DIMENSIONS

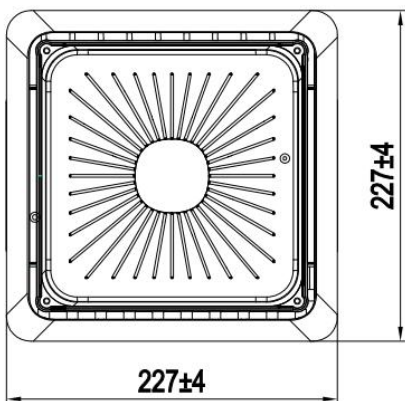
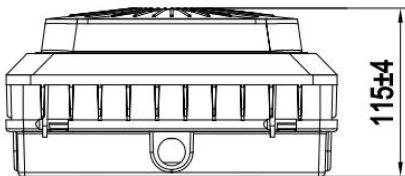

ADVANTAGE

- UL cUL DLC-V5.1(Premium) certificate.
- IP65 Internal driver, Input voltage 120-277Vac.
- Output constant current lever can be adjusted through output cable with 0-10V.
- No UV or IR in the beam.
- Easy to install and operate.
- Energy saving, Long lifespan.
- Light is soft and uniform, Safe to eyes.
- Instant start, NO flickering, NO humming.
- Green and eco-friendly without mercury.

APPLICATION

- Widely used in underground parking lot, garage and so on..

SPECIFICATIONS

| | | |
|-------------------|--|---|
| OPTICAL | Input Power (Tolerance : ±10%) | 55W |
| | Color Temperature | 3000K 3500K 4000K 4500K 5000K 5700K 6500K |
| | Lumen (Tolerance : -10%) | 6987LM 7001LM 7014LM 7027LM 7040LM 7054LM 7080LM |
| | Efficacy (Tolerance : -3%) | 132LM/W 132LM/W 132LM/W 133LM/W 133LM/W 134LM/W 134LM/W |
| | CRI | >80 |
| | Color Consistency | <6 Steps (or <6 SDCM) |
| | BUG | B2-U3-G2 |
| | Diffuser Type | Clear Stripe PC |
| ELECTRICAL | Beam Angle (50%) (Tolerance : ±15%) | 150 Degree |
| | Input Voltage and Frequency | 120-277VAC, 50/60Hz; |
| | PF (Tolerance : -3%) | ≥0.9 |
| | THD (Tolerance : +5%) | ≤20% |
| | Flicker Percent | <60% |
| | Driver Brand | Daermay |
| | Driver Model | HB-LPG060-52 |
| | Driver Surge protection | L/N-PE: 4kV, L-N: 4kV |
| MATERIALS | Dimming | 0-10V dimming standard |
| | LED Brand | HongLi |
| | LED Type | SMD2835 (0.5W) |
| | LED QTY | 165 PCS |
| | Housing | Die-cast aluminum |
| | Housing Color | White, or Customized |
| OTHERS | Waterproof Rating | WET (IP65) |
| | Operating Temperature | -40°C TO +45°C |
| | Storage Temperature | -40°C TO 80°C |
| | Operating Humidity | 20% - 90% RH |
| | Storage Humidity | 10%-95% RH |
| Warranty | 5 years warranty with 24/7 operating hours Luminaire lifetime at 25°C. | |

PACKAGE

| | Size | Qty/ Carton | Lamps Net Weight | Weight/ Carton |
|-----------|----------------|-------------|------------------|----------------|
| Inner box | 280*270*175 MM | 1 PC | 1.9KG | 2.4KG |
| Outer box | 560*370*300 MM | 4 PCS | 7.6KG | 9.6KG |

Tolerance of Carton Size: ±15 MM, Tolerance of Weight: ±10%.

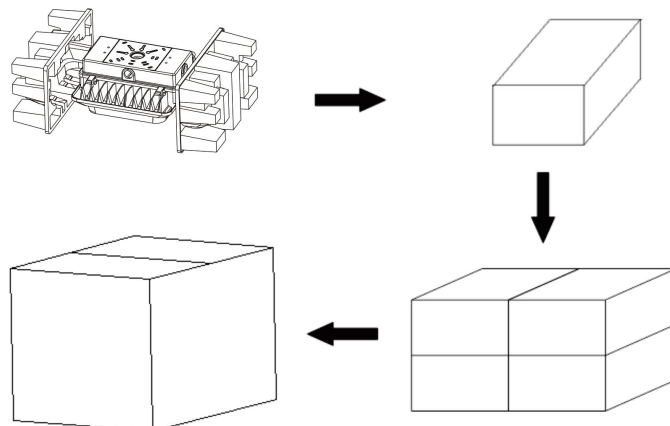

LIGHT DISTRIBUTION TESTING PARAMETERS

Luminaire Property

Luminaire Manufacturer:
 Luminaire Category:
 Lamp Catalog:
 Number of Lamps:
 Luminous Length (mm):
 Luminous Height (mm):
 Current: 0.460 A
 Power Factor: 0.985

Luminaire Description:
 Lamp Description:
 Lumens per Lamp:
 Luminous Width (mm):
 Voltage: 120.0 V
 Power: 54.36 W

Photometric Results

CIE Class: Direct
 Measurement Flux: 6841.1 lm
 Downward Ratio: 97%
 Field Angle(C0/C180,C90/C270,C45/C225,C135/315): 170.7, 170.7, 172.6, 172.5
 Beam Angle(C0/C180,C90/C270,C45/C225,C135/315): 143.0, 143.1, 143.1, 143.5
 Luminaire Efficacy Rating (LER): 125.90
 Max. Intensity: 1732.77 cd
 S/MH(C0/C180): 2.14

Total Rated Lamp Lumens: 6841.1 lm
 Efficiency: 100%
 Upward Ratio: 3%
 C0r0 Intensity: 997.31 cd
 Pos of Max. Intensity: H225 V57
 S/MH(C90/C270): 2.16

Luminous Intensity Distribution Curve

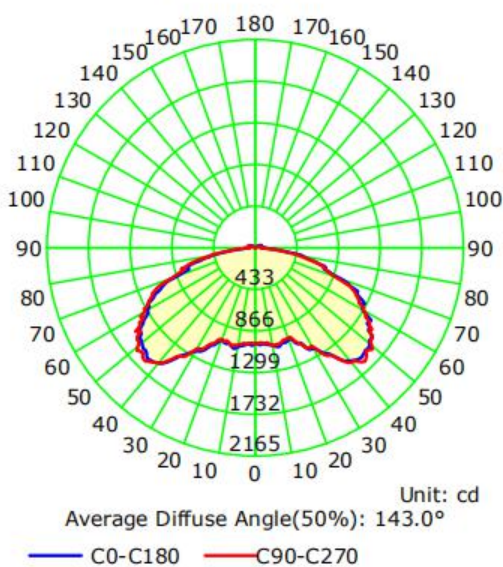

The Average Illuminance Effective Figure

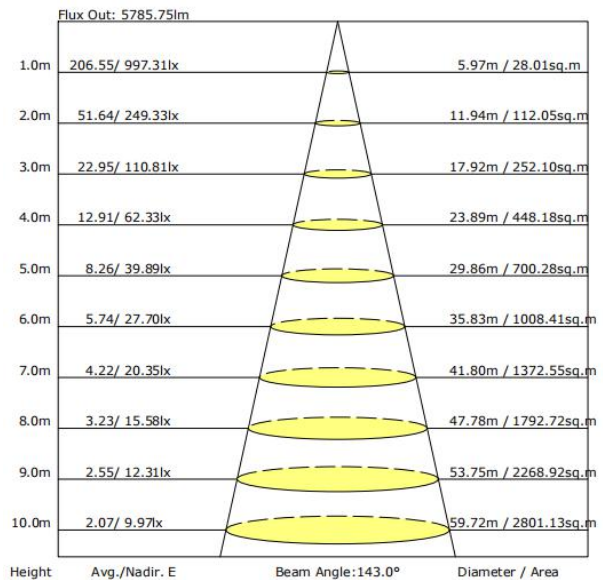

NOTICE FOR USER

- Please turn off power before install or change assembly parts.
- The input voltage and lamps should be matched, after connecting the power line, Please make sure the wiring section is insulated.
- No-professionals, must not install and disassemble the lamps.

TROUBLE SHOOTINGS

| Troubles | Check points |
|-------------------------|--|
| Flickering of the light | Turn off the power and turn on again in 3 minutes. If same phenomena occur, then call agencies. |
| Out of working | Please check the connection. |