



**GREENTEK ENERGY SYSTEMS, LLC**  
[www.GreentekEnergySystems.com](http://www.GreentekEnergySystems.com)



**P/N: GT-PG02-100WASA2-dK-abc**

Note:

“a” can be any two letters to represent lamp colors:  
WH=White, BR=Brown, or Customized;  
“b” can be S or blank;  
represent Surge protector or None Surge protector;  
“c” can be M or blank;  
represent Motion-sensor or None motion-sensor;  
“dK” can be any two digits to represent CCT, can be  
30K=3000K, 35K=3500K, 40K=4000K,  
45K=4500K, 50K=5000K, 57K=5700K, 65K=6500K.

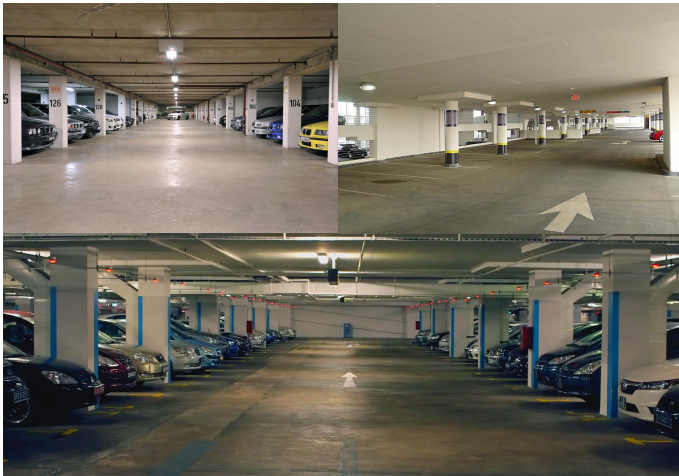

## DIMENSIONS

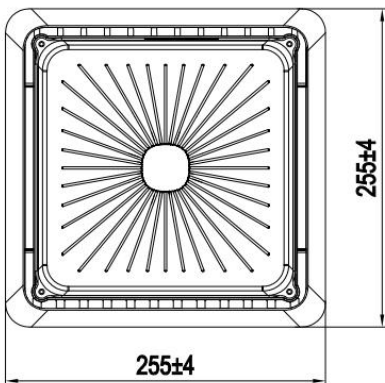
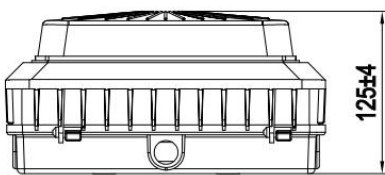

## ADVANTAGE

- UL cUL DLC-V5.1(Premium) certificate.
- IP65 Internal driver, Input voltage 120-277Vac.
- Output constant current lever can be adjusted through output cable with 0-10V.
- No UV or IR in the beam.
- Easy to install and operate.
- Energy saving, Long lifespan.
- Light is soft and uniform, Safe to eyes.
- Instant start, NO flickering, NO humming.
- Green and eco-friendly without mercury.

## APPLICATION

- Widely used in underground parking lot, garage and so on..

## SPECIFICATIONS

<b>OPTICAL</b>	Input Power (Tolerance : ±10%)	100W						
	Color Temperature	3000K	3500K	4000K	4500K	5000K	5700K	6500K
	Lumen (Tolerance : -10%)	13312LM	13399LM	13487LM	13574LM	13662LM	13749LM	13924LM
	Efficacy (Tolerance : -3%)	130LM/W	131LM/W	132LM/W	133LM/W	135LM/W	136LM/W	138LM/W
	CRI	>80						
	Color Consistency	<6 Steps (or <6 SDCM)						
	BUG	B3-U3-G3						
	Diffuser Type	Clear Stripe PC						
	Beam Angle (50%) (Tolerance : ±15%)	150 Degree						
<b>ELECTRICAL</b>	Input Voltage and Frequency	120-277VAC, 50/60Hz;						
	PF (Tolerance : -3%)	≥0.9						
	THD (Tolerance : +5%)	≤20%						
	Flicker Percent	<60%						
	Driver Brand	Daermay						
	Driver Model	MP-100T130A						
	Driver Surge protection	L/N-PE: 6kV, L-N: 6kV						
	Dimming	0-10V dimming standard						
<b>MATERIALS</b>	LED Brand	HongLi						
	LED Type	SMD2835 (1W)						
	LED QTY	140 PCS						
	Housing	Die-cast aluminum						
	Housing Color	White, or Customized						
	Waterproof Rating	WET (IP65)						
<b>OTHERS</b>	Operating Temperature	-30°C TO +45°C						
	Storage Temperature	-40°C TO 80°C						
	Operating Humidity	20% - 90% RH						
	Storage Humidity	10%-95% RH						
	Warranty	5 years warranty with 24/7 operating hours Luminaire lifetime at 25°C.						

## PACKAGE

	Size	Qty/ Carton	Lamps Net Weight	Weight/ Carton
Inner box	305*300*185 MM	1 PC	2.8KG	3.4KG
Outer box	390*315*325 MM	2 PCS	5.6KG	6.8KG

Tolerance of Carton Size: ±15 MM, Tolerance of Weight: ±10%.

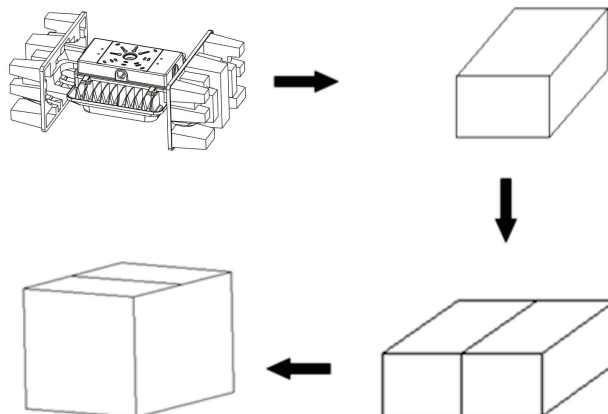

## LIGHT DISTRIBUTION TESTING PARAMETERS

### Luminaire Property

Luminaire Manufacturer:  
 Luminaire Category:  
 Lamp Catalog:  
 Number of Lamps:  
 Luminous Length (mm):  
 Luminous Height (mm):  
 Current: 0.847 A  
 Power Factor: 0.995

Luminaire Description:  
 Lamp Description:  
 Lumens per Lamp:  
 Luminous Width (mm):  
 Voltage: 120.0 V  
 Power: 100.97 W

### Photometric Results

CIE Class: Direct  
 Measurement Flux: 13312.3 lm  
 Downward Ratio: 96%  
 Field Angle(C0/C180,C90/C270,C45/C225,C135/315): 173.7, 173.5, 172.7, 173.1  
 Beam Angle(C0/C180,C90/C270,C45/C225,C135/315): 148.1, 146.0, 138.8, 138.6  
 Luminaire Efficacy Rating (LER): 131.89  
 Max. Intensity: 3525.98 cd  
 S/MH(C0/C180): 2.24

Total Rated Lamp Lumens: 13312.3 lm  
 Efficiency: 100%  
 Upward Ratio: 4%  
 C0r0 Intensity: 1841.35 cd  
 Pos of Max. Intensity: H45 V56  
 S/MH(C90/C270): 2.19

Luminous Intensity Distribution Curve

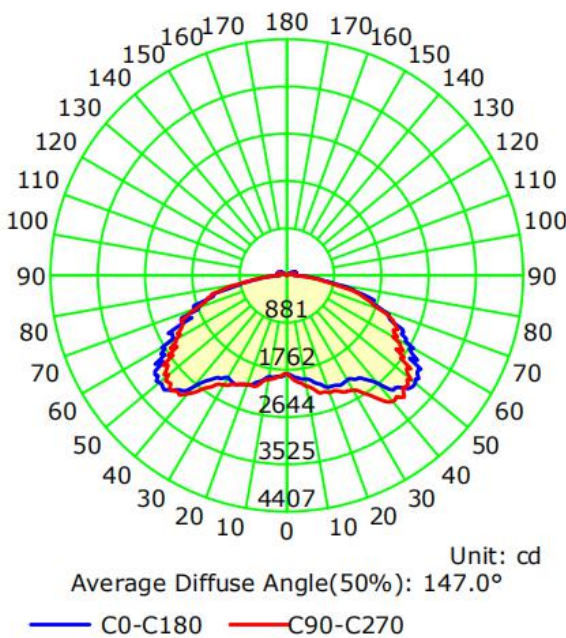

The Average Illuminance Effective Figure

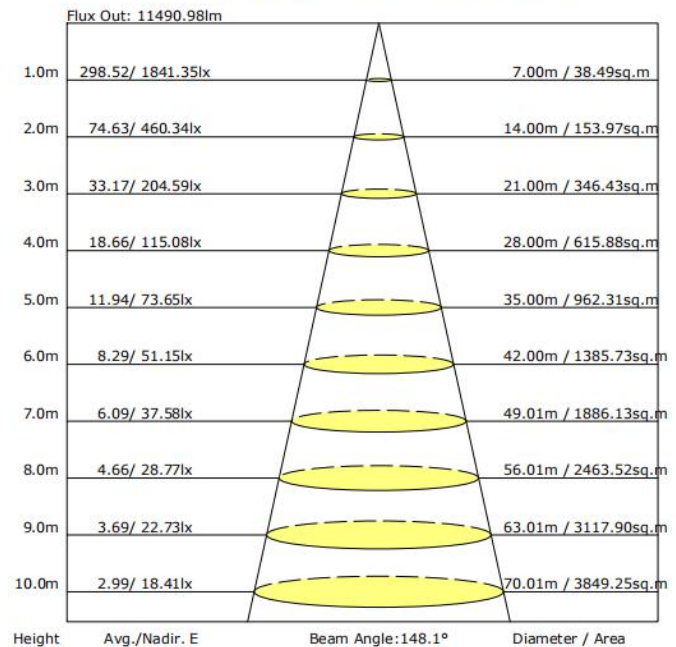

### NOTICE FOR USER

- Please turn off power before install or change assembly parts.
- The input voltage and lamps should be matched, after connecting the power line, Please make sure the wiring section is insulated.
- No-professionals, must not install and disassemble the lamps.

### TROUBLE SHOOTINGS

Troubles	Check points
Flickering of the light	Turn off the power and turn on again in 3 minutes. If same phenomena occur, then call agencies.
Out of working	Please check the connection.